

**ELECTRONICS AND TELECOMMUNICATION
ENGINEERING****Paper I**

Time Allowed : Three Hours

Maximum Marks : 300

QUESTION PAPER SPECIFIC INSTRUCTIONS

Please read each of the following instructions carefully before attempting questions.

There are **EIGHT** questions divided in **TWO** Sections.

Candidate has to attempt **FIVE** questions in all.

Questions No. **1** and **5** are **compulsory** and out of the remaining, **THREE** are to be attempted choosing at least **ONE** question from each Section.

The number of marks carried by a question/part is indicated against it.

Wherever any assumptions are made for answering a question, they must be clearly indicated.

Diagrams/Figures, wherever required, shall be drawn in the space provided for answering the question itself.

Unless otherwise mentioned, symbols and notations carry their usual standard meanings.

Attempts of questions shall be counted in sequential order. Unless struck off, attempt of a question shall be counted even if attempted partly.

Any page or portion of the page left blank in the Question-cum-Answer Booklet must be clearly struck off.

Answers must be written in **ENGLISH** only.

Values of constants which may be required :

Electron charge	= -1.6×10^{-19} Coulomb
Free space permeability	= $4\pi \times 10^{-7}$ Henry/m
Free space permittivity	= $(1/36\pi) \times 10^{-9}$ Farad/m
Velocity of light in free space	= 3×10^8 m/sec
Boltzmann constant	= 1.38×10^{-23} J/K
Planck's constant	= 6.626×10^{-34} J-s

SECTION 'A'

- 1.(a) The transistor in the figure below has maximum ratings of $P_{D(max)} = 500 \text{ mW}$, $V_{CE(max)} = 15 \text{ V}$ and $I_{C(max)} = 100 \text{ mA}$. Determine the maximum value of V_{CC} which would not exceed the device ratings. Take $V_{BE} = 0.7 \text{ V}$. 10

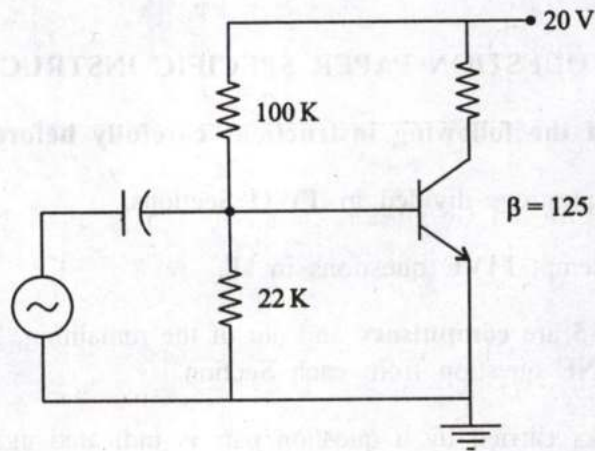

- 1.(b) Determine the output waveforms for the circuit given below by showing the necessary analysis. Differentiate between the operations of shunt clippers and series clippers. 10

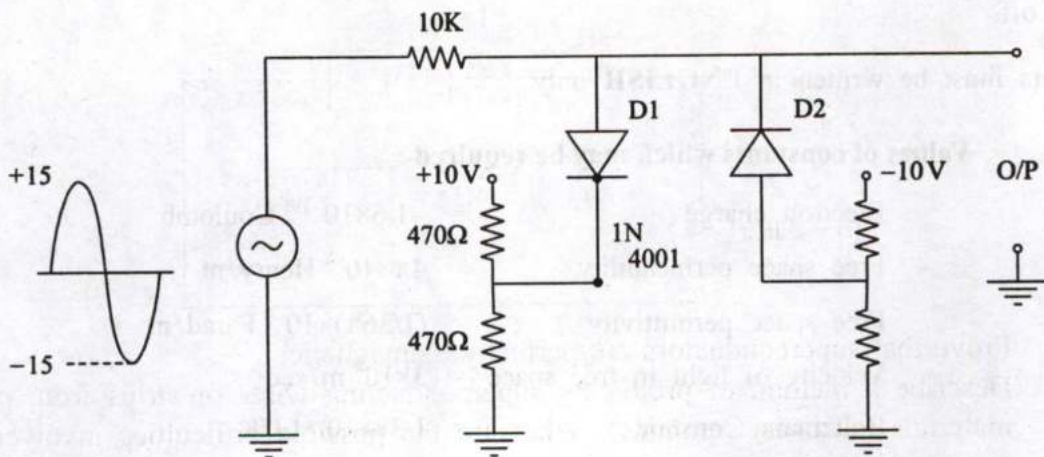

- 1.(c) For the network shown, determine the current through the branch AB , using nodal analysis. 20

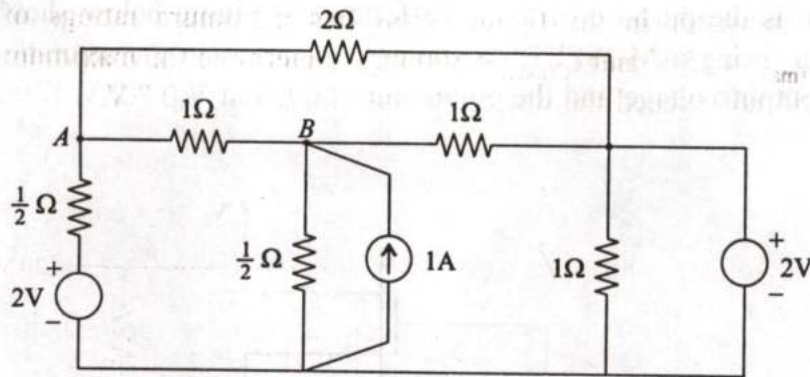

- 1.(d)(i) The concentration of silicon in an iron-silicon alloy is 0.25 wt%. What is the concentration in kilograms of silicon per cubic metre of alloy? [Assume densities of Si and iron as 2.33 and 7.87 gm/cm³ respectively.] 5
- 1.(d)(ii) Molybdenum has the BCC crystal structure, has a density of 10.22 g cm⁻³ and an atomic mass of 95.94 g mol⁻¹. What is the atomic concentration, lattice parameter a , and atomic radius of molybdenum? 5
- 1.(e) Describe the events that occur during sintering. Should green compacts be brought up to the sintering temperature slowly or rapidly? Comment. 10
- 2.(a)(i) Write the circuit schematics, transfer characteristics and contrast the performances of logic inverters based on BJT, CMOS and NMOS devices. 12
- 2.(a)(ii) Show how resistors and capacitors are fabricated in Integrated circuits, with the help of necessary illustrations. 8
- 2.(b) Determine the value of Z_L for maximum power transfer in Z_L , in the given network and hence, find the value of this power. 20

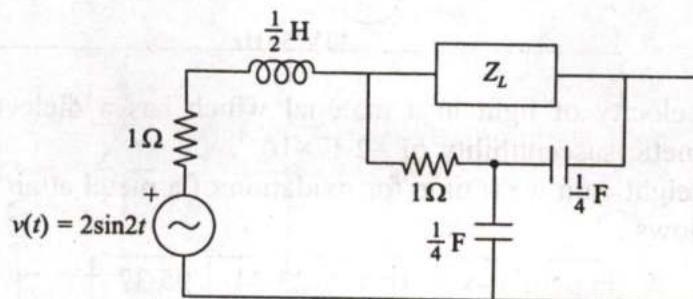

- 2.(c)(i) Prove that superconductors are perfectly diamagnetic. 8
- 2.(c)(ii) Describe a method of producing superconducting wires or strips from powdered materials (such as Ceramics). What are the possible difficulties involved in this process? 12

- 3.(a)(i) What are dependent sources ? Give the model of a voltage controlled current source (VCCS) and determine the expressions for current gain, voltage gain and power gain. 10
- 3.(a)(ii) What is the purpose of a source follower ? Figure below shows a source follower circuit using a MOSFET. Assuming it operates in the saturation region, determine the output voltage and the output current, given $V_{IN} = 2\text{ V}$, $K = 2\text{ mA/V}^2$, $V_T = 1\text{ V}$. 10

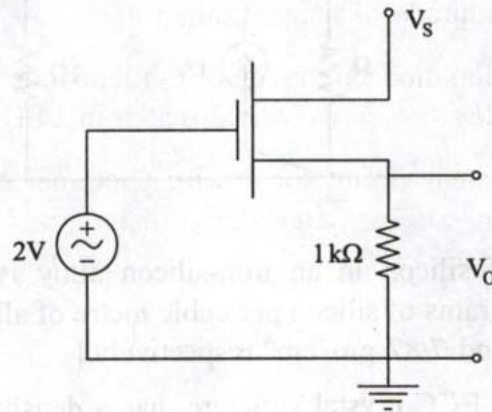

- 3.(b) For the circuit shown in figure, calculate (i) the total impedance, (ii) the total current, (iii) the power factor, (iv) the total apparent power, (v) the active power, and (vi) reactive power. 20

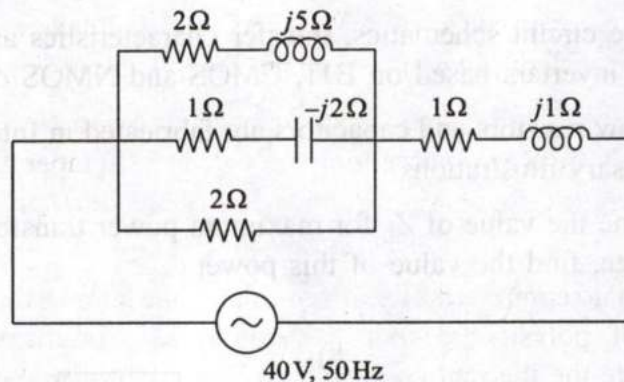

- 3.(c)(i) Find out the velocity of light in a material which has a dielectric constant ϵ_r of 5.5 and a magnetic susceptibility of -2.17×10^{-5} . 5
- 3.(c)(ii) The data for weight gain w.r.t. time for oxidation of a metal at an elevated temperature are as follows :

W (mg/cm^3) \rightarrow	1.54	23.24	95.37
Time (min) \rightarrow	10	150	620

- Determine whether the oxidation kinetics obey a logarithmic, linear or parabolic rate expression.
- Also calculate W after a time of 1200 min. 5

- 3.(c)(iii) Consider a current of 10 A flowing through a coil of wire. The coil of wire 0.20 m long has 200 turns.
1. What is the magnitude of magnetic field strength H ?
 2. Calculate the flux density B if the coil is in a vacuum.
 3. Calculate the flux density inside a bar of titanium (susceptibility = 1.81×10^{-4}) that is positioned within the coil.
 4. Calculate the magnitude of magnetisation M . 10
- 4.(a)(i) Both LED and Junction diode are made of $p-n$ junctions. Contrast their construction and working. How does a Laser diode differ from LED? 8
- 4.(a)(ii) By writing an equivalent circuit for a $p-i-n$ photo-detector, obtain the relation for the SNR of an optical receiver, considering the various noise sources. 12
- 4.(b) A 75 KVA, 230 V/115 V, 60 Hz transformer was tested with the following results :
 Short circuit test : 9.5 V, 326 A, 1200 W
 Open circuit test : 115 V, 16.3 A, 750 W
- Determine the (i) equivalent impedance in high-voltage terms, (ii) equivalent impedance in per unit, (iii) voltage regulation at rated load and 0.8 power factor lagging, (iv) efficiency at rated load and 0.8 power factor lagging and also at $\frac{1}{2}$ load and unity power factor. 20
- 4.(c)(i) 1. "The ferroelectric behaviour of BaTiO_3 ceases above its ferroelectric Curie temperature." Explain whether this statement is correct, giving reasons.
 2. Differentiate between Curie temperature and Neel temperature, and also draw a graph between susceptibility (χ) and Temperature (K) to demonstrate this difference for Paramagnetic, Ferromagnetic and Antiferromagnetic materials. 5+5
- 4.(c)(ii) A laminate composed of 0.1 mm thick aluminium sandwiched around a 20 mm thick layer of polystyrene foam (styrofoam) is produced as an insulation material. Calculate the thermal conductivity of the laminate parallel and perpendicular to the layers. The thermal conductivity of aluminium is $238.6 \text{ W m}^{-1} \text{ K}^{-1}$ and that of foam is $0.032 \text{ W m}^{-1} \text{ K}^{-1}$. 10

SECTION 'B'

- 5.(a) What are the objectives of a Data Acquisition System (DAS)? Write the block schematic of a multichannel DAS, handling analog signals as input. 10
- 5.(b) A wattmeter has a current coil of 0.1Ω resistance and a pressure coil of $6.5 \text{ k}\Omega$ resistance. Calculate the percentage errors, due to resistance only with each of the two methods of connection shown in figure, when reading the input to an apparatus which takes :

- (i) 12 A at 250 V with unity power factor and
(ii) 12 A at 250 V and 0.4 power factor.

10

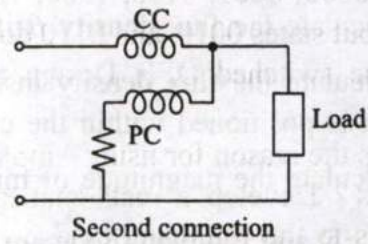
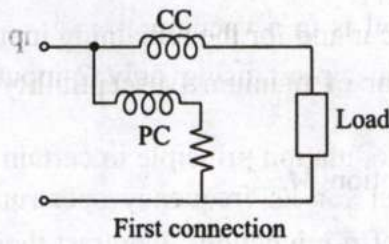

- 5.(c) The switch S shown in figure is initially at position '2' and is moved to position '1' at $t = 0$ second. Then, at $t = 2$ seconds the switch S is again moved to position '2'. Find the voltage across the resistor R_2 for $t > 2$ seconds. 20

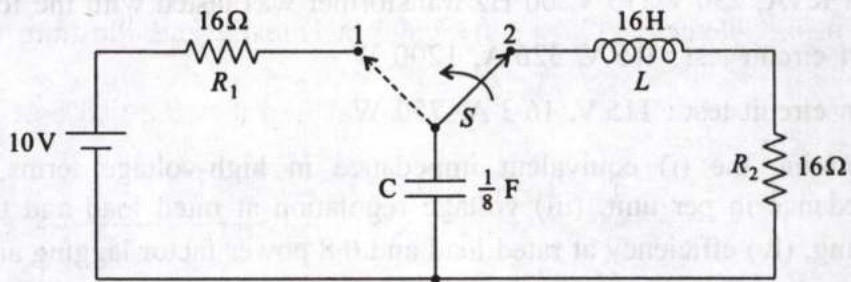

- 5.(d) For a two-stage, capacitively coupled amplifier as shown below, find the following :
(i) Voltage gain of each stage
(ii) Overall voltage gain
(iii) Express the gains found in (a) & (b) in dB. 10

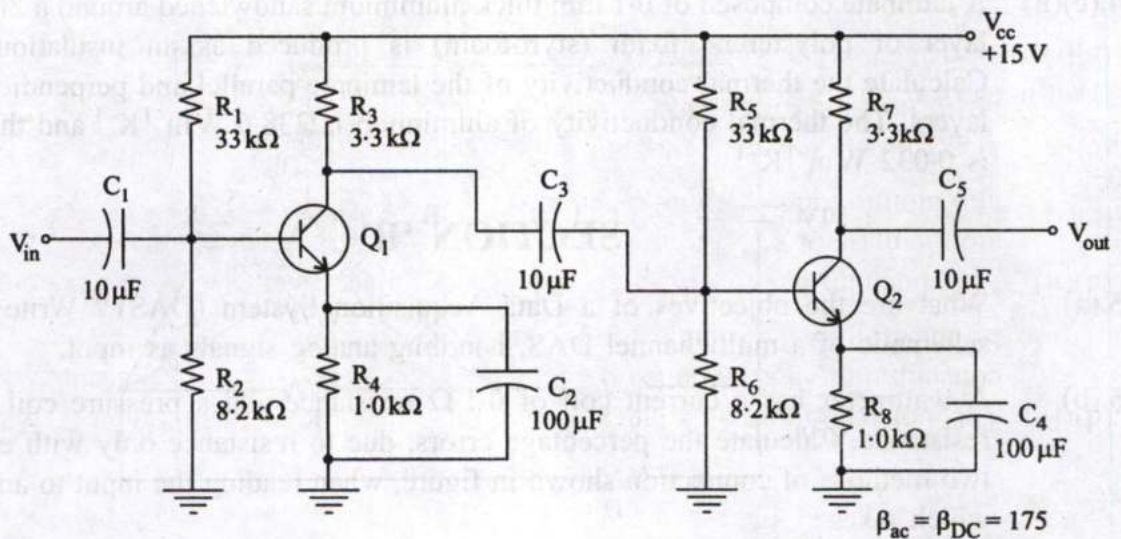

- 5.(e) The operation of a relay switch for a particular application is controlled by the output Y of a logic circuit which is having four inputs A, B, C, D . The relay switch must be switched ON when Y is '1' for the following inputs ($ABCD$):

0000, 0001, 0100, 1000, 1001, 1011.

The input states 0010, and 0110 do not occur and for the remaining input states, relay must be switched OFF. Design the logic circuit using only 2-input NOR gates.

10

- 6.(a)(i) What is the reason for using Amplitude modulation principle in certain measurement systems? Develop a mathematical model for its frequency spectrum. Apply this analysis to the following cases:

- Vibration and noise of shafts with gears (20 teeth gear running at 4000 Hz).
- Recording very small voltages of a strain gauge and amplifying its output, assuming strain gauge bridge is excited by an ac signal of amplitude 5 V and a frequency of 3000 Hz.

12

- 6.(a)(ii) Which technique would you employ for transmitting slow changing low bandwidth data using telemetry? Write the block schematic and illustrate the principle of working.

8

- 6.(b)(i) Determine the transmission parameters for the following two port network shown.

12

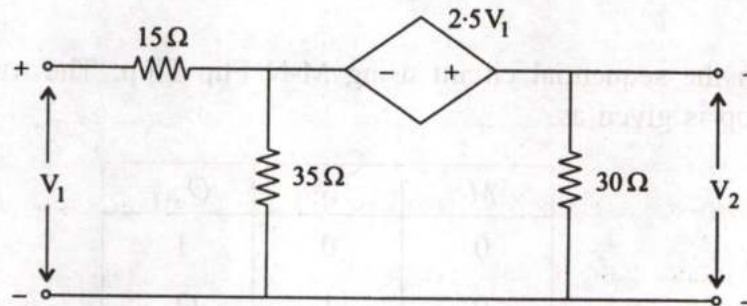

- 6.(b)(ii) Using delta-to-star transformation, determine the current I in the circuit shown in figure when the value of the resistor $R = 15 \Omega$.

8

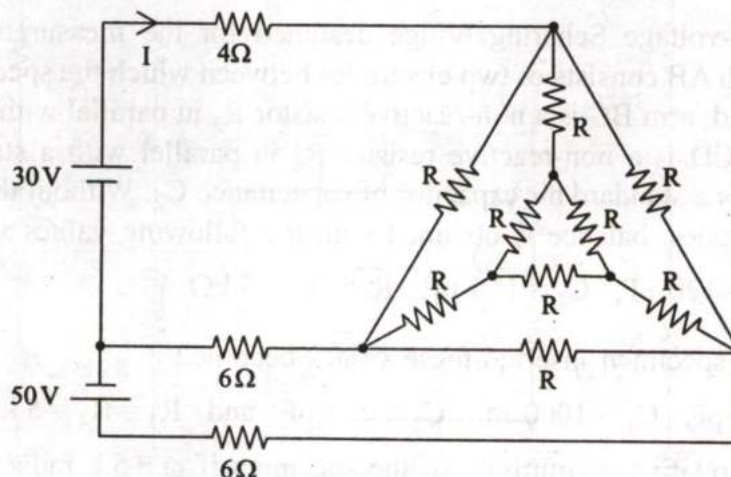

6.(c) A sequential circuit has one input and one output. The state diagram of the sequential circuit is given.

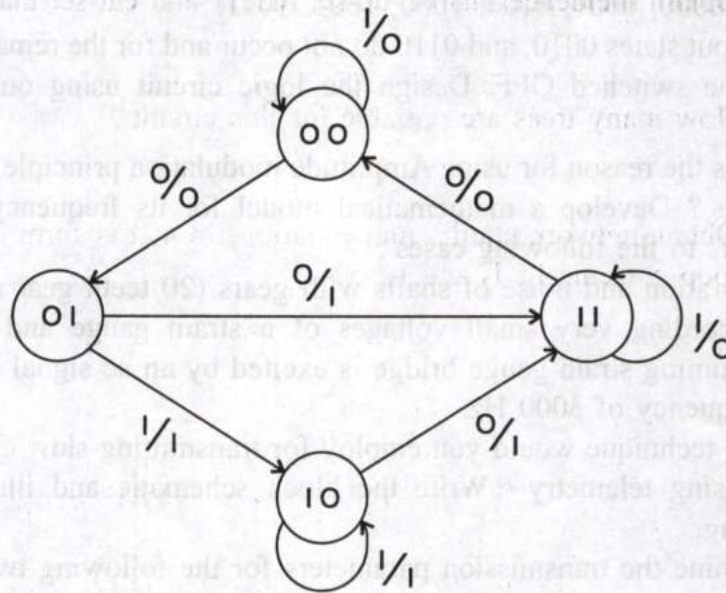

Design the sequential circuit using M-N Flip Flop. The truth table for the M-N flip flop is given as

M	N	Q_{n+1}
0	0	1
0	1	\bar{Q}_n
1	0	Q_n
1	1	0

20

7.(a) In a low-voltage Schering bridge designed for the measurement of permittivity, the branch AB consists of two electrodes between which the specimen under test may be inserted; arm BC is a non-reactive resistor R_3 in parallel with a standard capacitor C_3 ; arm CD is a non-reactive resistor R_4 in parallel with a standard capacitor C_4 ; arm DA is a standard air capacitor of capacitance C_2 . Without the specimen between the electrodes, balance is obtained with the following values :

$$C_3 = C_4 = 120 \text{ pF}, \quad C_2 = 150 \text{ pF}, \quad R_3 = R_4 = 5 \text{ k}\Omega.$$

With the specimen inserted these values become :

$$C_3 = 200 \text{ pF}, \quad C_4 = 1000 \text{ pF}, \quad C_2 = 900 \text{ pF} \quad \text{and} \quad R_3 = R_4 = 5 \text{ k}\Omega.$$

Find the relative permittivity of the specimen if $\omega = 5 \text{ k rad/s}$.

20

7.(b) For the circuit diagram shown below, draw the graph and

(i) Obtain incidence matrix, tie-set matrix and cut-set matrix.

(ii) How many trees are possible for this circuit ?

(iii) Obtain network equilibrium equations in matrix form using KVL and find the loop currents I_1 , I_2 and I_3 . 20

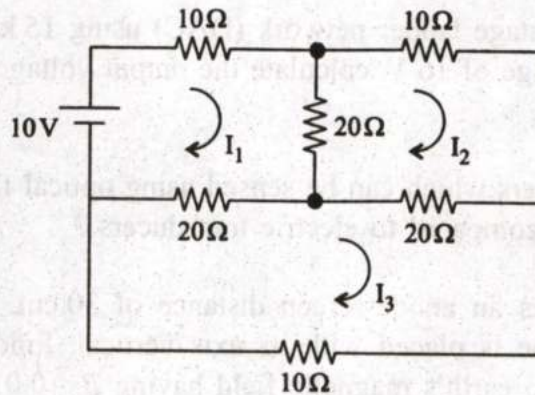

7.(c)(i) The circuit below represents a filter between the input current i_1 and output voltage v_o . Assume the opamp is ideal. Identify the type of filter (low pass/band pass/high pass/band stop). Provide justification for your answer. 5

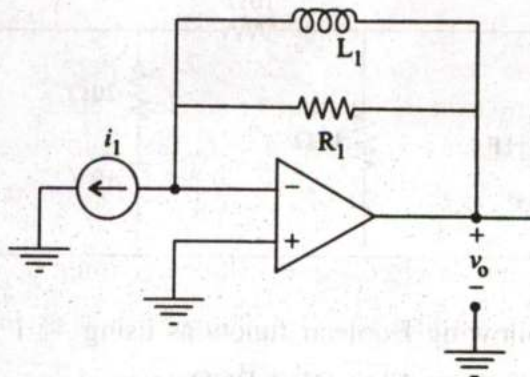

- 7.(c)(ii) In the wave-shaping circuit shown, the switch is initially in position 1. The switch is thrown into position 2, and held there for 10 ms, then back to position 1 for 10 ms, and so on. Sketch the resulting output waveform if its initial value is 0V. The saturated output levels of the opamp are ± 12 V. 10

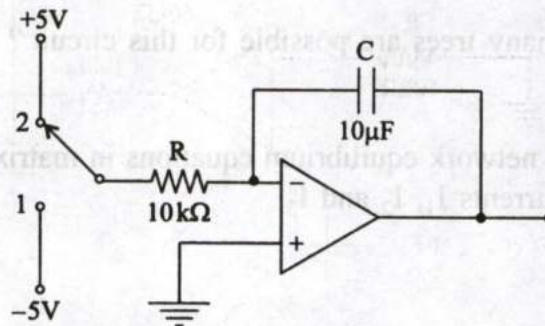

- 7.(c)(iii) Sketch a five-stage ladder network (DAC) using $15\text{ k}\Omega$ and $30\text{ k}\Omega$ resistors. For a reference voltage of 16 V, calculate the output voltage for an input of 11010 to the circuit. 5
- 8.(a)(i) List 6 parameters which can be sensed using optical fibres. How can this sensor be advantageous compared to electric transducers? 10
- 8.(a)(ii) A CR tube has an anode-screen distance of 30 cm. The accelerating potential is 1 KV. The tube is placed with its axis vertical. Find the maximum deflection of the spot due to earth's magnetic field having $B = 0.018 \times 10^{-3}\text{ wb/m}^2$. 10
- 8.(b)(i) The zeros of the admittance function of a parallel RLC circuit are located at $-6+j8$ and $-6-j8$. If the value of the resistance R is $25\ \Omega$, find the quality factor of the circuit. 12
- 8.(b)(ii) Obtain the state equations for the circuit shown below by considering $v_c(t)$ and $i_L(t)$ as state variables. 8

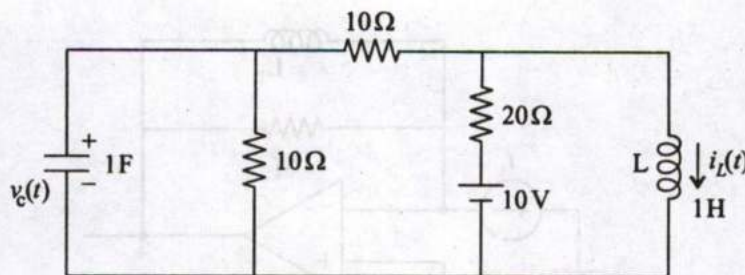

- 8.(c)(i) Realize the following Boolean functions using 4 : 1 multiplexer :

$$Y(A, B, C, D) = \bar{A}\bar{D} + B\bar{D} + \bar{B}CD$$

8

- 8.(c)(ii) 1. For the circuit shown, sketch and label the transfer characteristic $v_o - v_i$. The diodes are assumed to have a constant 0.7 V drop when conducting, and the opamp saturates at ± 12 V. What is the maximum diode current? 7

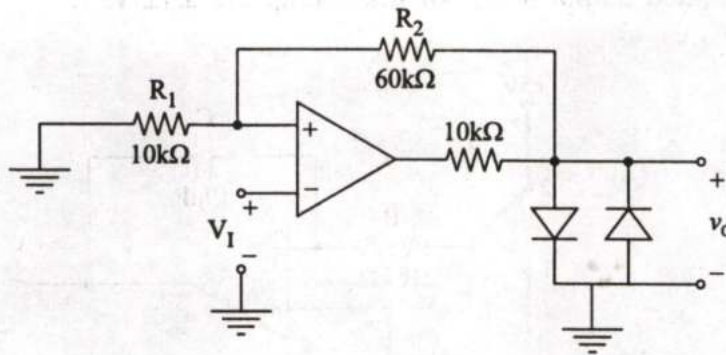

2. In the above circuit, if R_1 is open circuit and R_2 is short-circuit, redraw the characteristics. 5

10. (a) For the circuit shown, sketch and label the transfer characteristic v_o/v_i . The diodes are assumed to have a constant 0.7 V drop when conducting, and the op-amp saturates at ± 12 V. What is the maximum diode current?

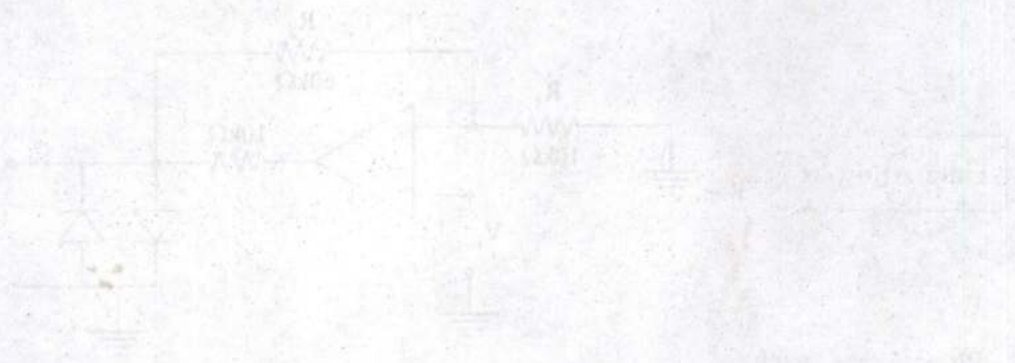

11. In the above circuit, if R_1 is open circuit and R_2 is short circuit, sketch the characteristic.