

CIVIL ENGINEERING

Paper – I

Time Allowed : **Three Hours**

Maximum Marks : **300**

Question Paper Specific Instructions

Please read each of the following instructions carefully before attempting questions :

*There are **EIGHT** questions divided in **TWO** sections.*

*Candidate has to attempt **FIVE** questions in all.*

*Questions No. **1** and **5** are **compulsory** and out of the remaining, any **THREE** are to be attempted choosing at least **ONE** question from each section.*

The number of marks carried by a question / part is indicated against it.

Wherever any assumptions are made for answering a question, they must be clearly indicated.

Diagrams / Figures, wherever required, shall be drawn in the space provided for answering the question itself.

Unless otherwise mentioned, symbols and notations have their usual standard meanings.

Attempts of questions shall be counted in sequential order. Unless struck off, attempt of a question shall be counted even if attempted partly.

Any page or portion of the page left blank in the Question-cum-Answer Booklet (QCA) must be clearly struck off.

*Answers must be written in **ENGLISH** only.*

SECTION A

- Q1.** (a) (i) What are the functions of cement mortar in brick masonry work? 6
 (ii) What are the purposes of making frog in bricks during moulding? 6
 Explain with the help of neat sketches.
- (b) A rectangular plate in biaxial stress is subjected to normal stress $\sigma_x = 65$ MPa and $\sigma_y = -20$ MPa. The plate ($b \times h \times t$) has dimensions $200 \times 300 \times 15$ and is made of aluminium with $E = 75$ GPa and $\nu = 0.33$. All dimensions are in mm. Determine
- (i) the maximum in-plane shear strain (γ_{\max}) in the plate,
 - (ii) the change in the thickness of the plate (Δt), and
 - (iii) the change in volume of the plate (ΔV).

12

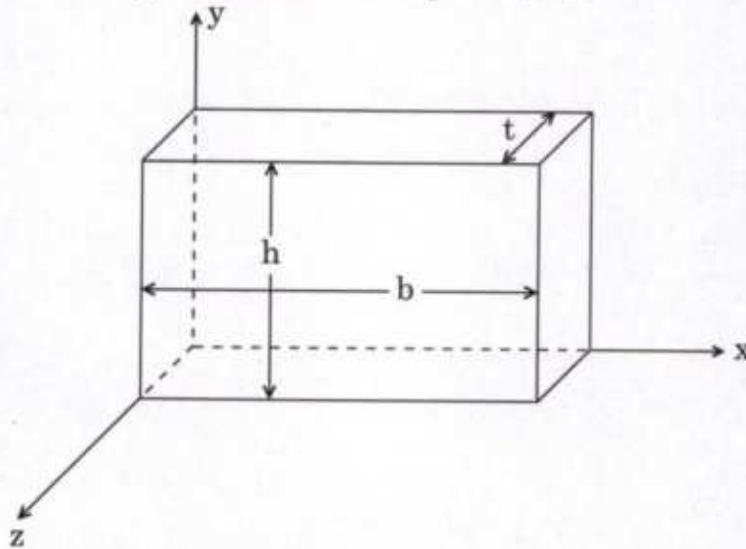

- (c) The electric motor exerts a torque of 800 N on the steel shaft ABCD when it is rotating at constant speed. Design specifications require that the diameter of the shaft be uniform from A to D and that the angle of twist between A and D not exceed 1.5° . Knowing that $\tau_{\max} \leq 60$ MPa and $G = 77$ GPa, determine the diameter of the shaft that may be used.

12

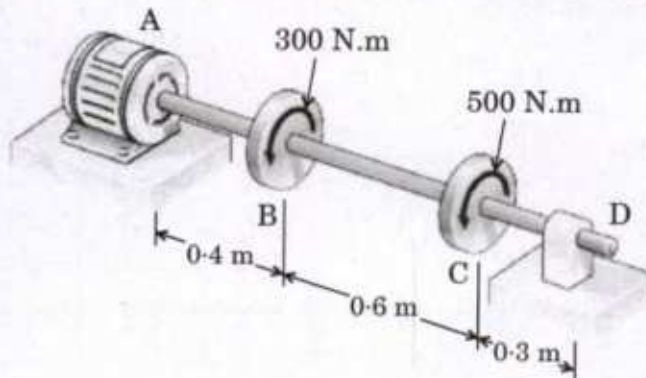

- (d) Analyse the propped cantilever beam shown in the figure. During loading the prop B sinks by 6 mm. $E = 2 \times 10^5$ MPa, $I = 86.04 \times 10^6$ mm⁴. Draw Shear force and Bending moment diagrams. Find the Maximum BM value and its location from either of the supports. 12

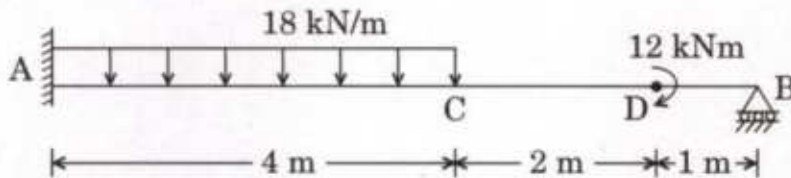

- (e) A simply supported rectangular beam (cross-section 300 mm × 400 mm) with effective span of 6 metres is carrying the following characteristic load :
- (i) Characteristic Dead Load (including self-weight) = 15 kN/m
 - (ii) Characteristic Imposed Load (not fixed) = 10 kN/m
 - (iii) Characteristic Equivalent Wind Load (acting downward) = 5 kN/m

Calculate the Design Bending Moment and Design Shear Force for most critical load combination for limit state of collapse and limit state of serviceability. 12

Partial Safety Factor (γ_f) for loads						
Load Combination	Limit State of Collapse			Limit State of Serviceability		
	Dead Load	Imposed Load	Wind Load	Dead Load	Imposed Load	Wind Load
Dead Load + Imposed Load	1.5	1.5	–	1.0	1.0	–
Dead Load + Wind Load	0.9	–	1.5	1.0	–	1.0
Dead Load + Imposed Load + Wind Load	1.2	1.2	1.2	1.0	0.8	0.8

- Q2.** (a) A steel bar AB of length 3.5 m and diameter 25 mm is connected by four inextensible cables of length 2.5 m each, forming a rhombus with AB as diagonal. A 100 kN force acts at the points C and D. Determine the decrease in length of the member AB and increase in the length between points C and D. Take modulus of steel as 201 GPa. 20

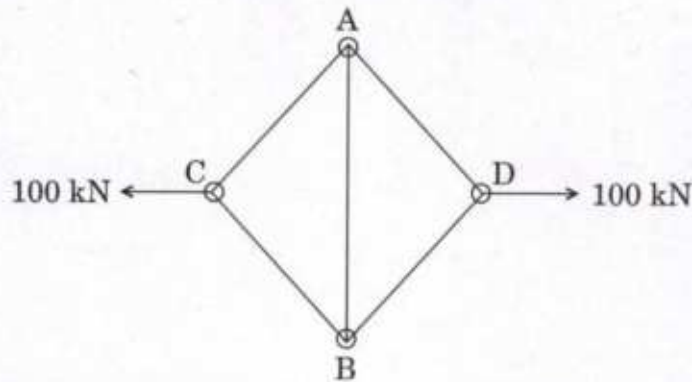

- (b) Determine the maximum load P the joint can carry if bolts of M 20, grade 4.6 are used. 20

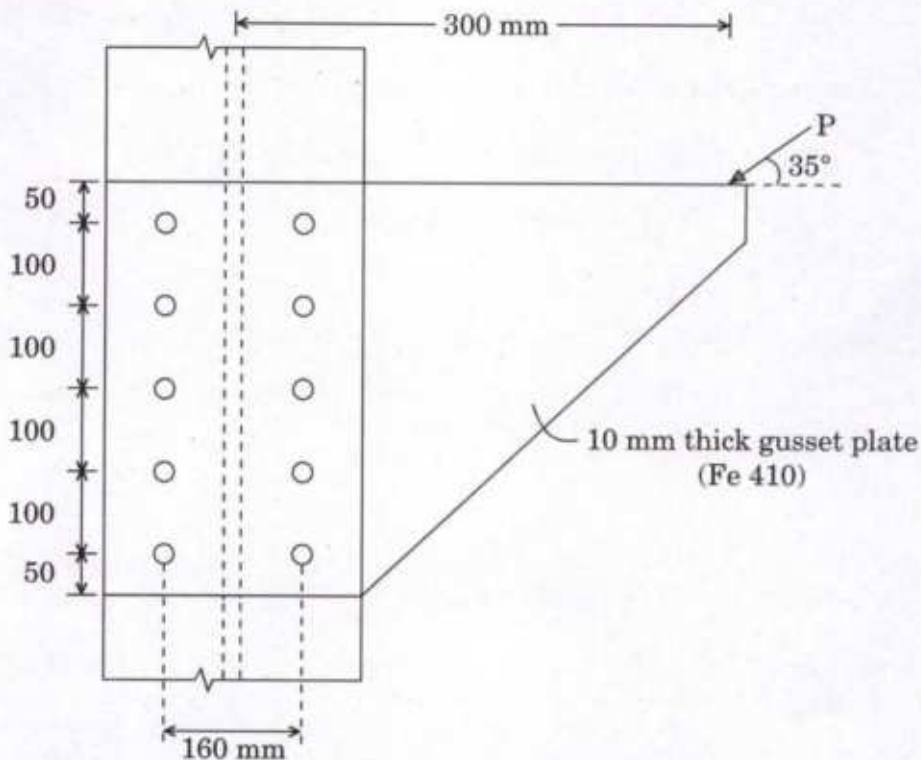

$$\text{Design shear strength of bolt } V_{nsb} = \frac{f_{ub}}{\sqrt{3}} \cdot \frac{A_{nb}}{\gamma_{mb}}$$

$$\text{Bearing strength of bolt} = \frac{1}{\gamma_{mb}} 2.5 k_b \cdot d \cdot t \cdot f_u$$

$$\text{where } k_b = \text{Least of } \left[\frac{e}{3d_o}, \left(\frac{p}{3d_o} - 0.25 \right), \frac{f_{ub}}{f_u}, 1.0 \right]$$

- (c) (i) How do super plasticizers increase the mobility and make the cement concrete flow ? What is the advantage of using fly ash in concrete for massive dam construction work ? 10
- (ii) What are the disadvantages of destructive methods of testing concrete and advantages of non-destructive testing of concrete ? 10

- Q3. (a) A point on a thin plate is subjected to the two successive states of stress as shown in the figure below. Using Mohr's circle method, determine
- (i) the resultant state of stress represented on the element oriented as shown on the right.
- (ii) the principal stresses and principal planes caused by the superposition of these two stress states. 20

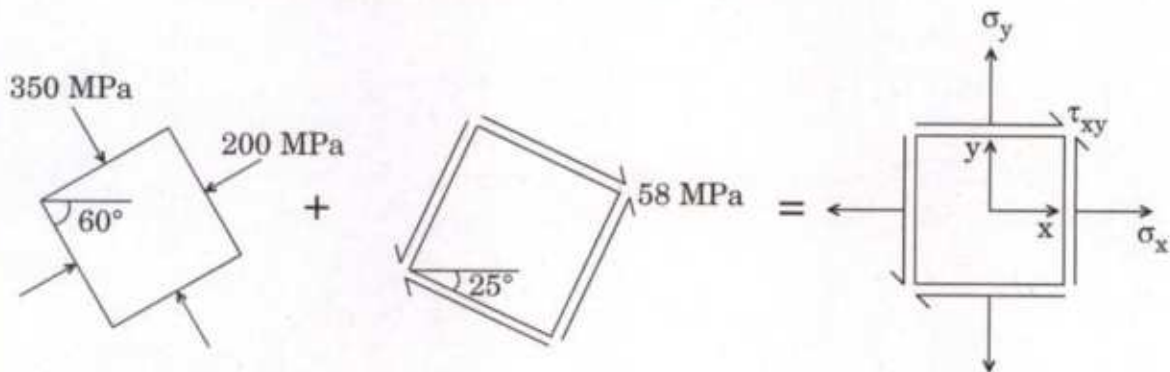

- (b) A solid RCC slab is having effective span of $L_x = 3.0$ m and $L_y = 4.5$ m. Position of slab S-1 is shown in the figure below.

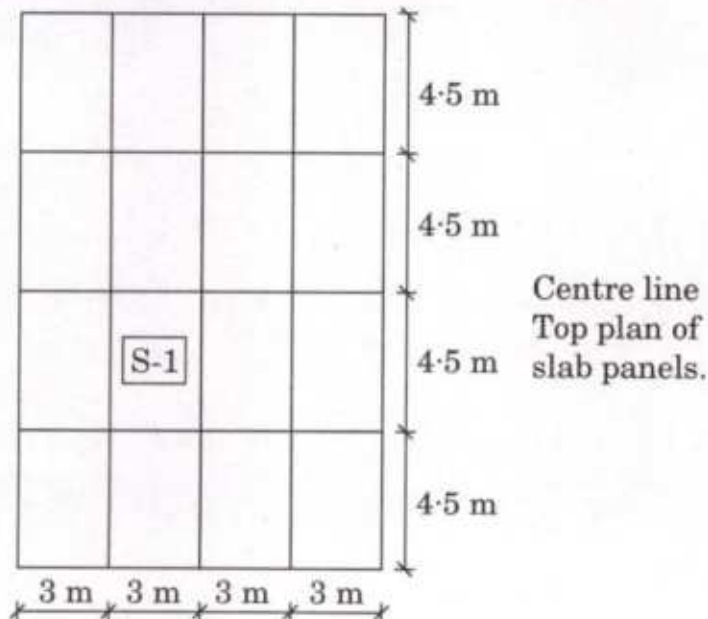

Slab carrying total design load of 20 kN/m^2 . In slab S-1, calculate and provide the spacing of all main reinforcement only, by limit state method of design, for 8 mm diameter high strength deformed bars. Check these spacings must not exceed the standard guidelines of IS 456 : 2000. 20

Effective thickness of slab = 120 mm

Grade of concrete M 20

Grade of reinforcement Fe 415

$\frac{M}{bd^2}$	0.30	0.40	0.512	0.60	0.65	0.662
p_t	0.085	0.114	0.143	0.172	0.187	0.203

p_t is the percentage of reinforcement.

IS 456 : 2000

Table : Bending Moment Coefficients for Rectangular Panels Supported on Four Sides with Provision for Torsion at Corners
(Clauses D-1.1 and 24.4.1)

Case No.	Type of Panel and Moments Considered	Short Span Coefficients α_x (Values of l_y/l_x)								Long Span Coefficients α_y for All Values of l_y/l_x
		1.0	1.1	1.2	1.3	1.4	1.5	1.75	2.0	
(1)	(2)	(3)	(4)	(5)	(6)	(7)	(8)	(9)	(10)	(11)
1	<i>Interior Panels :</i> Negative moment at continuous edge	0.032	0.037	0.043	0.047	0.051	0.053	0.060	0.065	0.032
	Positive moment at mid-span	0.024	0.028	0.032	0.036	0.039	0.041	0.045	0.049	0.024
9	<i>Four Edges Discontinuous :</i> Positive moment at mid-span	0.056	0.064	0.072	0.079	0.085	0.089	0.100	0.107	0.056

- (c) Design Bending moment and Shear force diagram have been given below for a two span continuous beam. Effective span of beam is 6.0 m each. Design a rectangular, singly reinforced RCC beam section at support 'B' only by LSM of design.

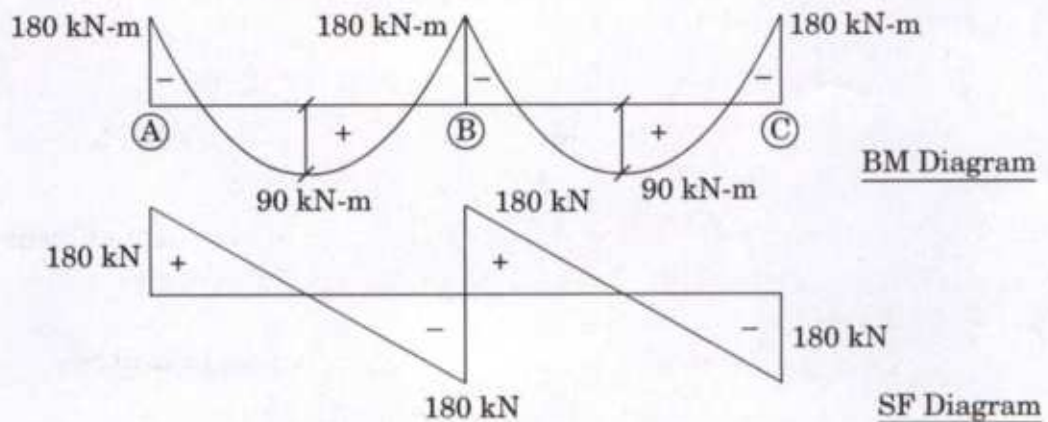

20

The following parameters may be used for design. All notations are as per IS 456 : 2000.

- (1) Grade of concrete M 20
- (2) Grade of reinforcement Fe 415
- (3) Nominal cover to reinforcement – 25 mm
- (4) (Effective depth/width) ratio – 2
- (5) Diameter of flexural bar – 20 mm
- (6) Diameter of shear reinforcement – 8 mm (CS Area 50 mm²)
- (7) Design shear strength of concrete $\tau_c = 0.88 \text{ N/mm}^2$
- (8) Maximum shear stress $\tau_{c \text{ max}} = 2.8 \text{ N/mm}^2$
- (9) Round off effective (calculated) to next higher multiple of 100
- (10) $M_{u, \text{ lim}} / f_{ck} b d^2 = 0.138$

$$(11) \quad (x/d) = 1.2 - \left[(1.2)^2 - \frac{6.68 M_u}{f_{ck} b d^2} \right]^{1/2}$$

$$(12) \quad \text{Lever arm } z = d \left(1 - 0.42 \frac{x}{d} \right)$$

$$(13) \quad A_{st} = \frac{M_u}{0.87 f_y \cdot z}$$

$$(14) \quad V_{us} = \frac{0.87 f_y \cdot A_{sv} \cdot d}{S_v}$$

$$(15) \quad \text{Minimum shear reinforcement} = \frac{A_{sv}}{b \cdot S_v} = \frac{0.40}{0.87 f_y}$$

Check all spacing of reinforcement as per standard guidelines.

- Q4.** (a) (i) Briefly explain the following with the help of neat sketches : 10
- I. Structure of an exogenous tree
 - II. Heart shakes and star shakes defects in timber

- (ii) Determine the proportion of aggregates A (with Fineness Modulus $FM = 7.83$) and B ($FM = 6.81$) required to suitably combine to provide the following grading of such a combination : 10

IS sieve designation (mm)	80 mm	40 mm	20 mm	10 mm	4.75 mm	2.36 mm	1.18 mm	600 μm	300 μm	150 μm
Cumulative percentage retained on each sieve	0	6	45	72	95	100	100	100	100	100

- (b) A T-section beam is constructed by gluing two pieces of wood together as shown in the figure. The maximum stress in the glue joints is to be limited to 2 MPa in tension and the maximum shear stress is to be limited to 1.7 MPa.

- (i) Determine the stress components on element at point 'P'. Point 'P' is located at glued joint.
- (ii) Determine principal stresses at point 'P'.
- (iii) Show these stresses on properly oriented 2-D element.
- (iv) Determine the maximum value for load w .

20

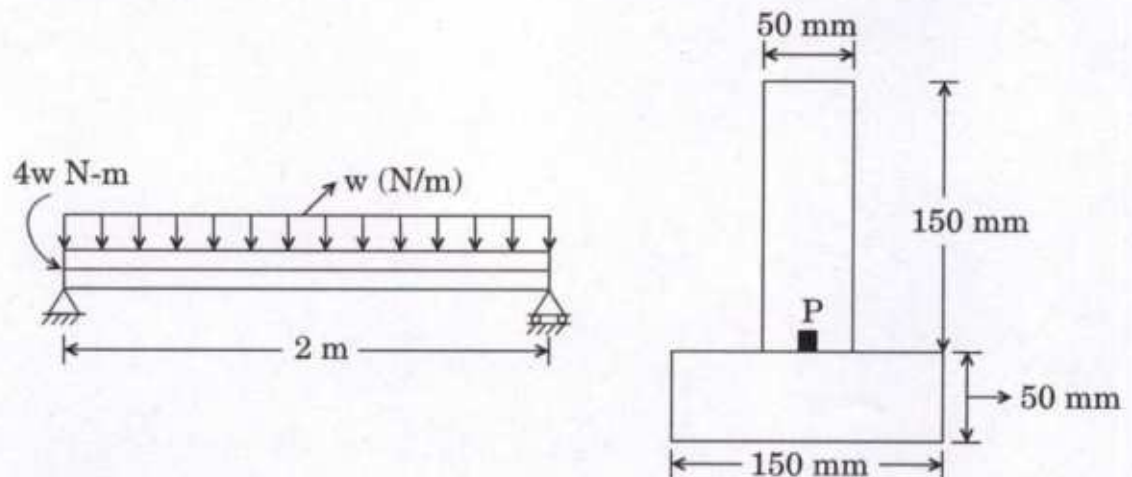

Sign convention for shear force and bending moment are as follows :



- (c) An RCC cantilever retaining wall is to be designed to support the soil as shown below. Design and sketch the *reinforcement* for vertical wall only. Also sketch the position of main reinforcement in Toe and Heel slab. (Do not design Toe and Heel slab). Neglect the effect of passive earth pressure and self-weight of vertical wall. Water table is not affecting the moisture condition of retained soil.

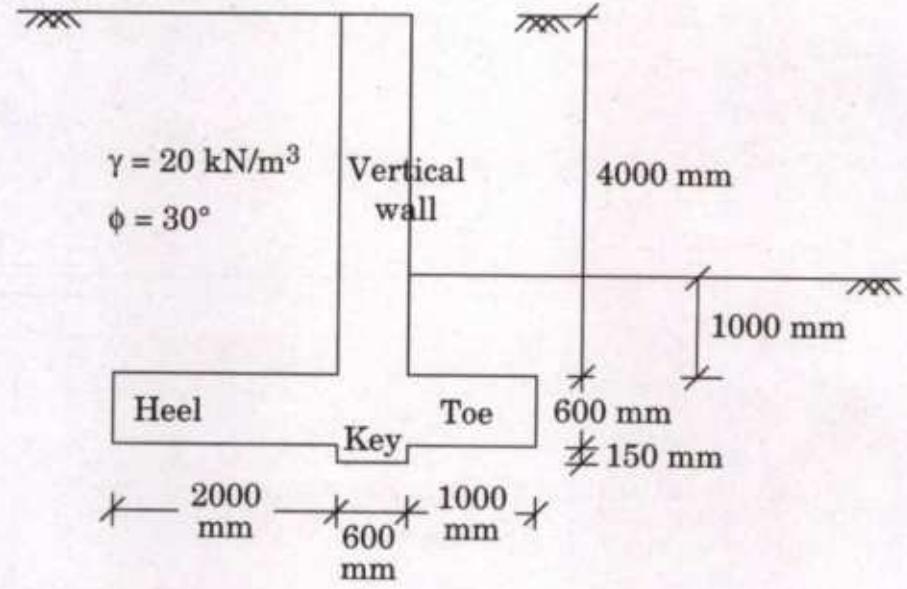

- (1) M 20 grade of concrete
- (2) Fe 415 grade of reinforcement
- (3) Diameter of main and distribution reinforcement : 8 mm
- (4) Minimum effective thickness required : 400 mm
- (5) $K_a = \frac{1 - \sin \phi}{1 + \sin \phi}$

For M 20 and Fe 415

Percentage reinforcement p_t in %

$\frac{M_u}{bd^2}$	0.4	0.5	0.6	0.667
p_t	0.114	0.142	0.172	0.204

Design shear strength of concrete τ_c in N/mm^2

p_t	0.15	0.25	0.5	0.75
τ_c	0.28	0.36	0.48	0.56

SECTION B

- Q5.** (a) A rectangular prestress concrete beam has a cross-section of 200 mm × 300 mm. Its effective span is 8 metres. This beam is prestressed by a straight cable, 50 mm below the central longitudinal axis. This beam supports an imposed load of 20 kN/m.

Find the magnitude of prestressing force which can balance the stresses due to dead load and imposed load at bottom fibre of mid-span. Unit weight of concrete : 25 kN/m³.

12

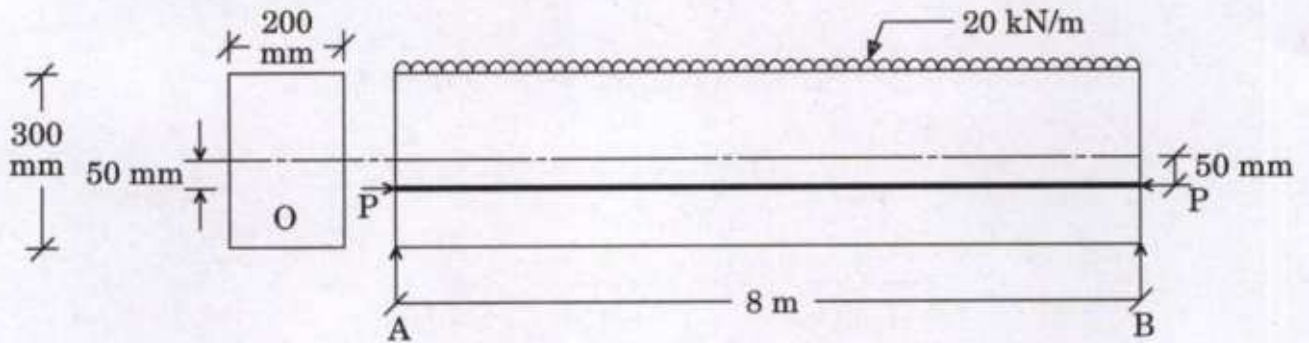

- (b) The compound beam is subjected to a uniform dead load of 1.5 kN/m and a single live load of 10 kN. Determine
- (i) the maximum negative moment created by these loads at 'A', and
 - (ii) maximum positive shear at 'B'.

12

Assume A is a fixed support, B is a pin and C is a roller.

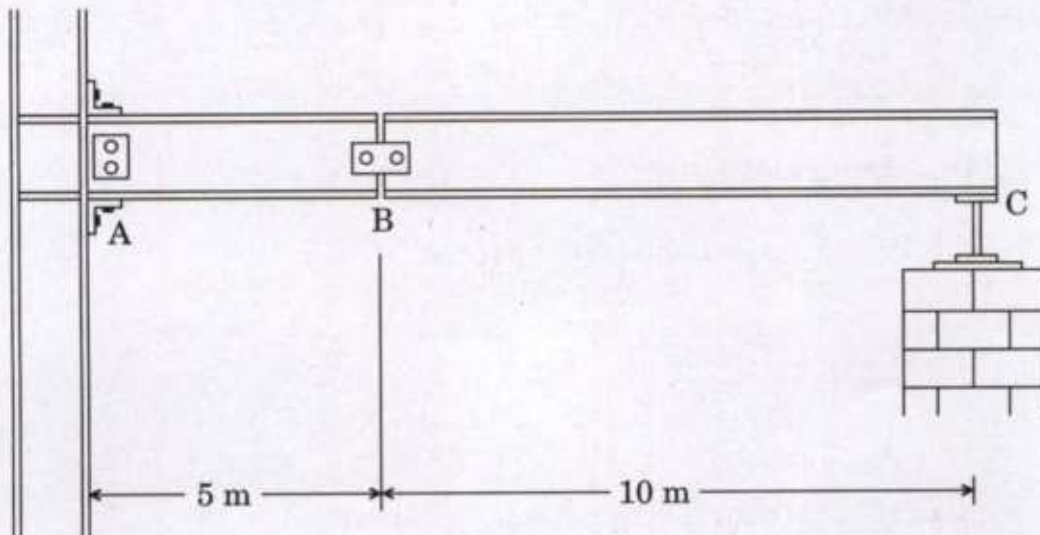

- (c) Derive the expression for displacement of an undamped free vibration of motion for a single degree of freedom system from first principles. Plot the undamped free vibration response.

12

- (d) Calculate the safe load of a compression member made up of a welded box section as shown in the figure. The effective lengths along major axis and minor axis are 5 m and 2 m respectively. The yield stress of the material is 340 MPa.

$\frac{KL}{r}$	Design Compressive Stress f_{cd} (MPa)
20	299
30	278
40	256

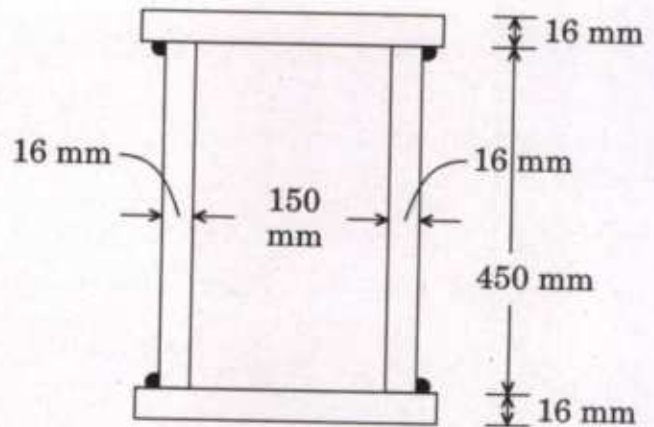

12

- (e) (i) What information is generally needed to be provided in tender documents ?
- (ii) Differentiate between 'Lump sum contract' and 'Unit price contract'.

6

6

- Q6. (a) Design an RCC square column with the following data. Provide the main reinforcement and stirrups. Check the standard guidelines of IS 456 : 2000.

20

- (1) Column size : 500 mm × 500 mm
- (2) Concrete grade M 20
- (3) Steel reinforcement Fe 415
- (4) Design load : 1600 kN
- (5) Design moment $M_{ux} = M_{uy} = 100$ kN
- (6) Eccentricities $e_x = e_y = 20$ mm
- (7) Minimum reinforcement : 1.2%

(8) Check
$$\left[\frac{M_{ux}}{M_{ux1}} \right]^{\alpha_n} + \left[\frac{M_{uy}}{M_{uy1}} \right]^{\alpha_n} \leq 1.0, \text{ where } \alpha_n = \frac{P_u}{P_{uz}}$$

- (9) Diameter of longitudinal reinforcement : 20 mm
- (10) Diameter of lateral ties : 8 mm
- (11) Nominal cover to reinforcement : 40 mm

**COMPRESSION WITH BENDING – Rectangular
Section – Reinforcement Distributed Equally on Four Sides**

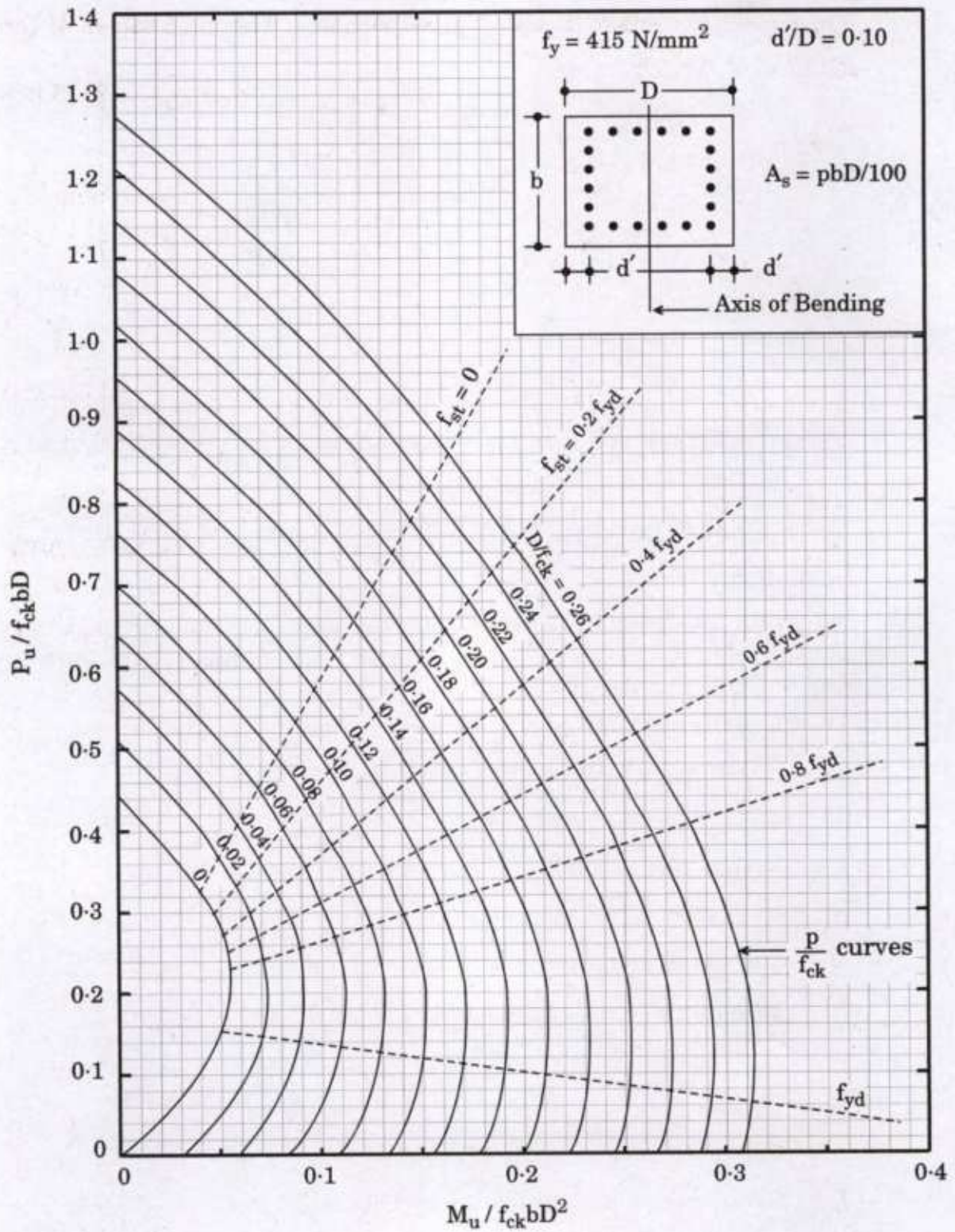

f_y
250
415
500

f_{ck}
15
20
25
30

VALUES OF P_{uz} for COMPRESSION MEMBERS

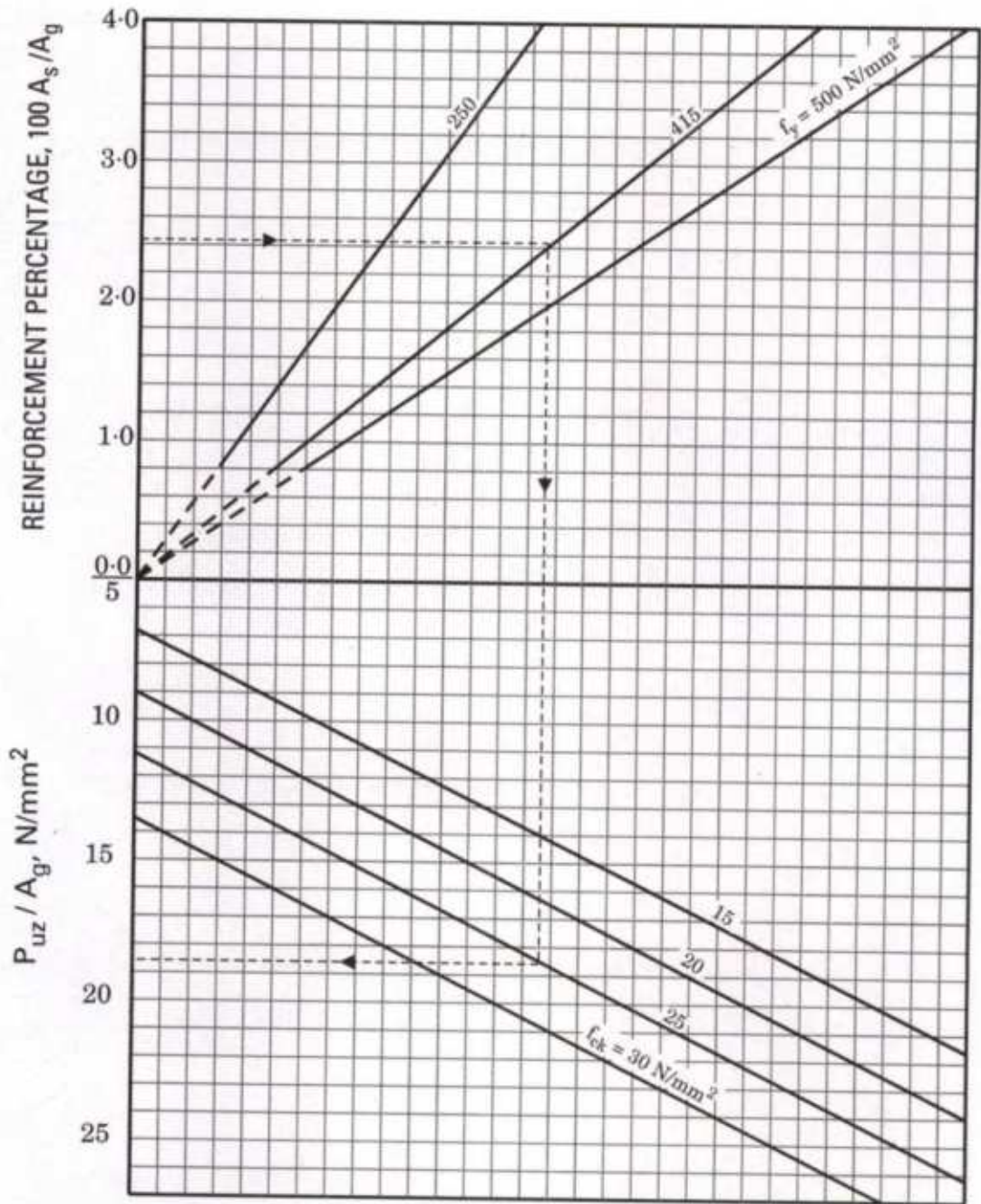

- (b) Determine the absolute bending moment in a 16 m long beam AB due to the truck loading shown in the figure. 20

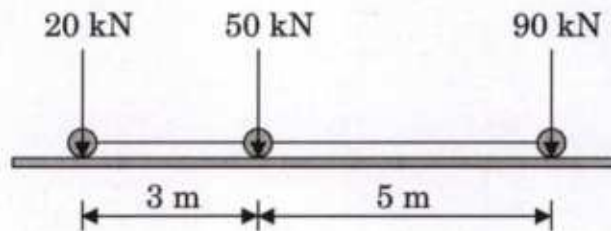
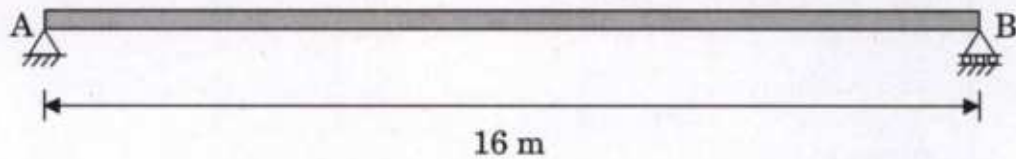

- (c) (i) Briefly discuss various factors affecting the output of power shovel to excavate earth. 10
- (ii) What are the precautions to be taken for labour safety during excavation works? 10

- Q7. (a)** A four-storey reinforced concrete (RC) office building located in seismic zone IV is shown in the figure. The RC frames are infilled with brick masonry. The lumped weights due to dead loads is 15 kN/m^2 on the floors and 12 kN/m^2 on the roof. The floors have to cater to a live load of 4 kN/m^2 on the floors and 1.5 kN/m^2 on the roof. Calculate the design seismic load on the structure at different floors using Linear Static (Equivalent Static) analysis, along x-axis.

20

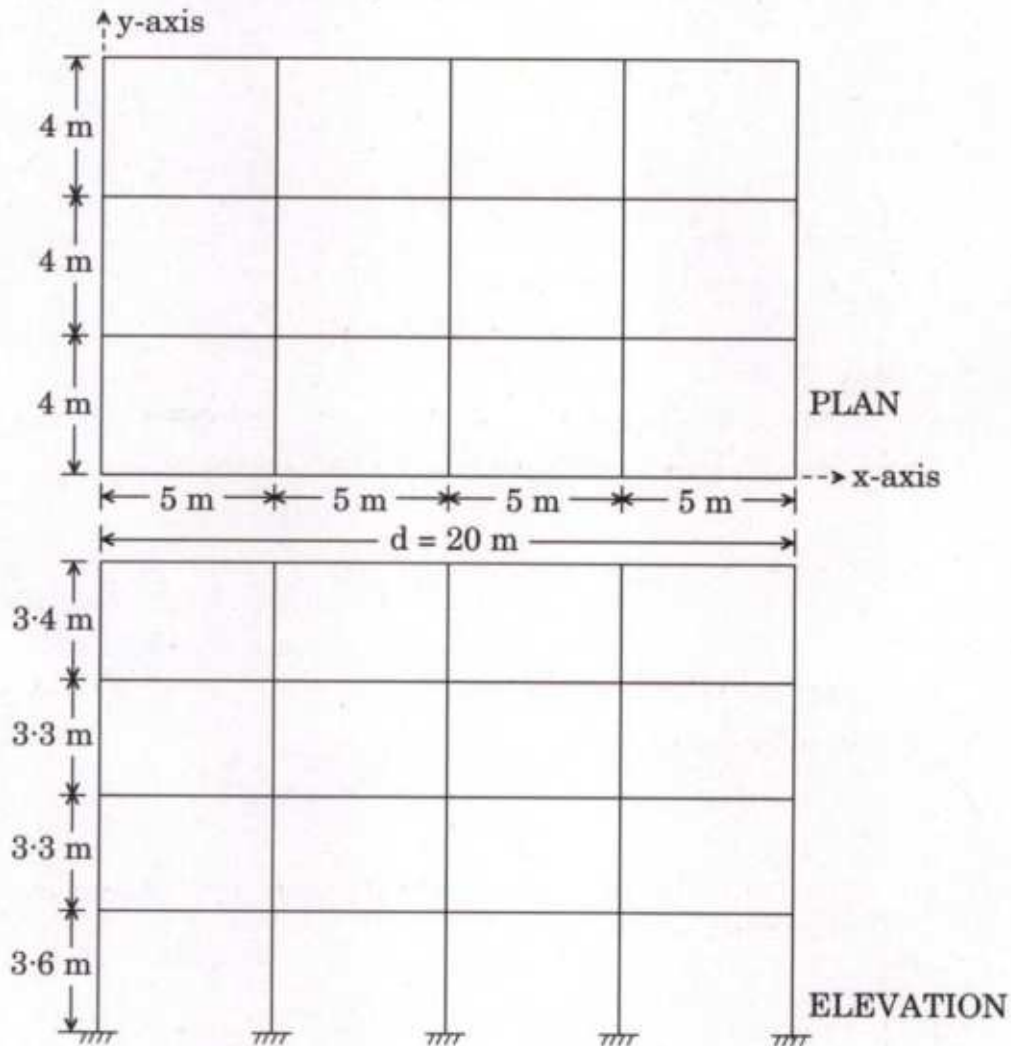

Zone factor $Z = 0.24$

Importance factor $I = 1.2$

Response Reduction Factor $R = 5$

Fundamental translational natural period $T_a = \frac{0.09h}{\sqrt{d}}$

$$\frac{S_a}{g} = \begin{cases} 2.5 & 0 < T \leq 0.55 \text{ s} \\ \frac{1.36}{T} & 0.55 < T \leq 4.0 \text{ s} \\ 0.34 & T > 4.0 \text{ s} \end{cases}$$

- (b) Analyse a continuous beam shown in the figure. During loading, the support B sinks by 12 mm. $E = 210 \text{ GPa}$, $I = 5131.6 \times 10^4 \text{ mm}^4$. EI is constant. Draw BMD and Elastic curve. 20

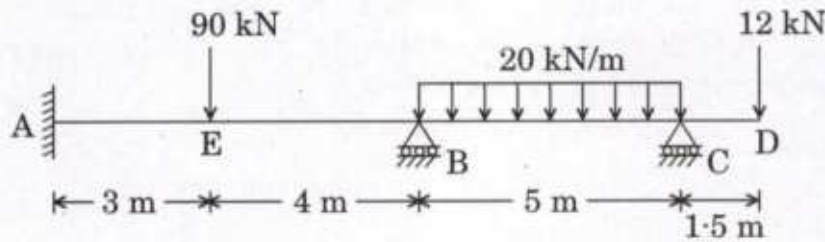

- (c) Differentiate between optimistic time estimate and pessimistic time estimate in a PERT network.

A construction company has an opportunity to submit a bid for the construction of a residential building and a commercial building. The 3 time estimates (in months) for completion of each building are as follows :

	Optimistic time (in months)	Most likely time (in months)	Pessimistic time (in months)
Residential Building	3	4	6
Commercial Building	4	6	8

Determine the expected time for completion of each building. Also analyse which building has more reliable time estimate. 20

- Q8.** (a) Design an open cylindrical water tank of 350 m^3 capacity. This tank will rest on ground and have a free-flexible joint at base. Overall height of tank is 4.0 m, including the free board of 200 mm.

Design the vertical cylindrical wall of tank and sketch the details. Consider only maximum hoop tension for entire height. 20

The following parameters may be used for design, if required.

- (1) Permissible direct tensile stress of concrete $\sigma_{ct} = 1.2 \text{ MPa}$

- (2) Permissible tensile stress of steel $\sigma_{st} = 150$ MPa up to 225 mm from water fall = 190 MPa beyond 225 mm from water fall
- (3) Molecular ratio $M = 13$
- (4) Minimum thickness required = 180 mm
- (5) Minimum % of reinforcement up to 100 mm thickness 0.24% linearly reduces to 0.16% for more than 450 mm thickness
- (6) Use 16 mm diameter, high strength deformed bar for hoop reinforcement
- (7) Use 8 mm diameter, high strength deformed bar for vertical distribution reinforcement
- (8) Minimum diameter of tank required = 11.0 m
- (9) Unit weight of water = 10 kN/m^3
- (10) Tensile stress in concrete =
$$\frac{T}{A_c + (m - 1) A_s}$$

- (b) Two loads W_1 (equal to 1.5 kN) and W_2 , resting on two inclined rough planes OA and OB are connected by a horizontal link PQ as shown in the figure. Find the maximum and minimum values of W_2 for which the equilibrium can exist. Take angle of friction for both the planes as 20° . 20

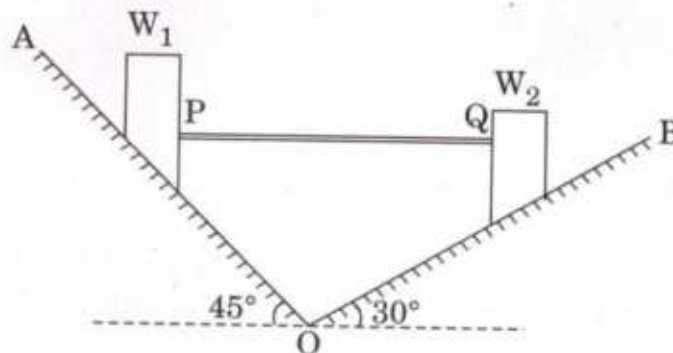

- (c) A rolled steel joist ISMB 450 is used as beam for the roof of a hall $7.5 \text{ m} \times 12 \text{ m}$. Thickness of RC slab is 125 mm . The rolled steel joists are spaced at 3 m centre to centre. The floor finishing load is 1.5 kN/m^2 and the roof slab has to support a live load of 4 kN/m^2 . Assume the self-weight of the beam as 1 kN/m . Take the width of bearing for the beam as 300 mm . The limiting deflection for the beam is $\text{span}/240$. $\gamma_{mo} = 1.1$, $f_y = 250 \text{ MPa}$. Check the adequacy of the section against any two modes of failure.

20

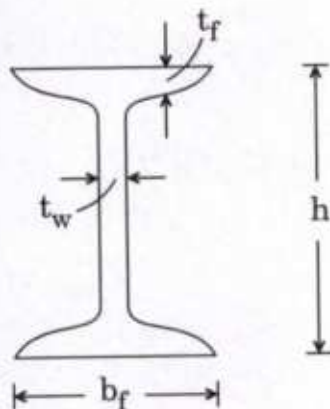

Properties of ISMB 450 :

Elastic Section Modulus = $30390.8 \times 10^3 \text{ mm}^3$

Plastic Section Modulus $Z_p = 1533.36 \times 10^3 \text{ mm}^3$

Depth of section $h = 450 \text{ mm}$

Width of flange $b_f = 150 \text{ mm}$

Thickness of flange $t_f = 17.4 \text{ mm}$

Thickness of web $t_w = 9.4 \text{ mm}$

Radius at root = 15 mm

$$\text{Shear capacity } V_d = \frac{A_v \cdot f_y}{\sqrt{3} \gamma_{mo}}$$

$$\text{Design bending strength } M_d = \frac{\beta_b \cdot Z_p \cdot f_y}{\gamma_{mo}}$$

Slenderness ratio	Design Compressive Stress (f_{cd})
100	107
110	94.6
120	83.7

$$\text{Buckling strength } F_b = (b_1 + n_1) t_w \cdot f_{cd}$$

$$\text{Capacity of web at its connection to the flange } F_w = \frac{(b_1 + n_2) t_w \cdot f_{yw}}{\gamma_{mo}}$$

The section ISMB 450 may be assumed as plastic.

