

## ELECTRONICS AND TELECOMMUNICATION ENGINEERING

## PAPER—I

Time Allowed : Three Hours

Maximum Marks : 300

**QUESTION PAPER SPECIFIC INSTRUCTIONS**

**Please read each of the following instructions carefully before attempting questions**

There are EIGHT questions divided in TWO Sections.

Candidate has to attempt FIVE questions in all.

Question Nos. 1 and 5 are compulsory and out of the remaining, THREE are to be attempted choosing at least ONE question from each Section.

The number of marks carried by a question/part is indicated against it.

Wherever any assumptions are made for answering a question, they must be clearly indicated.

Diagrams/Figures, wherever required, shall be drawn in the space provided for answering the question itself.

Unless otherwise mentioned, symbols and notations carry their usual standard meanings.

Attempts of questions shall be counted in sequential order. Unless struck off, attempt of a question shall be counted even if attempted partly.

Any page or portion of the page left blank in the Question-cum-Answer Booklet must be clearly struck off.

Answers must be written in ENGLISH only.

**Values of constants which may be required**

Electron charge	= $-1.6 \times 10^{-19}$ coulomb
Free space permeability	= $4\pi \times 10^{-7}$ henry/m
Free space permittivity	= $(1/36\pi) \times 10^{-9}$ farad/m
Velocity of light in free space	= $3 \times 10^8$ m/s
Boltzmann constant	= $1.38 \times 10^{-23}$ J/K
Planck constant	= $6.626 \times 10^{-34}$ J s

**SECTION—A**

1. (a) (i) Calculate the temperature at which silicon (Si) semiconductor tends to behave like a metal. 6
- (ii) Prove that reverse saturation current approximately doubles for every 10 °C rise in temperature in a semiconductor diode. 6
- (b) (i) Prove that when two resistors are connected in parallel, the equivalent resistance of the combination is always smaller than that of smaller resistor. 6
- (ii) A conductor has resistance 5.4 Ω at 20 °C and 7 Ω at 100 °C. Determine the resistance of the conductor at 0 °C. 6
- (c) What is 'line imperfection defect' in a crystal? How does it affect the properties of a metal? 12
- (d) (i) Enumerate the different performance indices based on which an engineer selects an instrument. 5
- (ii) What is the SI system of units? Mention some (at least four) well-defined units maintained by the International System of Units. 7
- (e) In the circuit shown in the figure below,  $I = 1 \text{ mA}$  is a DC current and  $v_{in}(t)$  is a sinusoidal voltage with small amplitude :

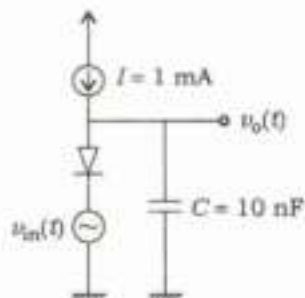

Representing the diode by its small signal resistance  $r_d$ , which is a function of  $I$ , sketch the circuit for determining  $v_o(t)$  and thus find out cutoff frequency  $f_H$ . (Assume  $V_T = 25 \text{ mV}$  at room temperature) 12

2. (a) (i) Find the equilibrium hole concentration  $p_0$  at 300 K of Si sample doped with phosphorus impurity if Fermi level energy ( $E_F$ ) of doped Si is 0.407 eV more than intrinsic level energy ( $E_i$ ). Given  $n_i = 1.5 \times 10^{10}$  atoms/cm<sup>3</sup> and  $kT = 0.0259$  eV. 10
- (ii) A filter capacitor  $C$  is used to smooth out the pulses from the full-wave rectifier as shown in the figure below :

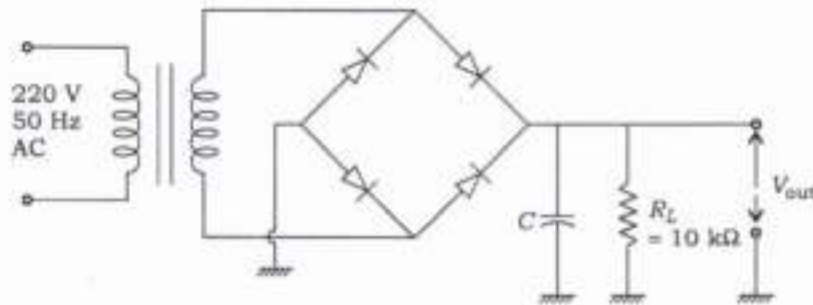

Find the value of  $C$  so that the steady current supply to load  $R_L$  can be maintained. 10

- (b) (i) What is the principle of nanomagnetism? Based on the specific properties of nanomagnetism, write its applications in engineering field. 12
- (ii) Classify insulating materials according to their temperature stability limit and give few examples of each grade. 8
- (c) (i) What are the signal conditioning requirements for measurements with strain gauges? How can you compensate errors due to temperature in strain gauge measurements? 10
- (ii) A piezoelectric transducer is subjected to a force of 6 N. The dimension of the transducer is given as 6 mm × 6 mm × 1.3 mm. The charge sensitivity and the dielectric constant of the transducer are given as 160 pC/N and  $1250 \times 10^{-11}$  F/m respectively. Calculate the voltage generated and the deflection caused to the surface. The Young's modulus of elasticity of the material is given as  $12 \times 10^6$  N/m<sup>2</sup>. 10

3. (a) (i) Calculate the range of base resistance ( $R_B$ ) so that transistor  $T_1$  never operates in saturation region : 10

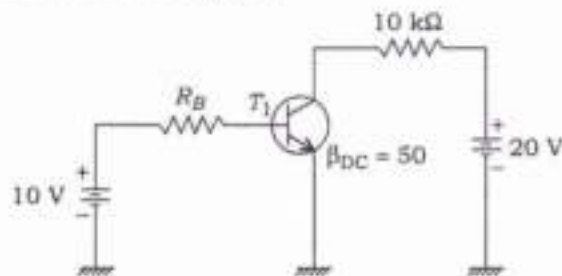

- (ii) An amplifier has a bandwidth of 500 kHz and voltage gain of 100. What should be the amount of negative feedback if the amplifier bandwidth is extended to 5 MHz? What will be the new gain after negative feedback is introduced? 10
- (b) (i) What are HTSC? Write the important applications of superconducting materials and HTSC. 10
- (ii) "A ceramist can alter the properties of ceramic." Justify the statement. 10
- (c) (i) Explain, with necessary diagrams, how you can detect the proximity of an object. 12
- (ii) The spring constant and seismic mass of an accelerometer are 3300 N/m and  $5 \times 10^{-2}$  kg respectively. The maximum displacement is  $\pm 0.25$  m (before the mass hits the stops). Calculate (1) the maximum measurable acceleration in  $g$  and (2) the natural frequency. 8

4. (a) (i) Consider a differential amplifier as shown in the figure

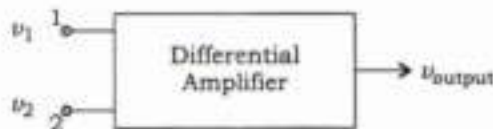

where the first set of signals is  $v_1 = 50 \mu\text{V}$ ,  $v_2 = -50 \mu\text{V}$  and the second set of signals is  $v_1 = 1050 \mu\text{V}$ ,  $v_2 = 950 \mu\text{V}$ . If the common-mode rejection ratio is 100, calculate the percentage difference in output voltage obtained for the two sets of input signals. 10

- (ii) (1) Repeat part (a)(i), if the common-mode rejection ratio is  $10^5$ . 3
- (2) Draw the conclusion by comparing part (a)(i) and part (a)(ii)(1). 2
- (iii) Explain photovoltaic potential in short. 5
- (b) (i) What is polarization mechanism in dielectric material? Explain active and passive dielectrics with suitable example. 10
- (ii) Explain cermets. How are they different from fibre reinforced composites? Write four applications of each. 10

- (c) (i) What are the elements of a generalized data acquisition system? Draw a multi-channel data acquisition system using single A/D converter and briefly explain its working. 14

- (ii) Explain, with a diagram, the operation of a force balance current telemetering system. 6

### SECTION—B

5. (a) (i) Find the value of resistance  $R$  in the figure below if the voltmeter reads 12 V and ammeter reads 0.100 A : 6

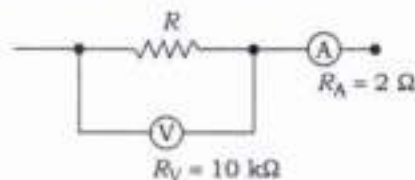

- (ii) Repeat part (a)(i) for the circuit arrangement given in the figure below : 6

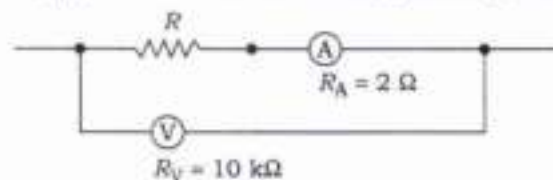

- (b) Copper has an atomic radius of 0.1278 nm. Calculate the atomic density (number of atoms per unit) in (1 0 0) plane of copper (FCC). 12

- (c) How can you convert a galvanometer into an ammeter and a voltmeter? A PMMC galvanometer of 6  $\Omega$  resistance reads up to 60 mA. Determine the value of the resistance (i) when connected in parallel to enable the instrument to read up to 1.20 A and (ii) when connected in series to enable it to read 12 V. 12

- (d) In the circuit given below,  $v_C(0^-) = v_0$ , while the inductor is not charged. The switch that is initially open is closed at  $t = 0$ . Also  $L = C$  in terms of numerical value. Find  $R$  (positive value) so that the circuit is critically damped : 12

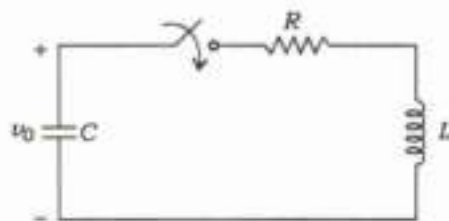

- (e) In the feedback circuit shown in the figure below,  $h_{fe}$  is very large. Identify the type of feedback, and (i) find the feedback factor  $\beta$  and overall transresistance with feedback and (ii) overall voltage gain,  $A_{v_{us}} = \frac{v_o}{v_s}$  : 12

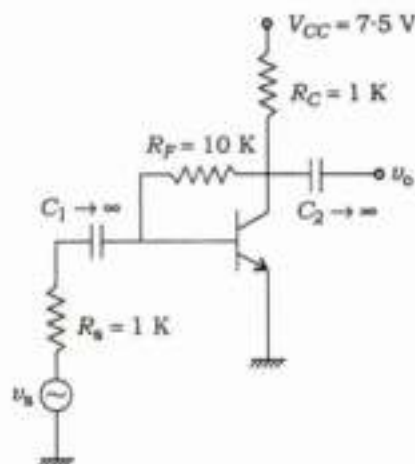

6. (a) (i) A voltage source delivers 4 A when the load connected is  $5 \Omega$  and 2 A when the load is  $20 \Omega$ . What is the maximum power it can deliver? Also calculate power transfer efficiency with  $R_L = 5 \Omega$  and power transfer efficiency when it delivers 50 W. 10

(ii) Find the Thévenin equivalent of the circuit at  $a-b$  :

10

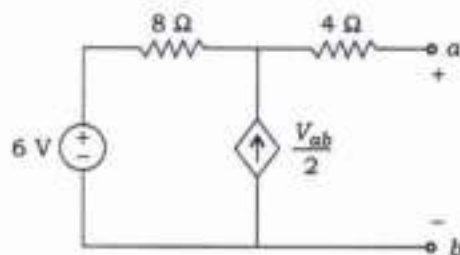

- (b) (i) For the circuit shown in the figure below, it is known that the voltage across the capacitor is  $v_C(t) = 20 \sin\left(2t + \frac{\pi}{6}\right)$  V for  $t \geq 0$ . Compute and plot the instantaneous power absorbed by the capacitor and energy stored by the capacitor over  $[0, t]$  :

8

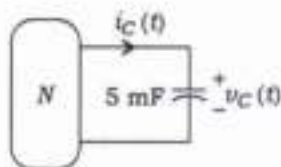

- (ii) The op-amp in the figure assumed to be ideal  $R_1 = 20 \text{ k}\Omega$ ,  $R_2 = 40 \text{ k}\Omega$  and  $C = 10 \mu\text{F}$  :

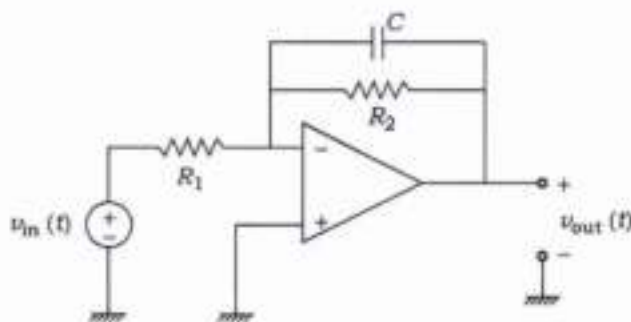

- (1) Use nodal to construct a first-order differential equation describing the input-output relationship of the voltage.
- (2) Laplace transform your equation of (1) and solve  $v_{out}(s)$  in terms of  $v_{in}(s)$  and  $v_C(0^-)$ .
- (3) If  $v_{in}(t) = 2e^{-2t}u(t)$  V and  $v_C(0) = 0$ , find  $v_{out}(t)$ .

12

- (c) A certain person with poor television reception and no access to cable TV intends to use the amplifier in the figure shown below as booster amplifier between his antenna and his television :

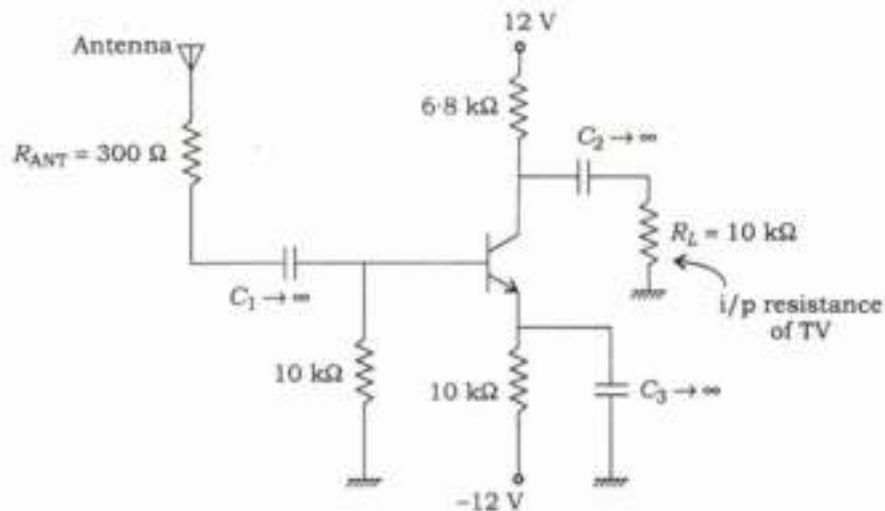

The transistor has high frequency capacitances with  $C_{bc} = 4$  pF,  $C_{be} = 2$  pF,  $C_{ce} = 1$  pF and  $\beta \approx 100$ . Calculate low-pass dominant pole frequency and determine whether this amplifier performs adequately. (Assume  $V_T = 26$  mV at room temperature)

20

7. (a) In the circuit shown in the figure below,  $|V_1| = 200$  V,  $V_2 = 200 \angle 0^\circ$  V and  $|I| = 12$  A. The total power absorbed by the circuit is 1.8 kW. Find  $R_1$ ,  $X_1$  and  $X_2$  :

20

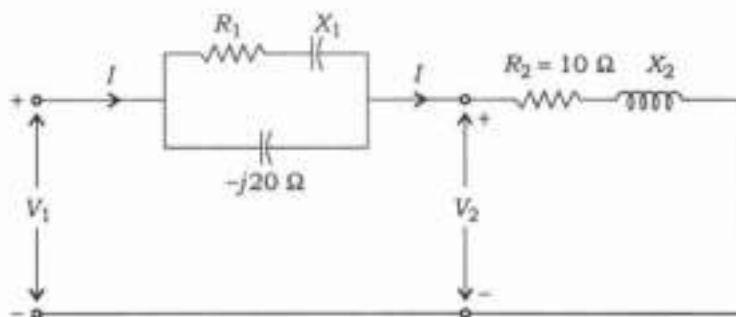



- (b) (i) Determine the voltage across the resistor in the circuit of the figure shown below using phasor concept for  $v_1(t) = 20\cos(\omega t + 53.13^\circ)$  V,  $v_2(t) = 19.68\sin(\omega t + 152.8^\circ)$  V and  $v_3(t) = 4.215\cos(\omega t + 71.61^\circ)$  V : 6

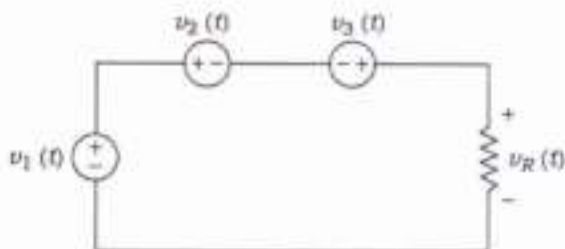

- (ii) Find the Laplace transform of the sawtooth sketched in the figure below : 4

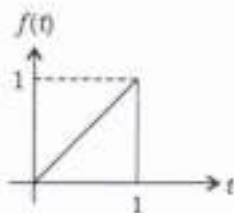

- (iii) The figure below shows a simplified model of an audio amplifier containing an ideal transformer. The input voltage is at 2 kHz with a magnitude 1 V r.m.s. The load is a loudspeaker, represented by  $4\ \Omega$  resistance :

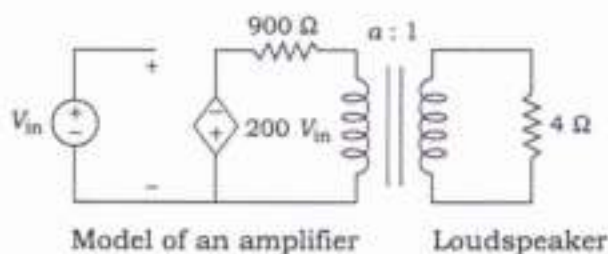

- (1) Find the average power delivered to the  $4\ \Omega$  load if it is directly connected to the amplifier (i.e., with the transformer removed).
- (2) With the transformer connected and with turns ratio  $a = 5$ , find the average power delivered to the load.

10

- (c) (i) Implement the logic function shown below with a static CMOS gate : 10

$$\text{Out} = \overline{ABC} + \overline{ABC} + \overline{ABC}$$

- (ii) A certain counting type 12-bit ADC operates with FSR = 0 to 10 V and clock frequency  $f_{\text{clk}} = 1 \text{ MHz}$ . Determine the dynamic range of the converter, conversion time, conversion rate and Nyquist frequency of the converter. 10

8. (a) A shunt generator delivers 50 kW at 250 V when running at 400 r.p.m. The armature and field resistance are  $0.02 \Omega$  and  $50 \Omega$  respectively. Calculate the speed of the machine when running as a shunt motor and taking 50 kW at 250 V. Given, total voltage drop in the brushes is 2 V. 20

- (b) (i) The linear resistive circuit shown in the figure below has four independent sources. Three of them have fixed value, only one,  $i_{s3}$  is adjustable :

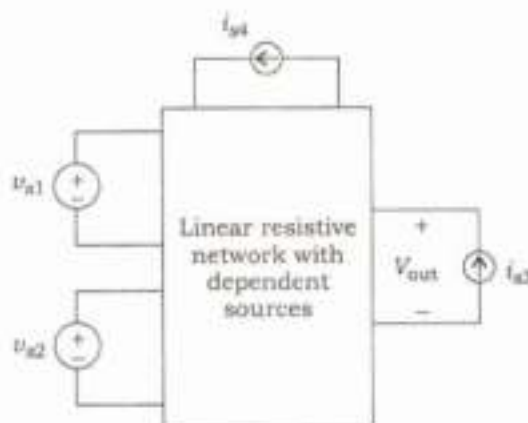

The table shows the four sets of measurements taken in a laboratory :

$i_{s3}$ (mA)	$V_{\text{out}}$ (V)
1	6
2	10
5	?
?	0

Complete the last two rows of the table. For the data in row 3, find the power delivered by the current source  $i_{s3}$ . 12

- (ii) Consider the three-source circuit of the figure below :

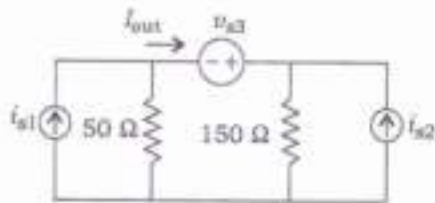

Compute  $I_{out}$  using superposition theorem.

8

- (c) (i) For the circuit shown in the figure below, determine the output voltage if the input  $v_{in}(t) = 100 \sin(2\pi \times 10^3 t)$  mV. Assume that the op-amp is an ideal op-amp and MOSFET parameters are  $\mu_n \text{cox} = 100 \mu\text{A}/\text{V}^2$ ,  $V_{tn} = 1 \text{V}$ ,  $W = 10 \mu\text{m}$  and  $L = 2.5 \mu\text{m}$  :

15

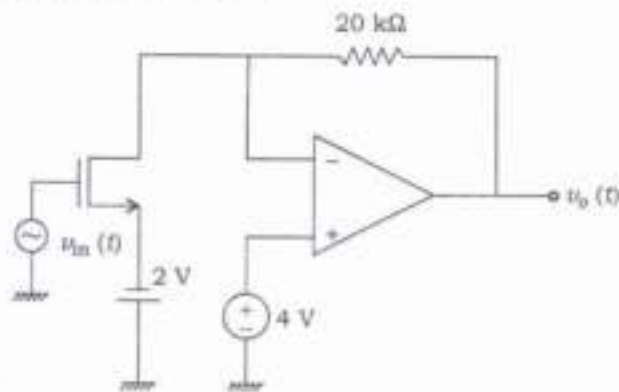

- (ii) Draw a block diagram of a 4 to 2 encoder. Label all inputs and outputs. How is the 4 to 2 encoder different from 4 to 1 multiplexer?

5

\*\*\*

