

ALL JE / AE Exams



शुरुआत selection की

CIVIL ENGINEERING

Testing of Aggregates

ZERO TO HERO SERIES

By Pramod sir LIVE! 5:00 PM

7



WELCOME
TO Adda247

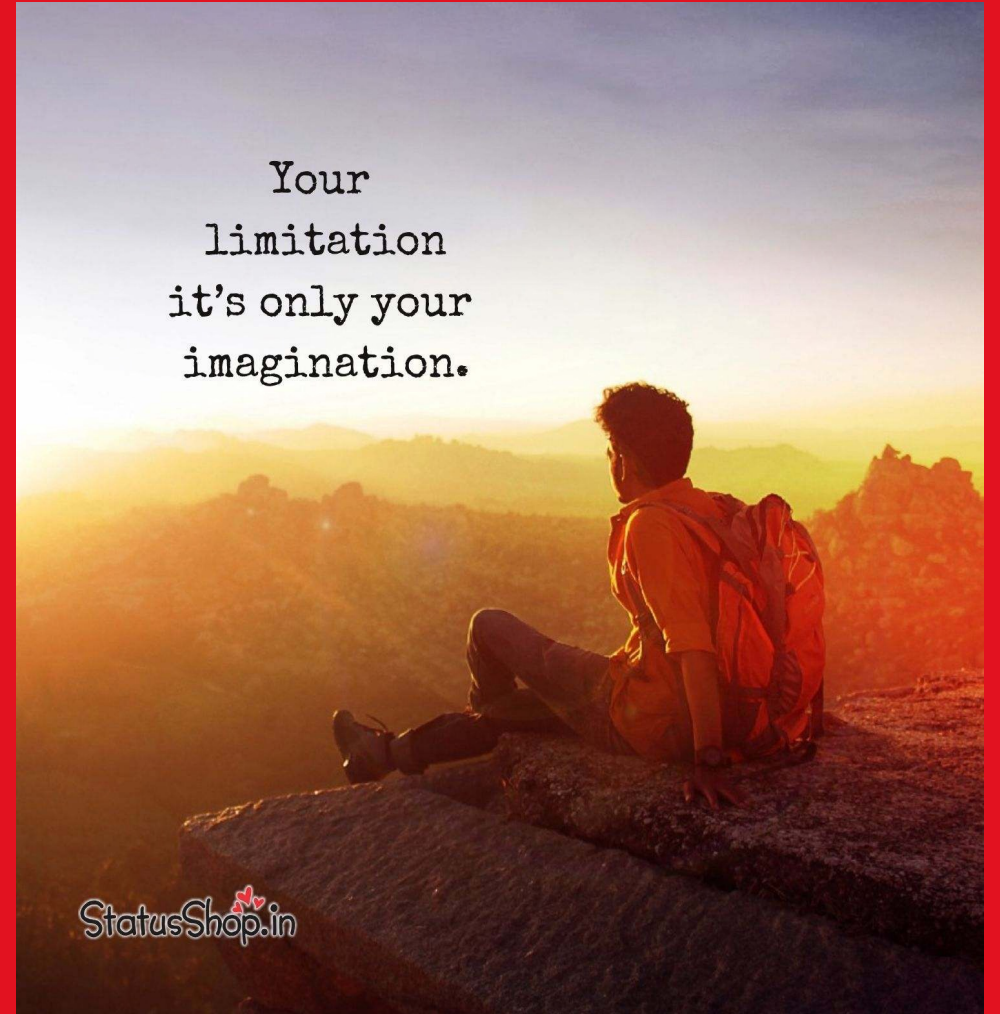



SUBSCRIBE NOW

Engineers Adda247
YouTube Channel

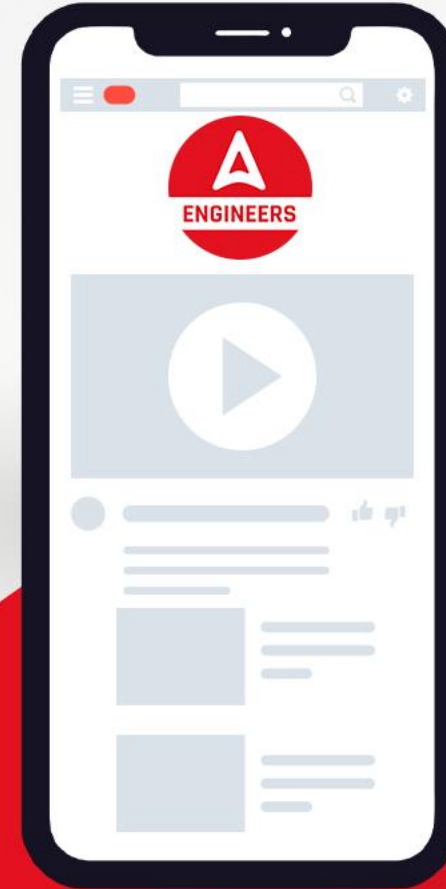

USE MAX DISCOUNT CODE Y579

Aggregate Crushing Test

The strength of aggregate is defined as the resistance of the aggregate against gradual loading. The strength of aggregate is determined by the Crushing Value Test on aggregates.

The aggregates passing through a 12.5 mm IS sieve and retained on a 10 mm IS sieve are taken. These aggregates are subjected to gradual loading of 40 tonnes with the help of a plunger

USE MAX DISCOUNT CODE Y579

Adda247

Adda247

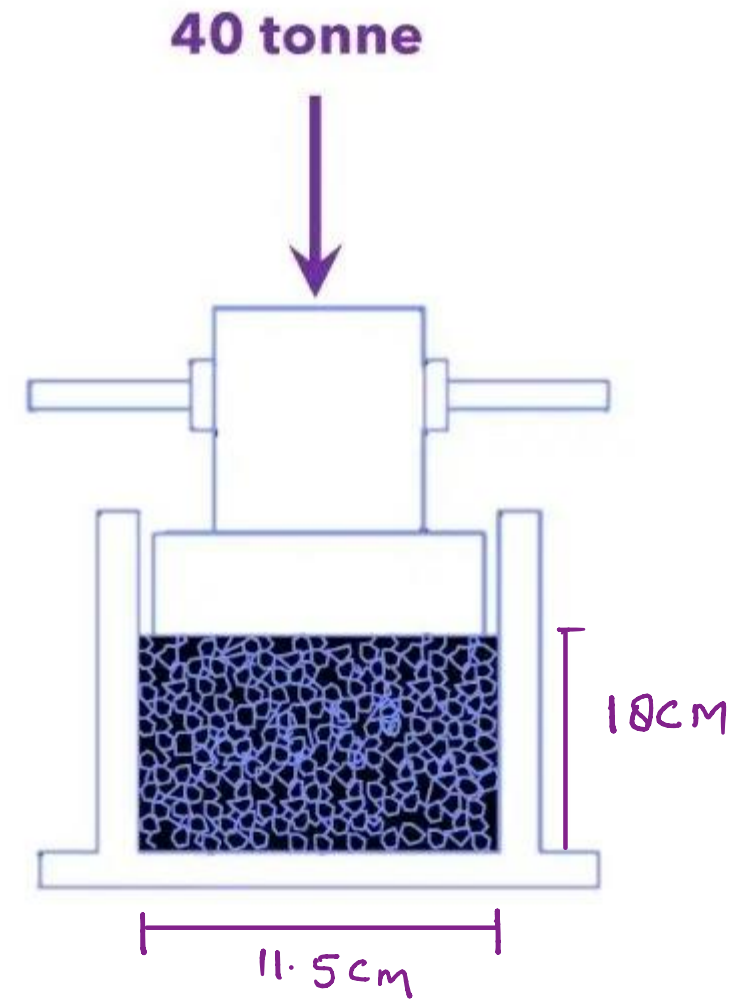

The crushed aggregates are then passed through a 2.36 mm sieve.

The weight of the aggregates passing through the 2.36 mm sieve, expressed as the percentage of the total weight of aggregates, is referred to as Aggregate Crushing Value (ACV).

Lesser is the ACV, more will be the strength of aggregate. ACV less than 10 indicates exceptionally strong aggregate whereas, ACV greater than 35 indicates weak aggregate.

Aggregate Crushing Value (ACV) = $\frac{\text{weight of material passing through 2.36 mm sieve}}{\text{weight of total aggregate}}$

Aggregate Impact Test

The toughness of the aggregate is defined as the ability to resist impact loading. The toughness of the aggregate is determined by Impact Value Test on aggregates. The aggregates passing through a 12.5 mm IS sieve and retained on a 10 mm IS sieve are taken.

This sample of aggregate is subjected to 15 blows with the help of a metallic hammer having a mass of 13.5-14 kg, free-falling from a height of 38 cm.

USE MAX DISCOUNT CODE **Y579**

Adda247

Adda2



The aggregates after impact are passed through the sieve of size 2.36 mm. The weight of aggregates passing through the 2.36 mm sieve, expressed as the percentage of the total weight of aggregates is referred to as Aggregate Impact Value (AIV). Lesser is the AIV, more will be the toughness of the aggregate.

The AIV of aggregate should not exceed 30% for wearing course, 35% for bituminous macadam and 40% for water-bound macadam.

Aggregate Impact Value (AIV) = $\frac{\text{weight of material passing through 2.36 mm sieve}}{\text{weight of total aggregate}}$

Aggregate Abrasion Test

Hardness is the property of aggregate that allows it to withstand wear and tear (abrasion). The hardness of the aggregates can be determined by Deval Abrasion Test, Dorry's Abrasion Test and Los Angeles Abrasion Test. The Los Angeles Abrasion Test on aggregates is the standardized method for determining the hardness of aggregates in India.

In this test, aggregates passing through a 12.5 mm sieve and retained on a 10 mm sieve are placed in a cylinder having steel balls in it. The sample is subjected to abrasion by rotating the cylinder 500 times at the speed of 30 to 33 rpm.



↓
5-10 kg.

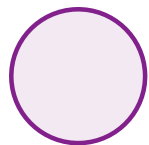

→ Dia - 48 mm
wt - 340 - 345 mm
6-12 NO'S

The aggregates after the test are passed through a 1.7 mm sieve and the weight of the aggregates passing through the sieve is noted, which when expressed in terms of percentage of the total weight of aggregates is referred to as Aggregate Abrasion Value.

Lesser abrasion value means more hardness of aggregate. Abrasion value should not exceed 35% for bituminous macadam and 40% for WBM base course.

Los Angeles Abrasion Value = $\frac{\text{weight of material passing through 1.7 mm sieve}}{\text{weight of total aggregate}}$

Flakiness Index Test

The flakiness index of the aggregates is defined as the percentage by weight of the aggregates in the sample whose least dimension is less than 0.6 times the mean dimension. The flakiness index test on aggregates is performed using Thickness Gauge.

This test does not apply to aggregates with a size of less than 6.3 mm. An aggregate sample having a minimum of 200 pieces is considered and each aggregate is passed through respective gauges of the thickness gauge.

The weight of the aggregates passing through various gauges is noted which when expressed as a percentage of the total weight of aggregate sample is referred to as Flakiness Index.

Flakiness Index = $\frac{\text{Weight of material passing the various gauges}}{\text{Total weight of the sample}}$

USE MAX DISCOUNT **CODE Y579**

Adda247

Adda247

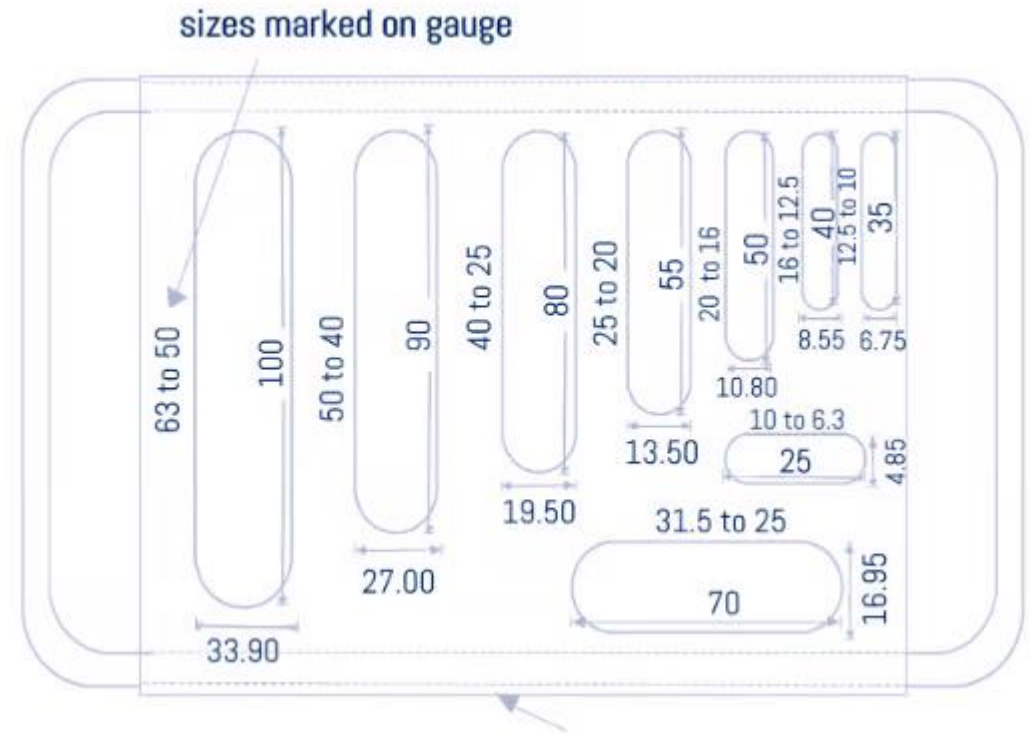

Elongation Index Test

The elongation index of the aggregates is defined as the percentage by weight of the aggregates present in the sample having their greatest size greater than 1.8 times of their mean size. Elongation index test on aggregates is performed using Length Gauge.

This test does not apply to aggregates with a size of less than 6.3 mm. An aggregate sample having a minimum of 200 pieces is considered and each aggregate is passed through the respective gauges of the length gauge. The weight of aggregates retained over various gauges is noted which when expressed in terms of the total weight of the aggregates is referred to as Elongation Index.

Elongation Index = $\frac{\text{Weight of material retained on various gauges}}{\text{Total weight of the sample}}$

USE MAX DISCOUNT **CODE Y579**

Adda 24/7

Adda

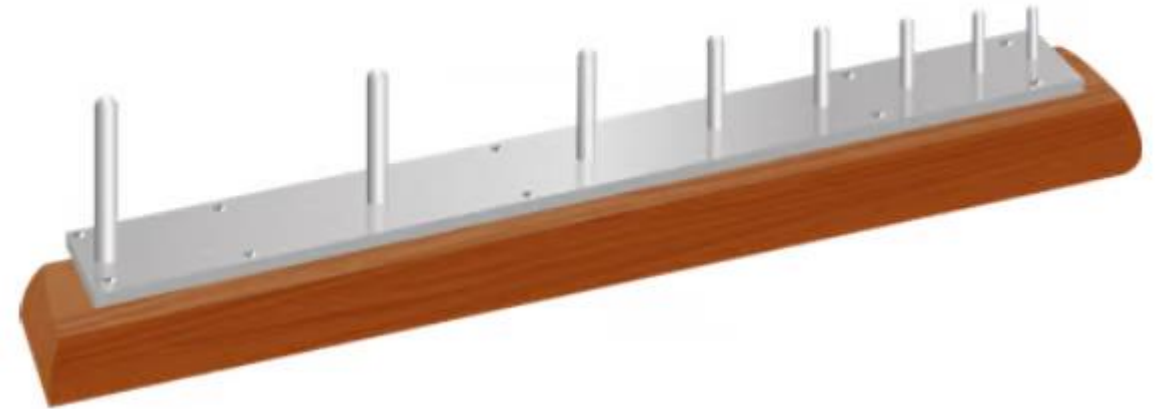

Angularity Test

The angularity test on aggregates determines the angularity of aggregates in a sample. The angularity of the aggregates is measured in terms of Angularity Number which is defined as the amount by which the percentage of voids in it, exceeds 33.

For this test, a quantity of single-sized aggregate is filled into a metal cylinder of known capacity and compacted. The percentage of void in the aggregate sample is determined. Angularity number is calculated using the following equation -

$$\text{Angularity Number} = 67 - 100W/C \times G$$

Where,

W = weight of the aggregate required to fill the cylinder

C = weight of water needed to fill the cylinder

G = specific gravity of aggregate

For well compacted, single-sized rounded aggregate percentage air void is 33% i.e., angularity number is zero. Angularity number will be expressed as the nearest whole number.

The angularity number value varies in the range of 0 to 11. A higher value of angularity number indicates that aggregates are more angular.



SOUNDNESS

Soundness of the aggregate can be defined as its resistance against weathering action. Repeated cycles of freezing and thawing can cause the aggregates to disintegrate.

The soundness test on aggregates is meant to investigate the resistance of aggregates against weathering action by subjecting them to accelerated weathering test cycles.

Aggregates of a particular size are wetted in a saturated solution of sodium sulphate or magnesium sulphate for 16 - 18 hours, then dried to a constant weight in an oven at 105 - 110°C. This cycle is repeated 5 times and the weight loss of aggregates is determined after removing all undersized particles. Loss in weight should not exceed 12% in test with Sodium sulphate and 18% in test with Magnesium sulphate.

Specific Gravity and Water Absorption Test

The specific gravity of aggregates normally used in pavement construction ranges from 2.6 to 2.9. Water absorption value greater than 0.6% is unsatisfactory. Water absorption from 0.1% to about 2% is normally used in road surfacing.



USE MAX DISCOUNT **CODE Y579**

Adda **247**

Adda **247**

APP FEATURES

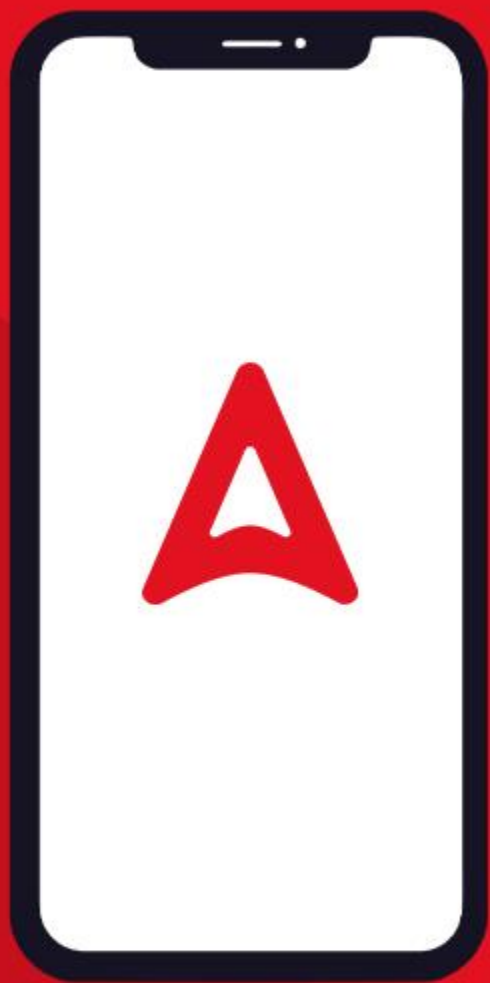

Download Now
Adda247 APP



Premium Study Material



Current Affairs



Job Alerts



Daily Quizzes



Subject-wise Quizzes



Magazines



Power Capsule



Notes & Articles



Videos

Use
Y579
Max Discount

Which among the following indicates shape test for aggregate?

BECIL NMRC J.E. CIVIL 15-09-2019

- (a) CBR Test
- (b) Deval Test
- (c) Elongation Test
- (d) Log Angeles

Use
Y579
Max Discount

The binding material in the mortar is also called

SSC JE 23-09-2019 (morning)

- (a) Admixture
- (b) Adulterant
- (c) Paste
- (d) Matrix

Adda247

Use
Y579
Max Discount

Which of the following cement is supposed to be the best cementing material and is well burnt cement?

SSC JE 23-09-2019 (morning)

- (a) Tricalcium silicate
- (b) Tetracalcium alumino ferrite
- (c) Dicalcium silicate
- (d) Tricalcium aluminate

Use
Y579
Max Discount

The combined name for the two tests-elongation index and flakiness index is

RRB JE CBT-II 28-08-2019 (Evening)

- (a) Stability test
- (b) Shape test
- (c) Surface test
- (d) Strength test

Use
Y579
Max Discount

Minimum voids in aggregates can be obtained by using -

RRB JE CBT-II 28-08-2019 (Morning)

- (a) Manufactured aggregates
- (b) Aggregates of varying sizes
- (c) Aggregates all of the same size
- (d) Aggregates of the same shape

Use
Y579
Max Discount

Which of the following characteristics of ballast makes it unsuitable for use?

RRB JE CBT-II 28-08-2019 (Morning)

- (a) High modulus
- (b) High water absorption
- (c) High stability
- (d) High resilience

Use
Y579
Max Discount

Which of the following is NOT a pre caution to be adopted for concreting in sub-zero condition?

UPRVUNL JE 2019

- (a) Use of air entraining agents
- (b) Admixture of anti-freezing material
- (c) Sprinkling of water over aggregates
- (d) Electrical heating of concrete mass

Use
Y579
Max Discount

When the angular number of an aggregate sample is 2, it indicates that the aggregates are more _____

UPRVUNL JE 2019

- (a) Rounded
- (b) Angular
- (c) Flaky
- (d) Partly rounded

Use
Y579
Max Discount

The bulking of sand is depend upon –

Hariyana SSC JE Afternoon Session (11-04-2018)

- (a) Chemical reaction
- (b) Type of water
- (c) Fineness of sand
- (d) Quantity of sand

Use
Y579
Max Discount

I.S. Sieve Nos. 10 mm and 4.75 mm are generally used for grading of

SSC JE 20-01-2018 (Morning Shift)

- (a) Coarse aggregates
- (b) Fine aggregates
- (c) Both coarse aggregates and fine aggregates
- (d) None of these

Use
Y579
Max Discount

The test strength of the sample is taken as the average of the strength of

(SSC JE 01-03-2017 Morning Shift/
SSC JE CWC & MES 2011)

- (a) 2 specimens
- (b) 3 specimens
- (c) 4 specimens
- (d) 5 specimens

Use
Y579
Max Discount

The light weight aggregates are obtained from

SSC JE 23-01-2018 (Morning Shift)

- (a) Sedimentary rocks
- (b) Metamorphic rocks
- (c) Igneous rocks
- (d) Volcanic source

Use
Y579
Max Discount

Crushing value of coarse aggregates for making concrete for buildings should not be more than:

LMRC J.E. 13-05-2018 (Shift-I)

- (a) 15%
- (b) 30%
- (c) 45%
- (d) 60%

Use
Y579
Max Discount

Los Angeles machine is used to test the aggregate for

M.P. Sub Engg. 01-09-2019 9.00 am

(SSC JE 4 March 2017 Morning Shift)

(SSC-JE 2018)

- (a) Crushing strength
- (b) Water absorption
- (c) Impact value
- (d) Abrasion resistance

Use
Y579
Max Discount

Given an example for flaky shape of aggregate

M.P. Sub Engg. 02-09-2019 2.00 pm

- (a) Pit sand
- (b) Crushed rock
- (c) Boown sand
- (d) Laminated rock

Use
Y579
Max Discount

Which one of the following construction materials is NOT a constituent of cement concrete?

M.P. Sub Engg. 02-09-2018 2.00 pm

- (a) Cement
- (b) Stone
- (c) Mortar
- (d) Lime

Use
Y579
Max Discount

If the least lateral dimension of aggregate is less than 0.6 times of its mean dimension, the aggregate is classified as _____.

SSC JE 24-01-2018 (Evening Shift)

- (a) Angular
- (b) Flaky
- (c) Irregular
- (d) Rounded

Use
Y579
Max Discount

Spot the odd statement –

SSC JE 23-01-2018 (Evening Shift)

- (a) Rounded aggregate
- (b) Irregular or partly rounded aggregate
- (c) Angular flaky aggregate
- (d) single-size aggregate



SUBSCRIBE NOW

Engineers Adda247
YouTube Channel

Engineers Adda
SUPERSTARS

ENGINEERS

SSC JE 2022 Pre
QUALIFIED Result

 Prateek Kumar Singh 220110145	 Sarthi Singh 301030710	 Babbar Singh 2411100704	 Prateek Kumar 3003101410	 Harsh Jindal 3208100456	 Prateek Khandelwal 3010104232	 Aditya Kumar 2003100534	 Anish KJ 2201108788
 Haroon Kumar 3001300723	 Rajan Singh 2411101788	 Yashwanth Agarwal 3001100530	 Abhishek Kumar 0302100	 Sandeep Pillai 0601100292	 N. Smita 2201100336	 Rajat 301100014	 Pradyumn Kumar Singh 3001102764
 Adarsh Kumar 3012102306	 Anshul Kumar 2400102046	 Abhishek Kumar 3000050149	 Adarsh Kumar 30000043004	 Aditya Y. Kumar 0205000610	 Lakh Kumar 2201100734	 Abhinav Kumar 0011001139	
 HEMANT KUMAR POPPALA 3001102001	 Hemant Kumar 50002237922	 Rajan Singh 2411101788	 Prateek 1801100007	 Anshul Kumar 4200300017	 Anish Kumar 1300200		

and
Many More

USE MAX DISCOUNT **CODE Y579**

Adda **247**

Adda **247**

USE MAX DISCOUNT **CODE Y579**

Adda **247**

Adda **247**

USE MAX DISCOUNT **CODE Y579**

Adda **247**

Adda **247**