

R3KP- N- MCH

MECHANICAL ENGINEERING

PAPER - II

Time Allowed: Three Hours

Maximum Marks : 300

QUESTION PAPER SPECIFIC INSTRUCTIONS

Please read each of the following instructions carefully
Before attempting questions

There are EIGHT full questions in this question paper with sub-sections in each question.

Candidate has to attempt FIVE full questions.

Question Nos. 1 and 2 are compulsory and out of the remaining six, any THREE are to be attempted in full. The first THREE optional questions in the order of their appearance in the answer book will only be evaluated.

The number of marks carried by a question/part is indicated against it.

All parts of the Question must be answered at one place.

Wherever any assumptions are made for answering a question, they must be clearly indicated.

Unless otherwise mentioned, symbols and notations have their usual standard meanings.

Answers must be written in ENGLISH only.

Candidates should write the exam on the assumption that all questions are correct. If the candidate still doubts the accuracy of any numeric constant, assume its value and specify it clearly in the answer of the concerned question.

R3KP- N- MCH/19

[P.T.O]

- 1 (a) Locate the centre of gravity of the axi-symmetric homogenous solid body shown below about the origin. 15

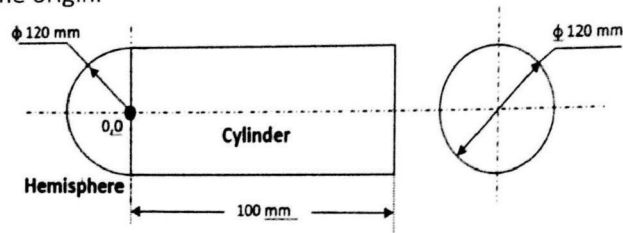

- 1 (b) Using the principle of superposition for elastically loaded members, estimate the deflection of the beam at the tip. 15

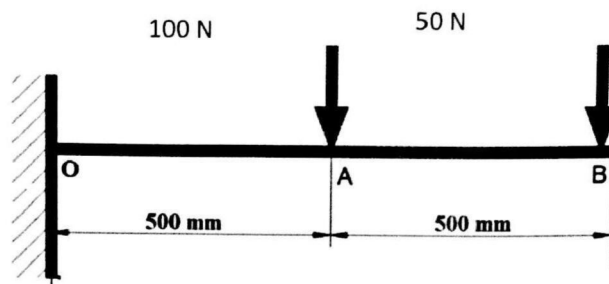

Given: $E = 2 \times 10^5 \text{ N/mm}^2$, Area moment of inertia of beam section = $10,000 \text{ mm}^4$.

- 1 (c) Determine the maximum shear stress for the member shown in figure below. The lengths and diameters of the member are: 15
 $l_1 = 500 \text{ mm}$; $l_2 = 150 \text{ mm}$; $d_1 = d_2 = 50 \text{ mm}$
 The member supports a load of 2000 N vertically downwards.
 Neglect transverse shear.

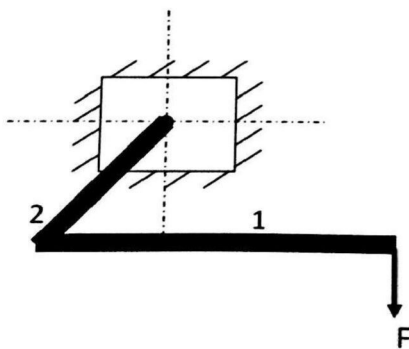

- 1 (d) Multiple equilateral triangles each of side 60 mm have to be blanked from a continuous sheet metal strip of width 60 mm with a thickness of 1.5 mm. The minimum distance between the blanks and the edges should be 4 mm. 15
 i. Sketch the blanking layout for minimizing the scrap.
 ii. Estimate the percentage of scrap for the layout.

- 2 (a) A Hexagonal Closed Packed (HCP) unit cell of Titanium has a ratio of the lattice parameter $\frac{c}{a} = 1.58$. Given the radius of Ti atoms is 0.1445 nm and atomic weight is 47.87, determine the theoretical density for a defect free structure. Given Avogadro number = 6.023×10^{23} 10

- 2 (b) The link lengths of a planar four bar linkage are: 0.2, 0.4, 0.6 and 0.6 m. Do these linkages satisfy Grashof's criteria? Draw the following inversions of the four bar linkage 10
- Crank-rocker mechanism
 - Drag-link mechanism
 - Double rocker mechanism

- 2 (c) The following data pertain to a vertical milling operation: 20

Diameter of cutter , mm	200
Dimensions of the work piece, mm	600 (L) * 30(W) * 25 (t)
Depth of cut , mm	2
Linear speed, mm/s	1
Cutter rotational speed, rpm	200
No of inserts	10
Specific cutting energy, W-s/mm ³	4

Calculate the cutting time, feed/tooth and power required.

- 2 (d) The schematic arrangement of a braking system is shown in figure below. The load weighs 50 kN and moves downward with hoist drum speed of 19.1 rpm. The hoist drum diameter is 1 m. The load must be stopped within a distance of 3 m. Determine the initial braking power. 20
Neglect the kinetic energy of rotation.

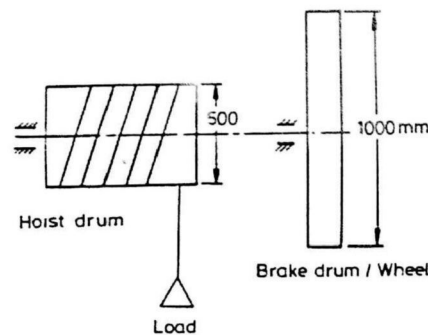

- 3 (a) A spring mass system is excited by a force of $F \sin \omega t$. At resonance, the amplitude of vibration is 12 mm. At 0.8 times the resonant frequency, the amplitude reduces to 8 mm. Determine the damping ratio of the system. 10
- 3 (b) A metric screw thread is inspected by "Two wire method". Using the data given below, determine the effective diameter of the screw thread. 10

Pitch, mm	1.25
Diameter of best wire, mm	0.722
Distance over the wire, mm	25.08

- 3 (c) A manufacturing unit uses simple exponential smoothing with $\alpha = 0.3$ to forecast demand. The forecast for the month of March is 500 units whereas the actual demand turned out to be 460 units. 20
- (i) Forecast the demand for the month of April.
 - (ii) If the actual demand for the month of April turned out to be 480, forecast the demand for May.
 - (iii) If at the end of May, all inventories are exhausted (i.e., no excess stock), estimate the revised forecast for June using the moving average method.

Note: All forecast data must be rounded to the next highest integer.

- 3 (d) Six identical bolts are used to fasten a bracket to a steel structure as shown in figure below. 20

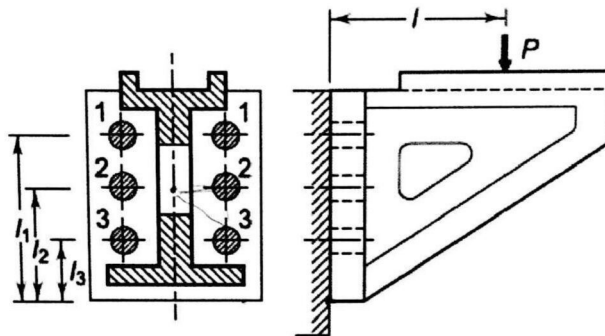

The distances are as follows:

$$l_1 = 450 \text{ mm}; \quad l_2 = 300 \text{ mm}; \quad l_3 = 150 \text{ mm}; \quad l = 400 \text{ mm}$$

The bracket supports a load of 45 kN. Neglecting transverse shear, determine the size of the bolts rounded off to the next higher standard. The permissible tensile stress in the bolt is 80 N/mm^2 .

- 4 (a) Two parallel shafts separated by a centre distance of 84 mm are to be connected by a spur gear set so that the output shaft rotates at 40% of the input shaft. If the module of the gear is 2 mm/tooth, estimate the number of teeth for the drive gear. 10
- 4 (b) A tensile test specimen made of a metallic material whose strength coefficient (K) is 900 MPa. The specimen necks at a true strain of 0.4. Calculate the ultimate tensile strength (engineering) of the material. 15
- 4 (c) A DC power source used for an arc welding process has linear characteristics with an open circuit voltage (V_0)= 60 Volts and short circuit current (I_s)= 750 A. The voltage – length characteristics can be given as $V = 15 + 6L$ where L is the arc length in mm. 15
- i. Calculate the optimum length of arc.
 - ii. Calculate the voltage and current for obtaining maximum arc power.

- 4 (d) A two link robotic arm as shown in figure below are designed to have end locator at point B about the origin O. If the lengths of the two links ($L = L_1 = L_2 = 500$) are equal, find out the end effector position (Point B) about O. 20

If an additional link of length $L = L_1/2$ is added at Point B at an angle of 45° (clockwise), find the new end effector position about Point A.

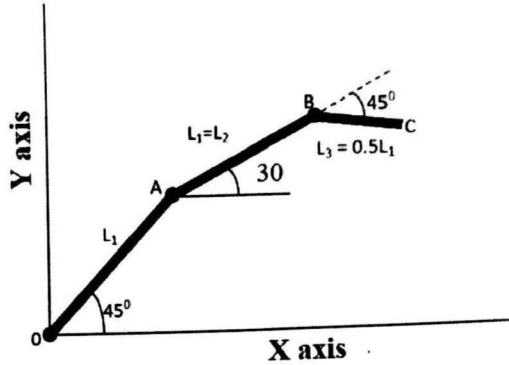

- 5 (a) A steel bar is subjected to a sequence of completely reversed stress cycles which vary over a 20 second time period as follows: 10
 Five cycles at 570 N/mm^2 , two cycles at 630 N/mm^2 and one cycle at 700 N/mm^2 .
 The corresponding lives for the above stresses are 10^5 , 3.8×10^4 and 1.6×10^4 cycles.
 The endurance limit of the steel used is 430 N/mm^2 .
 Evaluate the fatigue life of the bar for the given repeating sequence of loading.
- 5 (b) A cylinder with a height-to-diameter ratio of one solidifies in 8 minutes in a sand casting operation. What is the solidification time if the cylinder diameter is tripled for the same height? 10
- 5 (c) A strip of metal is originally 5 m long. It is stretched in 3 steps: first to a length of 6 m, then to 7 m and finally to 8 m. The original cross section area of the metal strip is 40 mm^2 . Compute the final cross section and find the percentage reduction in area due to the above stretching process. Also calculate the force required for the final stage of stretching, assuming that the true stress - true strain relation for the material is given as $\sigma = 700 \epsilon^{0.48} \text{ MPa}$. 20
- 5 (d) A cam-follower mechanism is governed by a displacement function given by 20
 $y(\theta) = 80(1 - \cos \theta)$, mm; $0 \leq \theta \leq 2\pi$
 where y is the follower displacement and θ is the cam rotation.
 The cam speed is 800 rpm. The spring constant is 22 N/mm.
 The spring has an initial compression of 10 mm when the roller follower is in its lowest position. The weight of the mass to be moved including the follower is 8 N. When the cam has rotated by 60° , determine the vertical force exerted by the cam on the follower.

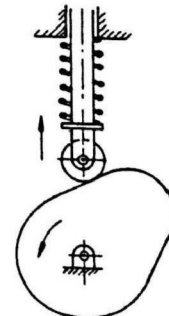

- 6 (a) During the course of an experiment, a sensor provides an output whose signal analysis leads to the following information as shown in figure. Sketch qualitatively the signal for a time period from $t = 0$ to $t = 2$ sec. Estimate the signal to noise ratio for this signal. 10

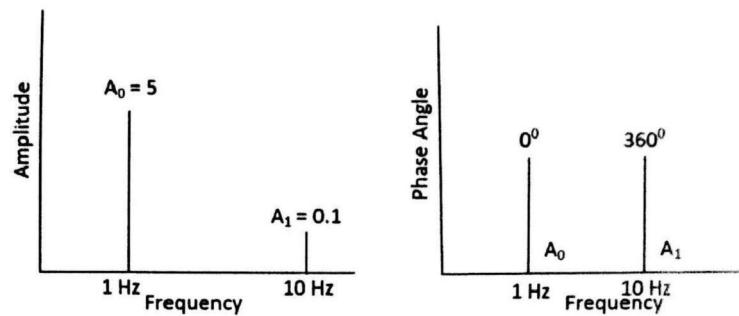

- 6 (b) Three masses of 8 kg, 12 kg and 15 kg attached at radial distances of 80 mm, 100 mm and 60 mm respectively to a disc on a shaft are in complete balance. Determine the angular positions of the masses of 12 kg and 15 kg relative to the 8 kg mass. Adopt analytical approach. 15
- 6 (c) The frontal working area of the electrode in an Electrochemical Machining (ECM) operation is 1000 mm^2 . The applied current is 900 amps and the voltage is 12 volts. The resistivity of the electrolyte is $140 \Omega\text{-mm}$. The material being cut has a valency of 4 and specific removal rate of $0.0342 \text{ mm}^3/\text{A-s}$. If the process efficiency is 90%, determine the material removal rate (MRR) and inter-electrode gap after 30 minutes of machining when the resistivity of the electrolyte has dropped to 75% of its original value. 15
- 6 (d) Consider a simply supported steel beam of span 1750 mm and diameter 40 mm. A mass of 68 kg drops from a height of 350 mm onto the beam at the mid-span. Modulus of elasticity of steel is 210 kN/mm^2 . Determine the displacement of the beam. Assume perfectly plastic collision and no weight gain on the beam due to dropping mass. 20
- 7 (a) Draw the Iron and Iron-carbon Phase diagram neatly. Identify and write the reaction equation for the (i) Eutectoid and (ii) Eutectic reactions along with the carbon percentage and associated temperature in degree celsius. 10
- 7 (b) A double acting, double ended hydraulic actuator with two end plates is to be designed to deliver a force of 100 kN. The cylinder is powered by pressurized hydraulic oil of SAE 47 grade at a pressure of 210 bar through the two end ports of the actuator. 15
- (i) Design the cylinder bore diameter assuming the rod diameter as 80 mm.
 - (ii) Estimate the flow rate (in litres per minute) requirements of the hydraulic power pack for a sustained frequency of the actuator at 10 Hz and actuator stroke length of ± 5 mm.

- 7 (c) For a planar object subjected to an arbitrary set of forces, the surface strains along the x,y directions were obtained as : 15
 $\epsilon_x = 80 \times 10^{-5} \text{ mm/mm}$,
 $\epsilon_y = 20 \times 10^{-5} \text{ mm/mm}$
 $\gamma_{xy} = 20 \times 10^{-5} \text{ radians}$
 Using Mohr's circle method, determine the principal strains and principal strain directions. If the maximum principal strain at failure is $90 \times 10^{-5} \text{ mm/mm}$, confirm if the object would fail.
- 7 (d) The torque developed by a three-crank engine is given by, 20
 $T_i = 19,000 + 7,000 \sin 3\theta \text{ N-m}$.
- The resisting torque of the machine is given by
 $T_o = 19,000 + 3,000 \sin \theta \text{ N-m}$
- where θ is the crank angle. The engine is running at a mean speed of 300 rpm and the co-efficient of speed fluctuations is limited to 0.03.
 Give a qualitative representation of the torque diagram. Determine the energy output from flywheel.
- Use the following identity:
 $\sin 3\theta = 3 \sin \theta - 4 \sin^3 \theta$
- 8 (a) A journal bearing of 50 mm diameter supports a shaft running at a speed of 320 rpm. A lubricating oil of absolute viscosity of 0.06 kg/m-s is used. The oil is found to operate satisfactorily with a diametral bearing clearance of 0.15 mm and a bearing pressure of 1.5 N/mm^2 . Consider Sommerfeld number as 14.3×10^6 , a constant. 10
- (i) If it is necessary to change the speed to 400 r.p.m, determine the pressure at which the bearing should operate.
 - (ii) If, when designed for a speed of 320 r.p.m, and pressure of 1.5 N/mm^2 , the clearance had been made 0.12 mm, what change should be made in the oil?
- 8 (b) At a Toll booth, the arrival of customer cars follows a Poisson distribution. The mean arrival rate is 10 cars/min. The service time follow an exponential probability distribution with a mean service rate of 12 cars/min. Calculate the following: 10
- i. On arrival, the number of cars expected to be waiting and being served
 - ii. Probability of no car waiting in the system
 - iii. Probability of at least 1 car waiting
 - iv. The average waiting time.
- 8 (c) A stepper motor with 200 steps is coupled to a lead screw through a reduction gear box of 10:1. The lead screw has a pitch of 5 mm. The work table driven by lead screw moves a distance of 100 mm at a feed rate of 30 mm/min. 20
- i. Identify the resolution of the work table movement assuming no transmission loss.
 - ii. Determine the required pulse rate to achieve the desired table speed.
 - iii. If the feedback for the above system control is updated after every 20 pulses and assuming there is 95% efficiency, compute the revised pulse rate for the system.

8 (d)

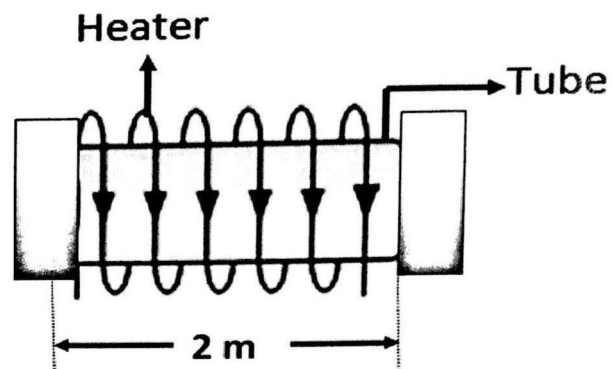

A circular tube has a length of 2 meters, outer diameter of 50 mm and a wall thickness of 1 mm. It is made of a steel whose Young's modulus is 200 GPa and coefficient of thermal expansion is $13 \times 10^{-6} / ^\circ\text{C}$. The two ends of the tube are constrained with rigid plates. The tube is heated uniformly by external heating arrangement. Estimate the temperature rise above room temperature at which the tube will buckle. Assume that the Young's modulus and coefficient of thermal expansion are constant.