

nta

Question Paper Name :	B TECH 26th Feb 2021 Shift 1
Subject Name :	B TECH
Creation Date :	2021-02-25 11:43:37
Duration :	180
Number of Questions :	90
Total Marks :	300
Display Marks:	Yes

B TECH

Group Number :	1
Group Id :	708191215
Group Maximum Duration :	0
Group Minimum Duration :	180
Show Attended Group? :	No
Edit Attended Group? :	No
Break time :	0
Group Marks :	300
Is this Group for Examiner? :	No

Physics Section A

Section Id :	708191868
Section Number :	1
Section type :	Online

Mandatory or Optional :	Mandatory
Number of Questions :	20
Number of Questions to be attempted :	20
Section Marks :	80
Mark As Answered Required? :	Yes
Sub-Section Number :	1
Sub-Section Id :	7081911148
Question Shuffling Allowed :	Yes

Question Number : 1 Question Id : 70819119924 Question Type : MCQ Option Shuffling : Yes Is

Question Mandatory : No

Correct Marks : 4 Wrong Marks : 1

In a typical combustion engine the workdone by a gas molecule is given by

$W = \alpha^2 \beta e^{\frac{-\beta x^2}{kT}}$, where x is the displacement, k is the Boltzmann constant and T is the temperature. If α and β are constants, dimensions of α will be :

Options :

70819164921. [M L T⁻²]

70819164922. [M⁰ L T⁰]

70819164923. [M L T⁻¹]

70819164924. [M² L T⁻²]

Question Number : 2 Question Id : 70819119925 Question Type : MCQ Option Shuffling : Yes Is

Question Mandatory : No

Correct Marks : 4 Wrong Marks : 1

Given below are two statements : one is labelled as Assertion A and the other is labelled as Reason R.

Assertion A : Body 'P' having mass M moving with speed 'u' has head-on collision elastically with another body 'Q' having mass 'm' initially at rest. If $m \ll M$, body 'Q' will have a maximum speed equal to '2u' after collision.

Reason R : During elastic collision, the momentum and kinetic energy are both conserved.

In the light of the above statements, choose the most appropriate answer from the options given below :

Options :

70819164925. Both A and R are correct and R is the correct explanation of A.

70819164926. Both A and R are correct but R is NOT the correct explanation of A.

70819164927. A is correct but R is not correct.

70819164928. A is not correct but R is correct.

Question Number : 3 Question Id : 70819119926 Question Type : MCQ Option Shuffling : Yes Is Question Mandatory : No

Correct Marks : 4 Wrong Marks : 1

A planet revolving in elliptical orbit has :

- A. a constant velocity of revolution.
- B. has the least velocity when it is nearest to the sun.
- C. its areal velocity is directly proportional to its velocity.
- D. areal velocity is inversely proportional to its velocity.
- E. to follow a trajectory such that the areal velocity is constant.

Choose the correct answer from the options given below :

Options :

70819164929. A only

70819164930. C only

70819164931. D only

70819164932. E only

Question Number : 4 Question Id : 70819119927 Question Type : MCQ Option Shuffling : Yes Is

Question Mandatory : No

Correct Marks : 4 Wrong Marks : 1

Find the gravitational force of attraction between the ring and sphere as shown in the diagram, where the plane of the ring is perpendicular to the line joining the centres. If $\sqrt{8}R$ is the distance between the centres of a ring (of mass 'm') and a sphere (mass 'M') where both have equal radius 'R'.

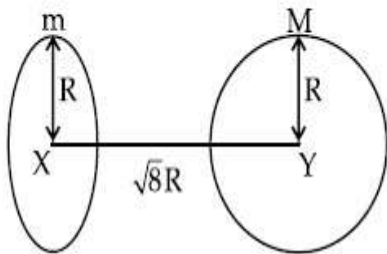

Options :

70819164933. $\frac{\sqrt{8}}{27} \cdot \frac{GmM}{R^2}$

70819164934. $\frac{\sqrt{8}}{9} \cdot \frac{GmM}{R}$

70819164935. $\frac{1}{3\sqrt{8}} \cdot \frac{GMm}{R^2}$

70819164936. $\frac{2\sqrt{2}}{3} \cdot \frac{GMm}{R^2}$

Question Number : 5 Question Id : 70819119928 Question Type : MCQ Option Shuffling : Yes Is

Question Mandatory : No

Correct Marks : 4 Wrong Marks : 1

Four identical solid spheres each of mass 'm' and radius 'a' are placed with their centres on the four corners of a square of side 'b'. The moment of inertia of the system about one side of square where the axis of rotation is parallel to the plane of the square is :

Options :

70819164937. $\frac{4}{5}ma^2 + 2mb^2$

70819164938. $\frac{8}{5}ma^2 + 2mb^2$

70819164939. $\frac{8}{5}ma^2 + mb^2$

70819164940. $\frac{4}{5}ma^2$

Question Number : 6 Question Id : 70819119929 Question Type : MCQ Option Shuffling : Yes Is

Question Mandatory : No

Correct Marks : 4 Wrong Marks : 1

A large number of water drops, each of radius r, combine to have a drop of radius R. If the surface tension is T and mechanical equivalent of heat is J, the rise in heat energy per unit volume will be :

Options :

70819164941. $\frac{2T}{J}\left(\frac{1}{r} - \frac{1}{R}\right)$

70819164942. $\frac{3T}{J}\left(\frac{1}{r} - \frac{1}{R}\right)$

70819164943. $\frac{3T}{rJ}$

70819164944.

$$\frac{2T}{rJ}$$

Question Number : 7 Question Id : 70819119930 Question Type : MCQ Option Shuffling : Yes Is

Question Mandatory : No

Correct Marks : 4 Wrong Marks : 1

The normal density of a material is ρ and its bulk modulus of elasticity is K . The magnitude of increase in density of material, when a pressure P is applied uniformly on all sides, will be :

Options :

70819164945.

$$\frac{\rho P}{K}$$

70819164946.

$$\frac{K}{\rho P}$$

70819164947.

$$\frac{\rho K}{P}$$

70819164948.

$$\frac{PK}{\rho}$$

Question Number : 8 Question Id : 70819119931 Question Type : MCQ Option Shuffling : Yes Is

Question Mandatory : No

Correct Marks : 4 Wrong Marks : 1

Assume that a tunnel is dug along a chord of the earth, at a perpendicular distance $(R/2)$ from the earth's centre, where ' R ' is the radius of the Earth. The wall of the tunnel is frictionless. If a particle is released in this tunnel, it will execute a simple harmonic motion with a time period :

Options :

70819164949.

$$\frac{2\pi R}{g}$$

70819164950.

$$2\pi \sqrt{\frac{R}{g}}$$

70819164951.

$$\frac{1}{2\pi} \sqrt{\frac{g}{R}}$$

70819164952.

$$\frac{g}{2\pi R}$$

Question Number : 9 Question Id : 70819119932 Question Type : MCQ Option Shuffling : Yes Is

Question Mandatory : No

Correct Marks : 4 Wrong Marks : 1

The temperature θ at the junction of two insulating sheets, having thermal resistances R_1 and R_2 as well as top and bottom temperatures θ_1 and θ_2 (as shown in figure) is given by :

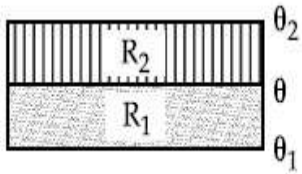

Options :

70819164953.

$$\frac{\theta_1 R_2 + \theta_2 R_1}{R_1 + R_2}$$

70819164954.

$$\frac{\theta_1 R_1 + \theta_2 R_2}{R_1 + R_2}$$

70819164955.

$$\frac{\theta_1 R_2 - \theta_2 R_1}{R_2 - R_1}$$

70819164956.

$$\frac{\theta_2 R_2 - \theta_1 R_1}{R_2 - R_1}$$

Question Number : 10 Question Id : 70819119933 Question Type : MCQ Option Shuffling : Yes

Is Question Mandatory : No

Correct Marks : 4 Wrong Marks : 1

A particle is moving with uniform speed along the circumference of a circle of radius R under the action of a central fictitious force F which is inversely proportional to R^3 . Its time period of revolution will be given by :

Options :

70819164957. $T \propto R^{\frac{3}{2}}$

70819164958. $T \propto R^{\frac{4}{3}}$

70819164959. $T \propto R^2$

70819164960. $T \propto R^{\frac{5}{2}}$

Question Number : 11 Question Id : 70819119934 Question Type : MCQ Option Shuffling : Yes

Is Question Mandatory : No

Correct Marks : 4 Wrong Marks : 1

If two similar springs each of spring constant K_1 are joined in series, the new spring constant and time period would be changed by a factor :

Options :

70819164961. $\frac{1}{2}, \sqrt{2}$

70819164962. $\frac{1}{4}, 2\sqrt{2}$

70819164963. $\frac{1}{2}, 2\sqrt{2}$

70819164964. $\frac{1}{4}, \sqrt{2}$

Question Number : 12 Question Id : 70819119935 Question Type : MCQ Option Shuffling : Yes

Is Question Mandatory : No

Correct Marks : 4 Wrong Marks : 1

Find the electric field at point P (as shown in figure) on the perpendicular bisector of a uniformly charged thin wire of length L carrying a charge Q. The distance of the point P

from the centre of the rod is $a = \frac{\sqrt{3}}{2} L$.

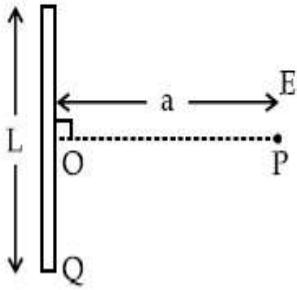

Options :

70819164965. $\frac{Q}{3\pi\epsilon_0 L^2}$

70819164966. $\frac{Q}{4\pi\epsilon_0 L^2}$

70819164967. $\frac{\sqrt{3}Q}{4\pi\epsilon_0 L^2}$

70819164968. $\frac{Q}{2\sqrt{3}\pi\epsilon_0 L^2}$

Question Number : 13 Question Id : 70819119936 Question Type : MCQ Option Shuffling : Yes

Is Question Mandatory : No

Correct Marks : 4 Wrong Marks : 1

Consider the combination of 2 capacitors C_1 and C_2 , with $C_2 > C_1$, when connected in parallel, the equivalent capacitance is $\frac{15}{4}$ times the equivalent capacitance of the same connected in series. Calculate the ratio of capacitors, $\frac{C_2}{C_1}$.

Options :

70819164969. $\frac{29}{15}$

70819164970. $\frac{15}{11}$

70819164971. $\frac{15}{4}$

70819164972. $\frac{111}{80}$

Question Number : 14 Question Id : 70819119937 Question Type : MCQ Option Shuffling : Yes

Is Question Mandatory : No

Correct Marks : 4 Wrong Marks : 1

An alternating current is given by the equation $i = i_1 \sin \omega t + i_2 \cos \omega t$. The rms current will be :

Options :

70819164973. $\frac{1}{\sqrt{2}} (i_1 + i_2)$

70819164974. $\frac{1}{\sqrt{2}} (i_1 + i_2)^2$

70819164975. $\frac{1}{\sqrt{2}} (i_1^2 + i_2^2)^{\frac{1}{2}}$

70819164976. $\frac{1}{2} (i_1^2 + i_2^2)^{\frac{1}{2}}$

**Question Number : 15 Question Id : 70819119938 Question Type : MCQ Option Shuffling : Yes
Is Question Mandatory : No**

Correct Marks : 4 Wrong Marks : 1

Five equal resistances are connected in a network as shown in figure. The net resistance between the points A and B is :

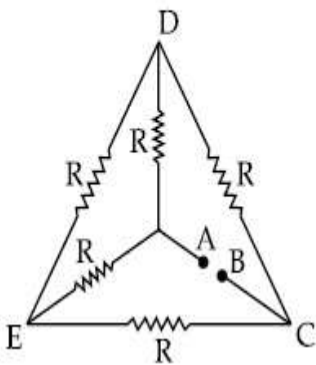

Options :

70819164977. $2R$

70819164978. $\frac{R}{2}$

70819164979. R

70819164980. $\frac{3R}{2}$

**Question Number : 16 Question Id : 70819119939 Question Type : MCQ Option Shuffling : Yes
Is Question Mandatory : No**

Correct Marks : 4 Wrong Marks : 1

A short straight object of height 100 cm lies before the central axis of a spherical mirror whose focal length has absolute value $|f| = 40$ cm. The image of object produced by the mirror is of height 25 cm and has the same orientation of the object. One may conclude from the information :

Options :

70819164981. Image is virtual, opposite side of concave mirror.

70819164982. Image is real, same side of concave mirror.

70819164983. Image is virtual, opposite side of convex mirror.

70819164984. Image is real, same side of convex mirror.

Question Number : 17 Question Id : 70819119940 Question Type : MCQ Option Shuffling : Yes

Is Question Mandatory : No

Correct Marks : 4 Wrong Marks : 1

In a Young's double slit experiment two slits are separated by 2 mm and the screen is placed one meter away. When a light of wavelength 500 nm is used, the fringe separation will be :

Options :

70819164985. 1 mm

70819164986. 0.75 mm

70819164987. 0.50 mm

70819164988. 0.25 mm

Question Number : 18 Question Id : 70819119941 Question Type : MCQ Option Shuffling : Yes

Is Question Mandatory : No

Correct Marks : 4 Wrong Marks : 1

Given below are two statements : one is labelled as Assertion A and the other is labelled as Reason R.

Assertion A : An electron microscope can achieve better resolving power than an optical microscope.

Reason R : The de Broglie's wavelength of the electrons emitted from an electron gun is much less than wavelength of visible light.

In the light of the above statements, choose the correct answer from the options given below :

Options :

70819164989. Both A and R are true and R is the correct explanation of A.

70819164990. Both A and R are true but R is NOT the correct explanation of A.

70819164991. A is true but R is false.

70819164992. A is false but R is true.

Question Number : 19 Question Id : 70819119942 Question Type : MCQ Option Shuffling : Yes

Is Question Mandatory : No

Correct Marks : 4 Wrong Marks : 1

If λ_1 and λ_2 are the wavelengths of the third member of Lyman and first member of the Paschen series respectively, then the value of $\lambda_1 : \lambda_2$ is :

Options :

70819164993. 7 : 108

70819164994. 7 : 135

70819164995. 1 : 3

70819164996. 1 : 9

Question Number : 20 Question Id : 70819119943 Question Type : MCQ Option Shuffling : Yes

Is Question Mandatory : No

Correct Marks : 4 Wrong Marks : 1

LED is constructed from Ga-As-P semiconducting material. The energy gap of this LED is 1.9 eV. Calculate the wavelength of light emitted and its colour.

[$h = 6.63 \times 10^{-34}$ Js and $c = 3 \times 10^8$ ms⁻¹]

Options :

70819164997. 654 nm and red colour

70819164998. 654 nm and orange colour

70819164999. 1046 nm and blue colour

70819165000. 1046 nm and red colour

Physics Section B

Section Id :	708191869
Section Number :	2
Section type :	Online
Mandatory or Optional :	Mandatory
Number of Questions :	10
Number of Questions to be attempted :	5
Section Marks :	20
Mark As Answered Required? :	Yes
Sub-Section Number :	1
Sub-Section Id :	7081911149
Question Shuffling Allowed :	Yes

Question Number : 21 Question Id : 70819119944 Question Type : SA

Correct Marks : 4 Wrong Marks : 0

As shown in the figure, a block of mass $\sqrt{3}$ kg is kept on a horizontal rough surface of coefficient of friction $\frac{1}{3\sqrt{3}}$. The critical force to be applied on the vertical surface as shown at an angle 60° with horizontal such that it does not move, will be $3x$. The value of x will be _____.

$$[g = 10 \text{ m/s}^2; \sin 60^\circ = \frac{\sqrt{3}}{2}; \cos 60^\circ = \frac{1}{2}]$$

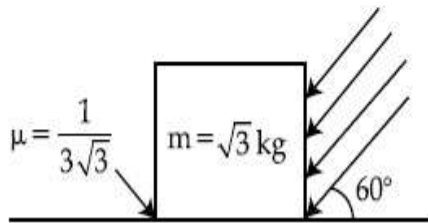

Response Type : Numeric

Evaluation Required For SA : Yes

Show Word Count : Yes

Answers Type : Range

Text Areas : PlainText

Possible Answers :

5 to 5.001

Question Number : 22 **Question Id :** 70819119945 **Question Type :** SA

Correct Marks : 4 **Wrong Marks :** 0

A boy pushes a box of mass 2 kg with a force $\vec{F} = (20\hat{i} + 10\hat{j}) \text{ N}$ on a frictionless surface.

If the box was initially at rest, then _____ m is displacement along the x -axis after 10 s.

Response Type : Numeric

Evaluation Required For SA : Yes

Show Word Count : Yes

Answers Type : Range

Text Areas : PlainText

Possible Answers :

5 to 5.001

Question Number : 23 Question Id : 70819119946 Question Type : SA

Correct Marks : 4 Wrong Marks : 0

A person standing on a spring balance inside a stationary lift measures 60 kg. The weight of that person if the lift descends with uniform downward acceleration of 1.8 m/s^2 will be _____ N. [$g = 10 \text{ m/s}^2$]

Response Type : Numeric

Evaluation Required For SA : Yes

Show Word Count : Yes

Answers Type : Range

Text Areas : PlainText

Possible Answers :

5 to 5.001

Question Number : 24 Question Id : 70819119947 Question Type : SA

Correct Marks : 4 Wrong Marks : 0

The mass per unit length of a uniform wire is 0.135 g/cm . A transverse wave of the form $y = -0.21 \sin(x + 30t)$ is produced in it, where x is in meter and t is in second. Then, the expected value of tension in the wire is $x \times 10^{-2} \text{ N}$. Value of x is _____. (Round-off to the nearest integer)

Response Type : Numeric

Evaluation Required For SA : Yes

Show Word Count : Yes

Answers Type : Range

Text Areas : PlainText

Possible Answers :

5 to 5.001

Question Number : 25 Question Id : 70819119948 Question Type : SA

Correct Marks : 4 Wrong Marks : 0

A container is divided into two chambers by a partition. The volume of first chamber is 4.5 litre and second chamber is 5.5 litre. The first chamber contain 3.0 moles of gas at pressure 2.0 atm and second chamber contain 4.0 moles of gas at pressure 3.0 atm. After the partition is removed and the mixture attains equilibrium, then, the common equilibrium pressure existing in the mixture is $x \times 10^{-1}$ atm. Value of x is _____.

Response Type : Numeric

Evaluation Required For SA : Yes

Show Word Count : Yes

Answers Type : Range

Text Areas : PlainText

Possible Answers :

5 to 5.001

Question Number : 26 Question Id : 70819119949 Question Type : SA

Correct Marks : 4 Wrong Marks : 0

A radiation is emitted by 1000 W bulb and it generates an electric field and magnetic field at P, placed at a distance of 2 m. The efficiency of the bulb is 1.25%. The value of peak electric field at P is $x \times 10^{-1}$ V/m. Value of x is _____. (Rounded-off to the nearest integer)

[Take $\epsilon_0 = 8.85 \times 10^{-12} \text{ C}^2 \text{ N}^{-1} \text{ m}^{-2}$, $c = 3 \times 10^8 \text{ ms}^{-1}$]

Response Type : Numeric

Evaluation Required For SA : Yes

Show Word Count : Yes

Answers Type : Range

Text Areas : PlainText

Possible Answers :

5 to 5.001

Question Number : 27 Question Id : 70819119950 Question Type : SA

Correct Marks : 4 Wrong Marks : 0

In an electrical circuit, a battery is connected to pass 20 C of charge through it in a certain given time. The potential difference between two plates of the battery is maintained at 15 V. The workdone by the battery is _____ J.

Response Type : Numeric

Evaluation Required For SA : Yes

Show Word Count : Yes

Answers Type : Range

Text Areas : PlainText

Possible Answers :

5 to 5.001

Question Number : 28 **Question Id :** 70819119951 **Question Type :** SA

Correct Marks : 4 **Wrong Marks :** 0

The circuit contains two diodes each with a forward resistance of $50\ \Omega$ and with infinite reverse resistance. If the battery voltage is $6\ \text{V}$, the current through the $120\ \Omega$ resistance is _____ mA.

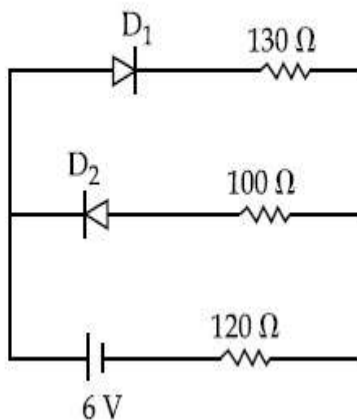

Response Type : Numeric

Evaluation Required For SA : Yes

Show Word Count : Yes

Answers Type : Range

Text Areas : PlainText

Possible Answers :

5 to 5.001

Question Number : 29 **Question Id :** 70819119952 **Question Type :** SA

Correct Marks : 4 **Wrong Marks :** 0

The maximum and minimum amplitude of an amplitude modulated wave is $16\ \text{V}$ and $8\ \text{V}$ respectively. The modulation index for this amplitude modulated wave is $x \times 10^{-2}$. The value of x is _____.

Response Type : Numeric

Evaluation Required For SA : Yes

Show Word Count : Yes

Answers Type : Range

Text Areas : PlainText

Possible Answers :

5 to 5.001

Question Number : 30 **Question Id :** 70819119953 **Question Type :** SA

Correct Marks : 4 **Wrong Marks :** 0

In a series LCR resonant circuit, the quality factor is measured as 100. If the inductance is increased by two fold and resistance is decreased by two fold, then the quality factor after this change will be _____.

Response Type : Numeric

Evaluation Required For SA : Yes

Show Word Count : Yes

Answers Type : Range

Text Areas : PlainText

Possible Answers :

5 to 5.001

Chemistry Section A

Section Id :	708191870
Section Number :	3
Section type :	Online
Mandatory or Optional :	Mandatory
Number of Questions :	20
Number of Questions to be attempted :	20
Section Marks :	80

Mark As Answered Required? : Yes
Sub-Section Number : 1
Sub-Section Id : 7081911150
Question Shuffling Allowed : Yes

Question Number : 31 Question Id : 70819119954 Question Type : MCQ Option Shuffling : Yes
Is Question Mandatory : No

Correct Marks : 4 Wrong Marks : 1

The orbital having two radial as well as two angular nodes is :

Options :

70819165011. 3p

70819165012. 4d

70819165013. 4f

70819165014. 5d

Question Number : 32 Question Id : 70819119955 Question Type : MCQ Option Shuffling : Yes
Is Question Mandatory : No

Correct Marks : 4 Wrong Marks : 1

Given below are two statements : one is labelled as Assertion A and the other is labelled as Reason R.

Assertion A : Dipole-dipole interactions are the only non-covalent interactions, resulting in hydrogen bond formation.

Reason R : Fluorine is the most electronegative element and hydrogen bonds in HF are symmetrical.

In the light of the above statements, choose the most appropriate answer from the options given below :

Options :

70819165015. Both A and R are true and R is the correct explanation of A

70819165016. Both A and R are true but R is NOT the correct explanation of A

70819165017. A is true but R is false

70819165018. A is false but R is true

Question Number : 33 Question Id : 70819119956 Question Type : MCQ Option Shuffling : Yes

Is Question Mandatory : No

Correct Marks : 4 Wrong Marks : 1

Match List-I with List-II.

List-I	List-II
Electronic configuration of elements	$\Delta_f H$ in kJ mol^{-1}
(a) $1s^2 2s^2$	(i) 801
(b) $1s^2 2s^2 2p^4$	(ii) 899
(c) $1s^2 2s^2 2p^3$	(iii) 1314
(d) $1s^2 2s^2 2p^1$	(iv) 1402

Choose the most appropriate answer from the options given below :

Options :

70819165019. (a) \rightarrow (i), (b) \rightarrow (iv), (c) \rightarrow (iii), (d) \rightarrow (ii)

70819165020. (a) \rightarrow (iv), (b) \rightarrow (i), (c) \rightarrow (ii), (d) \rightarrow (iii)

70819165021. (a) \rightarrow (ii), (b) \rightarrow (iii), (c) \rightarrow (iv), (d) \rightarrow (i)

70819165022. (a) \rightarrow (i), (b) \rightarrow (iii), (c) \rightarrow (iv), (d) \rightarrow (ii)

Question Number : 34 Question Id : 70819119957 Question Type : MCQ Option Shuffling : Yes

Is Question Mandatory : No

Correct Marks : 4 Wrong Marks : 1

Match List-I with List-II.

List-I (Ore)	List-II (Element Present)
(a) Kernite	(i) Tin
(b) Cassiterite	(ii) Boron
(c) Calamine	(iii) Fluorine
(d) Cryolite	(iv) Zinc

Choose the most appropriate answer from the options given below :

Options :

70819165023. (a) → (ii), (b) → (i), (c) → (iv), (d) → (iii)

70819165024. (a) → (iii), (b) → (i), (c) → (ii), (d) → (iv)

70819165025. (a) → (ii), (b) → (iv), (c) → (i), (d) → (iii)

70819165026. (a) → (i), (b) → (iii), (c) → (iv), (d) → (ii)

Question Number : 35 Question Id : 70819119958 Question Type : MCQ Option Shuffling : Yes

Is Question Mandatory : No

Correct Marks : 4 Wrong Marks : 1

Statements about heavy water are given below.

- A. Heavy water is used in exchange reactions for the study of reaction mechanisms.
- B. Heavy water is prepared by exhaustive electrolysis of water.
- C. Heavy water has higher boiling point than ordinary water.
- D. Viscosity of H_2O is greater than D_2O .

Choose the most appropriate answer from the options given below :

Options :

70819165027. A and B only

70819165028. A and C only

70819165029. A and D only

70819165030. A, B and C only

Question Number : 36 Question Id : 70819119959 Question Type : MCQ Option Shuffling : Yes

Is Question Mandatory : No

Correct Marks : 4 Wrong Marks : 1

Find A, B and C in the following reactions :

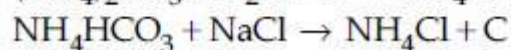
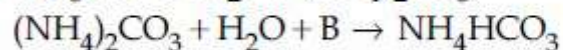
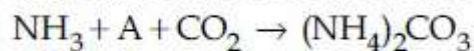

Options :

70819165031. A – H₂O ; B – O₂ ; C – Na₂CO₃

70819165032. A – H₂O ; B – O₂ ; C – NaHCO₃

70819165033. A – H₂O ; B – CO₂ ; C – NaHCO₃

70819165034. A – O₂ ; B – CO₂ ; C – Na₂CO₃

Question Number : 37 Question Id : 70819119960 Question Type : MCQ Option Shuffling : Yes

Is Question Mandatory : No

Correct Marks : 4 Wrong Marks : 1

Compound A used as a strong oxidizing agent is amphoteric in nature. It is the part of lead storage batteries. Compound A is :

Options :

70819165035. PbO

70819165036. PbO₂

70819165037. Pb₃O₄

70819165038. PbSO_4

**Question Number : 38 Question Id : 70819119961 Question Type : MCQ Option Shuffling : Yes
Is Question Mandatory : No**

Correct Marks : 4 Wrong Marks : 1

Which one of the following lanthanoids does not form MO_2 ?
[M is lanthanoid metal]

Options :

70819165039. Nd

70819165040. Dy

70819165041. Pr

70819165042. Yb

**Question Number : 39 Question Id : 70819119962 Question Type : MCQ Option Shuffling : Yes
Is Question Mandatory : No**

Correct Marks : 4 Wrong Marks : 1

The presence of ozone in troposphere :

Options :

70819165043. protects us from the UV radiation

70819165044. protects us from the X-ray radiation

70819165045. generates photochemical smog

70819165046. protects us from greenhouse effect

Question Number : 40 Question Id : 70819119963 Question Type : MCQ Option Shuffling : Yes

Is Question Mandatory : No

Correct Marks : 4 Wrong Marks : 1

Given below are two statements :

Statement I : A mixture of chloroform and aniline can be separated by simple distillation.

Statement II : When separating aniline from a mixture of aniline and water by steam distillation aniline boils below its boiling point.

In the light of the above statements, choose the most appropriate answer from the options given below :

Options :

70819165047. Both Statement I and Statement II are true

70819165048. Both Statement I and Statement II are false

70819165049. Statement I is true but Statement II is false

70819165050. Statement I is false but Statement II is true

Question Number : 41 Question Id : 70819119964 Question Type : MCQ Option Shuffling : Yes

Is Question Mandatory : No

Correct Marks : 4 Wrong Marks : 1

Which of the following is 'a' FALSE statement ?

Options :

70819165051. Carius tube is used in the estimation of sulphur in an organic compound.

70819165052. Carius method is used for the estimation of nitrogen in an organic compound.

70819165053. Kjeldahl's method is used for the estimation of nitrogen in an organic compound.

Phosphoric acid produced on oxidation of phosphorus present in an organic compound is precipitated as $Mg_2P_2O_7$ by adding magnesia mixture.

70819165054.

Question Number : 42 Question Id : 70819119965 Question Type : MCQ Option Shuffling : Yes

Is Question Mandatory : No

Correct Marks : 4 Wrong Marks : 1

For the given reaction :

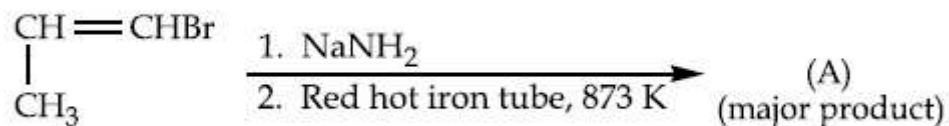

What is 'A' ?

Options :

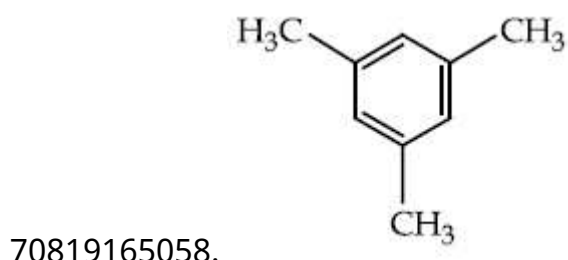
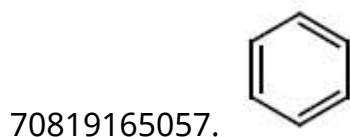
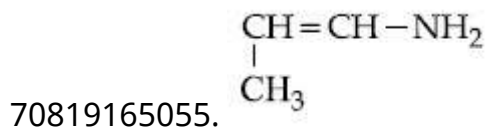

Question Number : 43 Question Id : 70819119966 Question Type : MCQ Option Shuffling : Yes

Is Question Mandatory : No

Correct Marks : 4 Wrong Marks : 1

For the given reaction :

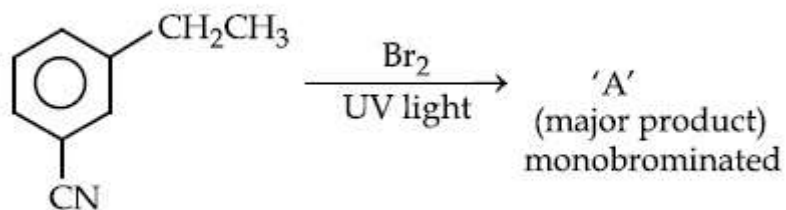

What is 'A'?

Options :

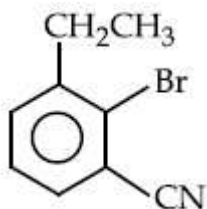

70819165059.



70819165060.

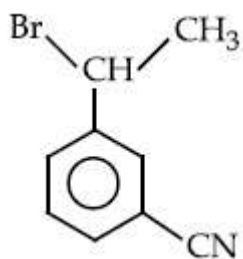

70819165061.

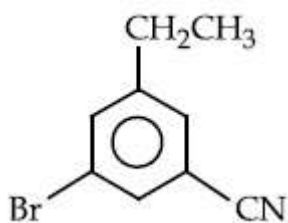

70819165062.

Question Number : 44 Question Id : 70819119967 Question Type : MCQ Option Shuffling : Yes

Is Question Mandatory : No

Correct Marks : 4 Wrong Marks : 1

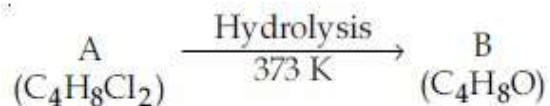

B reacts with Hydroxyl amine but does not give Tollen's test. Identify A and B.

Options :

70819165063. 1,1-Dichlorobutane and Butanal
70819165064. 2,2-Dichlorobutane and Butanal
70819165065. 1,1-Dichlorobutane and 2-Butanone
70819165066. 2,2-Dichlorobutane and Butan-2-one

Question Number : 45 Question Id : 70819119968 Question Type : MCQ Option Shuffling : Yes

Is Question Mandatory : No

Correct Marks : 4 Wrong Marks : 1

Identify the major products A and B respectively in the following reactions of phenol :

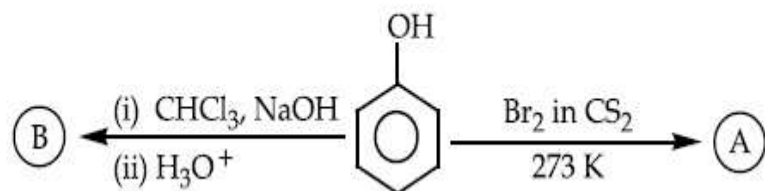

Options :

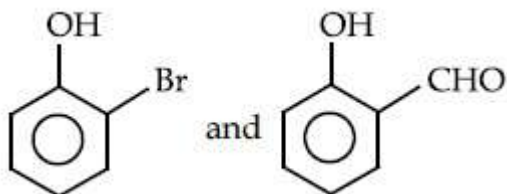

70819165067.

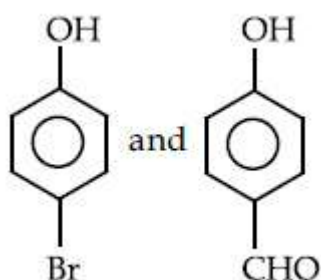

70819165068.

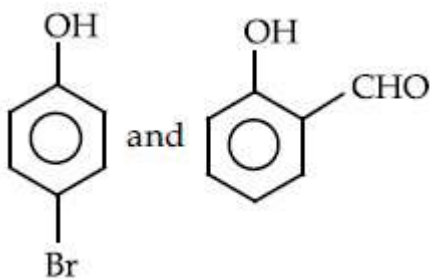
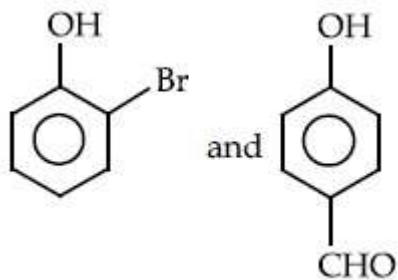

**Question Number : 46 Question Id : 70819119969 Question Type : MCQ Option Shuffling : Yes
Is Question Mandatory : No**

Correct Marks : 4 Wrong Marks : 1

Given below are two statements :

Statement I : *o*-Nitrophenol is steam volatile due to intramolecular hydrogen bonding.

Statement II : *o*-Nitrophenol has high melting due to hydrogen bonding.

In the light of the above statements, choose the most appropriate answer from the options given below :

Options :

70819165071. Both Statement I and Statement II are true

70819165072. Both Statement I and Statement II are false

70819165073. Statement I is true but Statement II is false

70819165074. Statement I is false but Statement II is true

Question Number : 47 Question Id : 70819119970 Question Type : MCQ Option Shuffling : Yes

Is Question Mandatory : No

Correct Marks : 4 Wrong Marks : 1

An amine on reaction with benzenesulphonyl chloride produces a compound insoluble in alkaline solution. This amine can be prepared by ammonolysis of ethyl chloride. The correct structure of amine is :

Options :

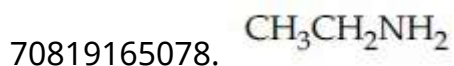
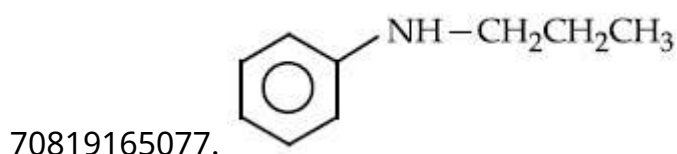
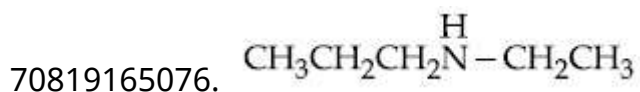
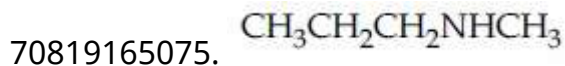

Question Number : 48 Question Id : 70819119971 Question Type : MCQ Option Shuffling : Yes

Is Question Mandatory : No

Correct Marks : 4 Wrong Marks : 1

The structure of Neoprene is :

Options :

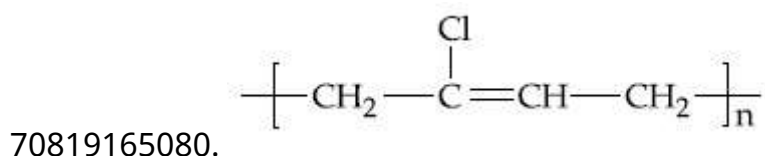
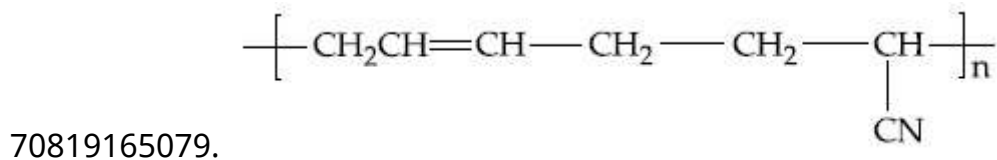

70819165081.

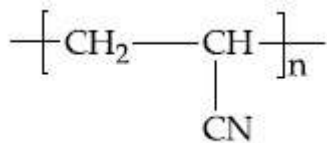
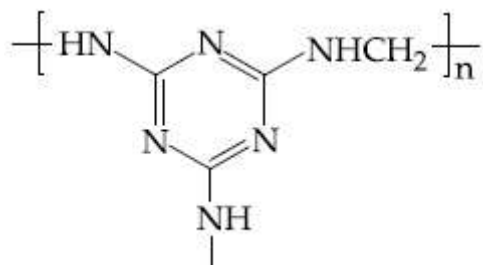

70819165082.

Question Number : 49 Question Id : 70819119972 Question Type : MCQ Option Shuffling : Yes Is Question Mandatory : No

Correct Marks : 4 Wrong Marks : 1

Which of the following vitamin is helpful in delaying the blood clotting ?

Options :

70819165083. Vitamin B

70819165084. Vitamin C

70819165085. Vitamin E

70819165086. Vitamin K

Question Number : 50 Question Id : 70819119973 Question Type : MCQ Option Shuffling : Yes Is Question Mandatory : No

Correct Marks : 4 Wrong Marks : 1

On treating a compound with warm dil. H_2SO_4 , gas X is evolved which turns $\text{K}_2\text{Cr}_2\text{O}_7$ paper acidified with dil. H_2SO_4 to a green compound Y. X and Y respectively are :

Options :

70819165087. $\text{X} = \text{SO}_3, \text{Y} = \text{Cr}_2(\text{SO}_4)_3$

70819165088. $X = \text{SO}_2$, $Y = \text{Cr}_2\text{O}_3$

70819165089. $X = \text{SO}_3$, $Y = \text{Cr}_2\text{O}_3$

70819165090. $X = \text{SO}_2$, $Y = \text{Cr}_2(\text{SO}_4)_3$

Chemistry Section B

Section Id :	708191871
Section Number :	4
Section type :	Online
Mandatory or Optional :	Mandatory
Number of Questions :	10
Number of Questions to be attempted :	5
Section Marks :	20
Mark As Answered Required? :	Yes
Sub-Section Number :	1
Sub-Section Id :	7081911151
Question Shuffling Allowed :	Yes

Question Number : 51 Question Id : 70819119974 Question Type : SA

Correct Marks : 4 Wrong Marks : 0

The number of significant figures in 50000.020×10^{-3} is _____.

Response Type : Numeric

Evaluation Required For SA : Yes

Show Word Count : Yes

Answers Type : Range

Text Areas : PlainText

Possible Answers :

5 to 5.001

Question Number : 52 Question Id : 70819119975 Question Type : SA

Correct Marks : 4 Wrong Marks : 0

A certain gas obeys $P(V_m - b) = RT$. The value of $\left(\frac{\partial Z}{\partial P}\right)_T$ is $\frac{xb}{RT}$. The value of x is _____.

(Integer answer) (Z : compressibility factor)

Response Type : Numeric

Evaluation Required For SA : Yes

Show Word Count : Yes

Answers Type : Range

Text Areas : PlainText

Possible Answers :

5 to 5.001

Question Number : 53 Question Id : 70819119976 Question Type : SA

Correct Marks : 4 Wrong Marks : 0

For a chemical reaction $A + B \rightleftharpoons C + D$

($\Delta_r H^\ominus = 80 \text{ kJ mol}^{-1}$) the entropy change $\Delta_r S^\ominus$ depends on the temperature T(in K) as $\Delta_r S^\ominus = 2T \text{ (J K}^{-1}\text{mol}^{-1}\text{)}$.

Minimum temperature at which it will become spontaneous is _____ K. (Integer)

Response Type : Numeric

Evaluation Required For SA : Yes

Show Word Count : Yes

Answers Type : Range

Text Areas : PlainText

Possible Answers :

5 to 5.001

Question Number : 54 Question Id : 70819119977 Question Type : SA

Correct Marks : 4 Wrong Marks : 0

224 mL of $\text{SO}_{2(g)}$ at 298 K and 1 atm is passed through 100 mL of 0.1 M NaOH solution. The non-volatile solute produced is dissolved in 36 g of water. The lowering of vapour pressure of solution (assuming the solution is dilute) ($P_{(\text{H}_2\text{O})}^\circ = 24 \text{ mm of Hg}$) is $x \times 10^{-2}$ mm of Hg, the value of x is _____. (Integer answer)

Response Type : Numeric

Evaluation Required For SA : Yes

Show Word Count : Yes

Answers Type : Range

Text Areas : PlainText

Possible Answers :

5 to 5.001

Question Number : 55 Question Id : 70819119978 Question Type : SA

Correct Marks : 4 Wrong Marks : 0

A homogeneous ideal gaseous reaction $\text{AB}_{2(g)} = \text{A}_{(g)} + 2\text{B}_{(g)}$ is carried out in a 25 litre flask at 27°C. The initial amount of AB_2 was 1 mole and the equilibrium pressure was 1.9 atm. The value of K_p is $x \times 10^{-2}$. The value of x is _____. (Integer answer)
[$R = 0.08206 \text{ dm}^3\text{atm K}^{-1} \text{ mol}^{-1}$]

Response Type : Numeric

Evaluation Required For SA : Yes

Show Word Count : Yes

Answers Type : Range

Text Areas : PlainText

Possible Answers :

5 to 5.001

Question Number : 56 Question Id : 70819119979 Question Type : SA

Correct Marks : 4 Wrong Marks : 0

Consider the following reaction



The quantity of electricity required in Faraday to reduce five moles of MnO_4^- is _____.
(Integer answer)

Response Type : Numeric

Evaluation Required For SA : Yes

Show Word Count : Yes

Answers Type : Range

Text Areas : PlainText

Possible Answers :

5 to 5.001

Question Number : 57 **Question Id :** 70819119980 **Question Type :** SA

Correct Marks : 4 **Wrong Marks :** 0

An exothermic reaction $X \rightarrow Y$ has an activation energy 30 kJ mol^{-1} . If energy change ΔE during the reaction is -20 kJ , then the activation energy for the reverse reaction in kJ is _____. (Integer answer)

Response Type : Numeric

Evaluation Required For SA : Yes

Show Word Count : Yes

Answers Type : Range

Text Areas : PlainText

Possible Answers :

5 to 5.001

Question Number : 58 **Question Id :** 70819119981 **Question Type :** SA

Correct Marks : 4 **Wrong Marks :** 0

3.12 g of oxygen is adsorbed on 1.2 g of platinum metal. The volume of oxygen adsorbed per gram of the adsorbent at 1 atm and 300 K in L is _____.

[$R = 0.0821 \text{ L atm K}^{-1} \text{ mol}^{-1}$]

Response Type : Numeric

Evaluation Required For SA : Yes

Show Word Count : Yes

Answers Type : Range

Text Areas : PlainText

Possible Answers :

5 to 5.001

Question Number : 59 **Question Id :** 70819119982 **Question Type :** SA

Correct Marks : 4 **Wrong Marks :** 0

Dichromate ion is treated with base, the oxidation number of Cr in the product formed is _____.

Response Type : Numeric

Evaluation Required For SA : Yes

Show Word Count : Yes

Answers Type : Range

Text Areas : PlainText

Possible Answers :

5 to 5.001

Question Number : 60 **Question Id :** 70819119983 **Question Type :** SA

Correct Marks : 4 **Wrong Marks :** 0

Number of bridging CO ligands in $[\text{Mn}_2(\text{CO})_{10}]$ is _____.

Response Type : Numeric

Evaluation Required For SA : Yes

Show Word Count : Yes

Answers Type : Range

Text Areas : PlainText

Possible Answers :

5 to 5.001

Mathematics Section A

Section Id :	708191872
Section Number :	5
Section type :	Online
Mandatory or Optional :	Mandatory
Number of Questions :	20
Number of Questions to be attempted :	20
Section Marks :	80
Mark As Answered Required? :	Yes
Sub-Section Number :	1
Sub-Section Id :	7081911152
Question Shuffling Allowed :	Yes

Question Number : 61 Question Id : 70819119984 Question Type : MCQ Option Shuffling : Yes
Is Question Mandatory : No

Correct Marks : 4 Wrong Marks : 1

If \vec{a} and \vec{b} are perpendicular, then $\vec{a} \times (\vec{a} \times (\vec{a} \times (\vec{a} \times \vec{b})))$ is equal to :

Options :

70819165101. $\vec{0}$

70819165102. $\frac{1}{2} |\vec{a}|^4 \vec{b}$

70819165103. $|\vec{a}|^4 \vec{b}$

70819165104. $\vec{a} \times \vec{b}$

Question Number : 62 Question Id : 70819119985 Question Type : MCQ Option Shuffling : Yes

Is Question Mandatory : No

Correct Marks : 4 Wrong Marks : 1

If $(1, 5, 35)$, $(7, 5, 5)$, $(1, \lambda, 7)$ and $(2\lambda, 1, 2)$ are coplanar, then the sum of all possible values of λ is :

Options :

70819165105. $\frac{39}{5}$

70819165106. $-\frac{39}{5}$

70819165107. $-\frac{44}{5}$

70819165108. $\frac{44}{5}$

Question Number : 63 Question Id : 70819119986 Question Type : MCQ Option Shuffling : Yes

Is Question Mandatory : No

Correct Marks : 4 Wrong Marks : 1

The intersection of three lines $x - y = 0$, $x + 2y = 3$ and $2x + y = 6$ is a :

Options :

70819165109. Right angled triangle

70819165110. Isosceles triangle

70819165111. Equilateral triangle

70819165112. None of the above

Question Number : 64 Question Id : 70819119987 Question Type : MCQ Option Shuffling : Yes

Is Question Mandatory : No

Correct Marks : 4 Wrong Marks : 1

The value of $\begin{vmatrix} (a+1)(a+2) & a+2 & 1 \\ (a+2)(a+3) & a+3 & 1 \\ (a+3)(a+4) & a+4 & 1 \end{vmatrix}$ is :

Options :

70819165113. $(a+1)(a+2)(a+3)$

70819165114. $(a+2)(a+3)(a+4)$

70819165115. -2

70819165116. 0

Question Number : 65 Question Id : 70819119988 Question Type : MCQ Option Shuffling : Yes

Is Question Mandatory : No

Correct Marks : 4 Wrong Marks : 1

The rate of growth of bacteria in a culture is proportional to the number of bacteria present and the bacteria count is 1000 at initial time $t=0$. The number of bacteria is increased by

20% in 2 hours. If the population of bacteria is 2000 after $\frac{k}{\log_e \left(\frac{6}{5}\right)}$ hours, then $\left(\frac{k}{\log_e 2}\right)^2$ is

equal to :

Options :

70819165117. 2

70819165118. 4

70819165119. 8

70819165120. 16

Question Number : 66 Question Id : 70819119989 Question Type : MCQ Option Shuffling : Yes
Is Question Mandatory : No

Correct Marks : 4 Wrong Marks : 1

In the circle given below, let $OA = 1$ unit, $OB = 13$ unit and $PQ \perp OB$. Then, the area of the triangle PQB (in square units) is :

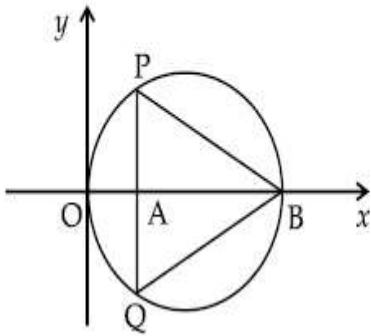

Options :

70819165121. $24\sqrt{2}$

70819165122. $24\sqrt{3}$

70819165123. $26\sqrt{2}$

70819165124. $26\sqrt{3}$

Question Number : 67 Question Id : 70819119990 Question Type : MCQ Option Shuffling : Yes
Is Question Mandatory : No

Correct Marks : 4 Wrong Marks : 1

The value of $\lim_{h \rightarrow 0} 2 \left\{ \frac{\sqrt{3} \sin\left(\frac{\pi}{6} + h\right) - \cos\left(\frac{\pi}{6} + h\right)}{\sqrt{3}h(\sqrt{3}\cos h - \sin h)} \right\}$ is :

Options :

70819165125. $\frac{2}{3}$

70819165126. $\frac{4}{3}$

70819165127. $\frac{2}{\sqrt{3}}$

70819165128. $\frac{3}{4}$

Question Number : 68 Question Id : 70819119991 Question Type : MCQ Option Shuffling : Yes

Is Question Mandatory : No

Correct Marks : 4 Wrong Marks : 1

The maximum slope of the curve $y = \frac{1}{2}x^4 - 5x^3 + 18x^2 - 19x$ occurs at the point :

Options :

70819165129. $(0, 0)$

70819165130. $(2, 2)$

70819165131. $\left(3, \frac{21}{2}\right)$

70819165132. $(2, 9)$

Question Number : 69 Question Id : 70819119992 Question Type : MCQ Option Shuffling : Yes

Is Question Mandatory : No

Correct Marks : 4 Wrong Marks : 1

The value of $\int_{-\pi/2}^{\pi/2} \frac{\cos^2 x}{1 + 3^x} dx$ is :

Options :

70819165133. $\frac{\pi}{2}$

70819165134. 2π

70819165135. $\frac{\pi}{4}$

70819165136. 4π

**Question Number : 70 Question Id : 70819119993 Question Type : MCQ Option Shuffling : Yes
Is Question Mandatory : No**

Correct Marks : 4 Wrong Marks : 1

The number of seven digit integers with sum of the digits equal to 10 and formed by using the digits 1, 2 and 3 only is :

Options :

70819165137. 42

70819165138. 35

70819165139. 77

70819165140. 82

**Question Number : 71 Question Id : 70819119994 Question Type : MCQ Option Shuffling : Yes
Is Question Mandatory : No**

Correct Marks : 4 Wrong Marks : 1

The maximum value of the term independent of 't' in the expansion of $\left(tx^{\frac{1}{5}} + \frac{(1-x)^{\frac{1}{10}}}{t} \right)^{10}$

where $x \in (0, 1)$ is :

Options :

70819165141. $\frac{10!}{\sqrt{3}(5!)^2}$

70819165142. $\frac{2 \cdot 10!}{3\sqrt{3}(5!)^2}$

70819165143. $\frac{2 \cdot 10!}{3(5!)^2}$

70819165144. $\frac{10!}{3(5!)^2}$

Question Number : 72 Question Id : 70819119995 Question Type : MCQ Option Shuffling : Yes

Is Question Mandatory : No

Correct Marks : 4 Wrong Marks : 1

Let $R = \{(P, Q) \mid P \text{ and } Q \text{ are at the same distance from the origin}\}$ be a relation, then the equivalence class of $(1, -1)$ is the set :

Options :

70819165145. $S = \{(x, y) \mid x^2 + y^2 = 4\}$

70819165146. $S = \{(x, y) \mid x^2 + y^2 = 2\}$

70819165147. $S = \{(x, y) \mid x^2 + y^2 = 1\}$

70819165148. $S = \{(x, y) \mid x^2 + y^2 = \sqrt{2}\}$

Question Number : 73 Question Id : 70819119996 Question Type : MCQ Option Shuffling : Yes

Is Question Mandatory : No

Correct Marks : 4 Wrong Marks : 1

Let A be a symmetric matrix of order 2 with integer entries. If the sum of the diagonal elements of A^2 is 1, then the possible number of such matrices is :

Options :

70819165149. 1

70819165150. 4

70819165151. 6

70819165152. 12

**Question Number : 74 Question Id : 70819119997 Question Type : MCQ Option Shuffling : Yes
Is Question Mandatory : No**

Correct Marks : 4 Wrong Marks : 1

Let f be any function defined on \mathbf{R} and let it satisfy the condition :

$$|f(x) - f(y)| \leq |x - y|^2, \forall (x, y) \in \mathbf{R}$$

If $f(0) = 1$, then :

Options :

70819165153. $f(x) > 0, \forall x \in \mathbf{R}$

70819165154. $f(x) < 0, \forall x \in \mathbf{R}$

70819165155. $f(x) = 0, \forall x \in \mathbf{R}$

70819165156. $f(x)$ can take any value in \mathbf{R}

**Question Number : 75 Question Id : 70819119998 Question Type : MCQ Option Shuffling : Yes
Is Question Mandatory : No**

Correct Marks : 4 Wrong Marks : 1

A fair coin is tossed a fixed number of times. If the probability of getting 7 heads is equal to probability of getting 9 heads, then the probability of getting 2 heads is :

Options :

70819165157. $\frac{15}{2^8}$

70819165158. $\frac{15}{2^{12}}$

70819165159. $\frac{15}{2^{13}}$

70819165160. $\frac{15}{2^{14}}$

**Question Number : 76 Question Id : 70819119999 Question Type : MCQ Option Shuffling : Yes
Is Question Mandatory : No**

Correct Marks : 4 Wrong Marks : 1

If $\frac{\sin^{-1} x}{a} = \frac{\cos^{-1} x}{b} = \frac{\tan^{-1} y}{c}$; $0 < x < 1$, then the value of $\cos\left(\frac{\pi c}{a + b}\right)$ is :

Options :

70819165161. $1 - y^2$

70819165162. $\frac{1 - y^2}{y\sqrt{y}}$

70819165163. $\frac{1 - y^2}{1 + y^2}$

70819165164. $\frac{1 - y^2}{2y}$

Question Number : 77 Question Id : 70819120000 Question Type : MCQ Option Shuffling : Yes

Is Question Mandatory : No

Correct Marks : 4 Wrong Marks : 1

In an increasing geometric series, the sum of the second and the sixth term is $\frac{25}{2}$ and the product of the third and fifth term is 25. Then, the sum of 4th, 6th and 8th terms is equal to :

Options :

70819165165. $\frac{26}{3}$

70819165166. $\frac{30}{3}$

70819165167. $\frac{32}{3}$

70819165168. $\frac{35}{3}$

Question Number : 78 Question Id : 70819120001 Question Type : MCQ Option Shuffling : Yes

Is Question Mandatory : No

Correct Marks : 4 Wrong Marks : 1

The sum of the infinite series $1 + \frac{2}{3} + \frac{7}{3^2} + \frac{12}{3^3} + \frac{17}{3^4} + \frac{22}{3^5} + \dots$ is equal to :

Options :

70819165169. $\frac{9}{4}$

70819165170. $\frac{11}{4}$

70819165171. $\frac{13}{4}$

70819165172. $\frac{15}{4}$

**Question Number : 79 Question Id : 70819120002 Question Type : MCQ Option Shuffling : Yes
Is Question Mandatory : No**

Correct Marks : 4 Wrong Marks : 1

Consider the three planes

$$P_1 : 3x + 15y + 21z = 9,$$

$$P_2 : x - 3y - z = 5, \text{ and}$$

$$P_3 : 2x + 10y + 14z = 5$$

Then, which one of the following is true ?

Options :

70819165173. P_1 and P_2 are parallel.

70819165174. P_1 and P_3 are parallel.

70819165175. P_1, P_2 and P_3 all are parallel.

70819165176. P_2 and P_3 are parallel.

**Question Number : 80 Question Id : 70819120003 Question Type : MCQ Option Shuffling : Yes
Is Question Mandatory : No**

Correct Marks : 4 Wrong Marks : 1

The value of $\sum_{n=1}^{100} \int_{n-1}^n e^{x-[x]} dx$, where $[x]$ is the greatest integer $\leq x$, is :

Options :

70819165177. $100(1 - e)$

70819165178. $100(1 + e)$

70819165179. $100e$

70819165180. $100(e - 1)$

Mathematics Section B

Section Id :	708191873
Section Number :	6
Section type :	Online
Mandatory or Optional :	Mandatory
Number of Questions :	10
Number of Questions to be attempted :	5
Section Marks :	20
Mark As Answered Required? :	Yes
Sub-Section Number :	1
Sub-Section Id :	7081911153
Question Shuffling Allowed :	Yes

Question Number : 81 Question Id : 70819120004 Question Type : SA

Correct Marks : 4 Wrong Marks : 0

The difference between degree and order of a differential equation that represents the family

of curves given by $y^2 = a \left(x + \frac{\sqrt{a}}{2} \right)$, $a > 0$ is _____.

Response Type : Numeric

Evaluation Required For SA : Yes

Show Word Count : Yes

Answers Type : Range

Text Areas : PlainText

Possible Answers :

5 to 5.001

Question Number : 82 Question Id : 70819120005 Question Type : SA

Correct Marks : 4 Wrong Marks : 0

The sum of 162th power of the roots of the equation $x^3 - 2x^2 + 2x - 1 = 0$ is _____.

Response Type : Numeric

Evaluation Required For SA : Yes

Show Word Count : Yes

Answers Type : Range

Text Areas : PlainText

Possible Answers :

5 to 5.001

Question Number : 83 Question Id : 70819120006 Question Type : SA

Correct Marks : 4 Wrong Marks : 0

The area bounded by the lines $y = ||x - 1| - 2|$ is _____.

Response Type : Numeric

Evaluation Required For SA : Yes

Show Word Count : Yes

Answers Type : Range

Text Areas : PlainText

Possible Answers :

5 to 5.001

Question Number : 84 Question Id : 70819120007 Question Type : SA

Correct Marks : 4 Wrong Marks : 0

If $y = y(x)$ is the solution of the equation $e^{\sin y} \cos y \frac{dy}{dx} + e^{\sin y} \cos x = \cos x$, $y(0) = 0$; then

$1 + y\left(\frac{\pi}{6}\right) + \frac{\sqrt{3}}{2}y\left(\frac{\pi}{3}\right) + \frac{1}{\sqrt{2}}y\left(\frac{\pi}{4}\right)$ is equal to _____.

Response Type : Numeric

Evaluation Required For SA : Yes

Show Word Count : Yes

Answers Type : Range

Text Areas : PlainText

Possible Answers :

5 to 5.001

Question Number : 85 **Question Id :** 70819120008 **Question Type :** SA

Correct Marks : 4 **Wrong Marks :** 0

The number of solutions of the equation $\log_4(x-1) = \log_2(x-3)$ is _____.

Response Type : Numeric

Evaluation Required For SA : Yes

Show Word Count : Yes

Answers Type : Range

Text Areas : PlainText

Possible Answers :

5 to 5.001

Question Number : 86 **Question Id :** 70819120009 **Question Type :** SA

Correct Marks : 4 **Wrong Marks :** 0

The number of integral values of 'k' for which the equation $3\sin x + 4\cos x = k + 1$ has a solution, $k \in \mathbb{R}$ is _____.

Response Type : Numeric

Evaluation Required For SA : Yes

Show Word Count : Yes

Answers Type : Range

Text Areas : PlainText

Possible Answers :

5 to 5.001

Question Number : 87 **Question Id :** 70819120010 **Question Type :** SA

Correct Marks : 4 Wrong Marks : 0

Let $(\lambda, 2, 1)$ be a point on the plane which passes through the point $(4, -2, 2)$. If the plane is perpendicular to the line joining the points $(-2, -21, 29)$ and $(-1, -16, 23)$, then

$\left(\frac{\lambda}{11}\right)^2 - \frac{4\lambda}{11} - 4$ is equal to _____.

Response Type : Numeric

Evaluation Required For SA : Yes

Show Word Count : Yes

Answers Type : Range

Text Areas : PlainText

Possible Answers :

5 to 5.001

Question Number : 88 Question Id : 70819120011 Question Type : SA

Correct Marks : 4 Wrong Marks : 0

The value of the integral $\int_0^{\pi} |\sin 2x| dx$ is _____.

Response Type : Numeric

Evaluation Required For SA : Yes

Show Word Count : Yes

Answers Type : Range

Text Areas : PlainText

Possible Answers :

5 to 5.001

Question Number : 89 Question Id : 70819120012 Question Type : SA

Correct Marks : 4 Wrong Marks : 0

If $\sqrt{3}(\cos^2 x) = (\sqrt{3} - 1)\cos x + 1$, the number of solutions of the given equation when

$x \in \left[0, \frac{\pi}{2}\right]$ is _____.

Response Type : Numeric

Evaluation Required For SA : Yes

Show Word Count : Yes

Answers Type : Range

Text Areas : PlainText

Possible Answers :

5 to 5.001

Question Number : 90 **Question Id :** 70819120013 **Question Type :** SA

Correct Marks : 4 **Wrong Marks :** 0

Let $m, n \in \mathbb{N}$ and $\gcd(2, n) = 1$. If $30\binom{30}{0} + 29\binom{30}{1} + \dots + 2\binom{30}{28} + 1\binom{30}{29} = n \cdot 2^m$, then

$n + m$ is equal to _____.

(Here $\binom{n}{k} = {}^n C_k$)

Response Type : Numeric

Evaluation Required For SA : Yes

Show Word Count : Yes

Answers Type : Range

Text Areas : PlainText

Possible Answers :

5 to 5.001