

LABORATORY MANUAL

Classes VI-VIII

AT UPPER PRIMARY STAGE

SCIENCE

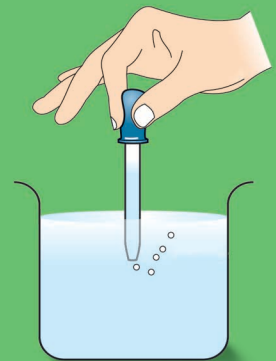



Empowerment of Girl Child, Responsibility of All

Laboratory Manual at Upper Primary Stage Science

Classes VI-VIII

विद्यया ऽ मृतमश्नुते



एन सी ई आर टी
NCERT

**राष्ट्रीय शैक्षिक अनुसंधान और प्रशिक्षण परिषद्
NATIONAL COUNCIL OF EDUCATIONAL RESEARCH AND TRAINING**

ISBN 978-93-5007-300-1

First Edition

December 2014 Pausha 1936

PD 2T MJ

**© National Council of Educational
Research and Training, 2014**

₹ 50.00

*Printed on 80 GSM paper with NCERT
watermark*

Published at the Publication Division
by the Secretary, National Council of
Educational Research and Training,
Sri Aurobindo Marg, New Delhi 110 016
and Chandra Prabhu Offset Printing
Works Pvt. Ltd., C-40, Sector 8, Noida
201301 (U.P.)

ALL RIGHTS RESERVED

- ❑ No part of this publication may be reproduced, stored in a retrieval system or transmitted, in any form or by any means, electronic, mechanical, photocopying, recording or otherwise without the prior permission of the publisher.
- ❑ This book is sold subject to the condition that it shall not, by way of trade, be lent, re-sold, hired out or otherwise disposed of without the publisher's consent, in any form of binding or cover other than that in which it is published.
- ❑ The correct price of this publication is the price printed on this page. Any revised price indicated by a rubber stamp or by a sticker or by any other means is incorrect and should be unacceptable.

**OFFICES OF THE PUBLICATION
DIVISION, NCERT**

NCERT Campus
Sri Aurobindo Marg
New Delhi 110 016 **Phone : 011-26562708**

108, 100 Feet Road
Hosdakere Halli Extension
Banashankari III Stage
Bangalore 560 085 **Phone : 080-26725740**

Navjivan Trust Building
P.O.Navjivan
Ahmedabad 380 014 **Phone : 079-27541446**

CWC Campus
Opp. Dhankal Bus Stop
Panihati
Kolkata 700 114 **Phone : 033-25530454**

CWC Complex
Maligaon
Guwahati 781 021 **Phone : 0361-2674869**

Publication Team

Head, Publication Division : *N.K. Gupta*
Chief Production Officer : *Kalyan Banerjee*
Chief Editor : *Shveta Uppal*
Chief Business Manager : *Gautam Ganguly*
Editorial Assistant : *Mathew John*
Production Assistant : *Mukesh Gaur*

**Cover , Layout Design
and Illustrations**

Digital Expressions

FOREWORD

'The whole world is my laboratory', said a well-known scientist. In fact, we want each child in our schools to believe this, and practise experimenting accordingly. The present manual is a support towards facilitating the children to do so. Through the activities given here, and the questions for reflection, we hope the children will enjoy going through the cognitive processes involved in 'doing' science very naturally. The manual is also expected to help the teachers and parents understand, and engage with, the processes concerned - also with enjoyment!

As you go through this manual, you will realise that it complements the other science teaching-learning materials developed by NCERT for Classes VI-VIII. Please do send your feedback to the team from the Department of Education in Science and Mathematics (DESM) that has so carefully and caringly developed the manual, at desm.nie.ncert@gmail.com.

New Delhi
August, 2014

Director
National Council of Educational
Research and Training

CHILDREN'S BILL OF RIGHTS

A child is every person under the age of 18 years. Parents have the primary responsibility for the upbringing and development of the child. The State shall respect and ensure the rights of the child.

Dignity and Expression

- I have the right to know about my Rights. *(Article 42)*
- I have rights being a child and no matter who I am where I live, what my parents do, what language I speak, what religion I follow, whether I am a boy or a girl, what culture I belong to, whether I am disabled, whether I am rich or poor. I should not be treated unfairly on any basis. Everyone has the responsibility to know this. *(Article 2)*
- I have the Right to express my views freely which should be taken seriously, and everyone has the Responsibility to listen to others. *(Article 12,13)*
- I have the Right to make mistakes, and everyone has the Responsibility to accept we can learn from our mistakes. *(Article 28)*
- I have the Right to be included whatever my abilities, and everyone has the Responsibility to respect others for their differences. *(Article 23)*

Development

- I have the Right to a good education, and everyone has the Responsibility to encourage all children to go to school. *(Article 23, 28, 29)*
- I have the Right to good health care, and everyone has the Responsibility to help others get basic health care and safe water. *(Article 24)*
- I have the Right to be well fed, and everyone has the Responsibility to prevent people from starving. *(Article 24)*
- I have the Right to a clean environment, and everyone has the Responsibility not to pollute it. *(Article 29)*
- I have the Right to play and rest. *(Article 31)*

Care and Protection

- I have the Right to be loved and protected from harm and abuse, and everyone has the Responsibility to love and care for others. *(Article 19)*
- I have the Right to a family and a safe and comfortable home, and everyone has the Responsibility to make sure all children have a family and home. *(Article 9,27)*
- I have the Right to be proud of my heritage and beliefs, and everyone has the Responsibility to respect the culture and belief of others. *(Article 29,30)*
- I have the Right to live without violence (verbal, physical, emotional), and everyone has the Responsibility not to be violent to others. *(Article 28,37)*
- I have the Right to be protected from economic exploitation and sexual exploitation, and everyone has the Responsibility to ensure that no child is forced to work and is given a free and secure environment. *(Article 32,34)*
- I have the Right to protection from any kind of exploitation and everyone has the Responsibility to ensure that I am not being subjected to be taken advantage in any manner. *(Article 36)*

IN ALL ACTION CONCERNING CHILDREN, THE BEST INTERESTS
OF THE CHILD SHALL BE A PRIMARY CONSIDERATION

All these rights and responsibilities are enshrined in the United Nations Convention on the Rights of the Child, 1989. It contains all the rights which children have all over the world. The Government of India signed this document in 1992.

Source: National Commission for Protection of Child Rights (NCPCR), Government of India

PREFACE

The Laboratory Manual in Science for Upper Primary Stage is complementary to the Science Textbooks for Classes VI-VIII. It aims at enhancing children's comprehension of scientific concepts and also acquiring basic experimental skills. In the learning of science, emphasis is on the enquiry approach and hands-on experience instead of lecture method alone. The recommendations of NCF-2005 on Teaching of Science encourage experimental work. This manual covers selected topics in the broad Themes of Food; Materials; The World of the Living; Moving Things, People and Ideas; How Things Work; Natural Phenomena and Natural Resources. At Upper Primary Stage children should be provided plentiful opportunities to engage with the processes of science, observing things closely, recording observations, tabulating data, drawings, making of the set up used, plotting graphs and drawing from what they observe. Sufficient time and opportunities have to be provided for this. The major structural problems at this stage is the lack of experimental facilities. Children of these classes usually have no access to any equipment, even if the school has functional laboratories for higher classes. Many activities described in this manual can be performed with zero-cost equipment.

Based on the science curriculum of Upper Primary Stage, 58 key activities have been given in this manual. All activities conform to a format that includes – What we have to do? What do we need? How do we proceed? What do we observe? What do we conclude? Let us answer. What more can we do? The questions are aimed at testing learner's understanding of concepts underlying the activity. Several activities also include 'Note for the Teacher' that suggests viable alternatives and clarifies certain anticipated difficulties while performing the activities and fill gaps in the knowledge of the teacher. Further, applications are also quoted at several places to relate the concepts to daily life. Some activities have been left open-ended for teachers to innovate, modify and improve. Teachers may adapt or adopt these activities for facilitating their teaching-learning processes.

It is a pleasure to express my thanks and gratitude to all those who have been involved at all stages during the development of this manual. I acknowledge the sincere efforts of Dr Anjni Koul, *Member-Coordinator* of this programme for the development and finalisation of the manual. I am also thankful to all the members of the team who contributed in the

development of this manual. I especially thank Professor Parvin Sinclair, *Director*, NCERT and Professor B.K. Tripathi, *Joint Director*, NCERT for their administrative support and keen interest in the development of this manual.

We warmly welcome comments and suggestions from our readers for further improvement of this manual.

ASHUTOSH K. WAZALWAR
Professor and Head
Department of Education in
Science and Mathematics

LABORATORY MANUAL DEVELOPMENT COMMITTEE

MEMBERS

Alka Mehrotra, *Associate Professor*, DESM, NCERT, New Delhi

B.K. Tripathi, *Joint Director*, NCERT, New Delhi.

Charu Maini, *PGT*, DAV Public School, Sector-14, Gurgaon

Gagan Gupta, *Associate Professor*, DESM, NCERT, New Delhi

K.K. Arora, *Associate Professor*, Zakir Husain Delhi College, Delhi University, Delhi

K.K.Sharma, *Principal (Retd.)*, 1-GH-7, Vaishali Nagar, Ajmer, Rajasthan

Kanhiya Lal, *Principal (Retd.)*, Directorate of Education, Delhi

Lalita C. Kumar, *Associate Professor*, School of Science, Indira Gandhi National Open University, New Delhi

Meenambika Menon, *Manager*, Curriculum and Training, Shiv Nadar Schools, Noida, U.P.

R.R.Koireng, *Assistant Professor*, DESM, NCERT, New Delhi

R.K. Parashar, *Professor*, DESM, NCERT, New Delhi

R.S. Sindhu, *Professor (Retd.)*, DESM, NCERT, New Delhi

Ruchi Verma, *Assistant Professor*, DESM, NCERT, New Delhi

Sarita Kumar, *Associate Professor*, Acharya Narendradev College, Delhi University, Delhi

Shashi Prabha, *Assistant Professor*, DESM, NCERT, New Delhi

Sunita Farkya, *Professor*, DESM, NCERT, New Delhi

Vandana Saxena, *TGT Science (Retd.)*, Kendriya Vidyalaya, Delhi

V.B. Bhatia, *Professor (Retd.)*, Physics Department, Delhi University, Delhi

V.V. Anand, *Professor*, Regional Institute of Education, Mysore

MEMBER-COORDINATOR

Anjni Koul, *Associate Professor*, DESM, NCERT, New Delhi

ACKNOWLEDGEMENTS

The National Council of Educational Research and Training (NCERT) acknowledges the valuable contribution of the individuals and organisations involved in the development of this laboratory manual. The Council acknowledges the valuable contribution of the following academicians for reviewing and refining the manuscript of the laboratory manual: V.B. Bhatia, *Professor (Retired)*, Physics Department, Delhi University, Delhi; Kanhiyalal, *Principal (Retired)*, Directorate of Education, Delhi; Meenambika Menon, *Manager*, Curriculum and Training, Shiv Nadar Schools, Noida, U.P.; K.K. Arora, *Associate Professor*, Zakir Husain Delhi College, Delhi University, Delhi; K.K.Sharma, *Principal (Retired)*, 1-GH-7, Vaishali Nagar, Ajmer, Rajasthan; V.V. Anand, *Professor*, Regional Institute of Education, Mysore; Sarita Kumar, *Associate Professor*, Acharya Narendradev College, Delhi University, Delhi; Sunita Farkya, *Professor*, DESM, NCERT, New Delhi; Gagan Gupta, *Associate Professor*, DESM, NCERT, New Delhi; Alka Mehrotra, *Associate Professor*, DESM, NCERT, New Delhi; R.K. Parashar, *Professor*, DESM, NCERT, New Delhi; Shashi Prabha, *Assistant Professor*, DESM, NCERT, New Delhi; and Anjni Koul, *Associate Professor*, DESM, NCERT, New Delhi.

The Council also acknowledges the efforts of Sadiq Saeed, Puneet Bholra, Dewendra Kumar, *DTP Operators* and Manju Negi, *Computer typist* for typing this laboratory manual. The contributions of the Publication Division in bringing out this laboratory manual are also duly acknowledged.

CONTENTS

FOREWORD	iii
PREFACE	v
ABOUT THIS MANUAL	1
THEME 1 - FOOD	5
1. Germinate seeds to observe how plants grow from seeds	5
2. Test the presence of carbohydrates proteins, fats, in food items	8
3. Observe stomata in leaves	14
4. Study that leaves prepare starch by the process of photosynthesis	16
5. Study how insect pests spoil food grains	19
6. Observation of pond water for presence of micro-organisms	22
THEME 2 - MATERIALS	25
7. Let us explore fabrics that are obtained from fibre	25
8. Classify the given materials on the basis of properties, such as hardness, solubility in water, floats in water and transparency	27
9. A mixture of iron, sand and common salt is provided to you. Separate the three components of this mixture	30
10. Let us explore the nature of the following changes whether they can be reversed or not?	33
(a) Disappearance of common salt on dissolving in water	33
(b) Cutting of potato	33

11.	Reaction between an acid and a base to show the process of neutralisation	35
12.	Identification of the acidic/basic/neutral nature of the salt solutions	38
13.	Differentiate amongst the changes such as folding of paper, tearing of paper and burning of paper	40
14.	Compare the water absorption capacity of fibres obtained from plants, animals and synthetic sources	43
15.	Differentiate between natural and man-made fibres	45
16.	Show that metallic oxides are basic in nature	47
17.	Show that non-metallic oxides are acidic in nature	49
18.	Show that iron is more reactive than copper	51
19.	Show that hydrogen gas is evolved by the action of acids on some metals	53
20.	Show the electric conductivity of metals and non-metals	55
21.	Show that oxygen is necessary for the combustion of a substance	57
22.	Show that fuel/substance should be heated to its ignition temperature to make it burn	59
23.	Measure the temperature of water when it is being heated, when it is boiling and when it is cooling	61
24.	To distinguish between good conductors and poor conductors of heat	66

THEME 3 - THE WORLD OF THE LIVING **69**

25.	Study that leaves release water vapour during the process of transpiration	69
26.	Identify the parts of a flower and distinguish between unisexual and bisexual flowers	72
27.	Let us learn about joints in our body and how they move	75
28.	Find out what the exhaled air contains	79
29.	Understand the mechanism of breathing	82
30.	Observe how water moves between cells in plants	85

31.	Study the different types of reproduction in fungi/ plants	88
32.	Study the mode of reproduction in yeasts	92
33.	Prepare a temporary slide to observe plant cells	95
34.	Create awareness among students about sex-based/ gender-based discrimination that exists in our society	98

THEME 4 - MOVING THINGS, PEOPLE AND IDEAS **105**

35.	Measure the length of your classroom by counting the number of steps and to express the length in cm/m	105
36.	To Find the speed of hopping on one leg	108
37.	To understand the concept of net force	112
38.	To show that liquid pressure depends only upon the height of the liquid column and not the volume of the liquid	115
39.	Explain the working principle of a rubber dropper	118
40.	To show that the increase in weight will increase the static friction between two surfaces	121

THEME 5 - HOW THINGS WORK **124**

41.	Make a bulb glow with the help of a few cells and a few pieces of wire	124
42.	To make a magnet out of the given iron nail and observe its properties	128
43.	To find out whether both the poles of a magnet are equally strong and whether all magnets are equally strong	131
44.	To observe the heating effect of electric current	134
45.	To observe how the strength of an electromagnet depends upon the number of turns of the wire	136
46.	Study electrolysis of water	139

THEME 6 - NATURAL PHENOMENA **141**

- 47. Study how shadows are formed 141
- 48. Show that air exerts pressure 145
- 49. Observe that air expands on heating 147
- 50. To observe the image of a candle flame formed by a concave mirror when the candle is placed at different distances from the mirror 149
- 51. Observe the image of a candle flame formed by a convex lens when the candle is placed at different distances from the lens 152
- 52. To burn a candle in a glass full of water (Fun game) 156
- 53. To verify the laws of reflection 159
- 54. To observe that the appearance of the moon changes every night 162

THEME 7 - NATURAL RESOURCES **165**

- 55. Role of air (if any) in the given activities 165
- 56. Recycle waste paper 168
- 57. Infiltration of water through soil 170
- 58. Cleaning of muddy water 172

PROJECT WORK **174**

EXEMPLAR PROJECTS **175**

EXEMPLAR EDUCATIONAL GAMES **182**

ABOUT THIS MANUAL

Good science education is true to the child, true to life and true to science.

—National Curriculum Framework – 2005

Learning science should have two essential components: an understanding of the body of knowledge and also the processes by which this knowledge is constructed, established and transmitted. But the current status of school science in our country barely satisfies only one of these components and grossly downplays the other. In other words, our system is loaded with product attainment–rote memorisation of facts of science, rather than laying emphasis on the various processes that lead to the generation and accumulation of the concepts of science.

Research has shown that young children are not concrete and simplistic thinkers; they show surprisingly sophisticated and diverse thinking abilities. They also possess a substantial knowledge of the natural world. Therefore, the feeling among certain educationists, that children’s minds are empty vessels awaiting enlightenment by way of instructions from a teacher, is a grossly untenable argument. By the time children reach the upper primary level, they would have come through years of cognitive growth and would have developed the innate ability of different ways of understanding and reasoning about the world around them. In the wake of these realities, science teaching-learning has also undergone far reaching transformation in the past few decades. It has seen a paradigm shift from being teacher-centric to child-centric; from a mere, dull transmission of information to knowledge creation; from passive commentaries in classrooms to vibrant, interactive, activity- based learning; from rote memorisation to creativity, experimentation and experiential learning.

HOW TO MAKE TEACHING-LEARNING OF SCIENCE EXCITING?

Isn’t it exciting to see a piece of magnesium ribbon burning rather than read and memorise how it burns? Isn’t it thrilling to open up a flower and observe its parts rather than read about it in the text? How fun-filled and exciting it would be to hold an ice cube in your palm, (screech and

scream you may) but also observe how solid ice melts into liquid water!! The list of such thrilling experiences that we can plan in a science class is endless.

With an objective of making learning in schools exciting and also building scientific facts based on the child's day-to-day understanding of the world, the *National Curriculum Framework – 2005*, suggested a constructivist paradigm for teaching-learning in our schools. In order to assist the schools/teachers and children, the NCERT has prepared textbooks in science which have an inbuilt, activity-oriented and child-centric approach. It is a known fact that most of our rural schools have no laboratory facilities, and the children are put to great disadvantages because they are deprived of the excitement of performing activities. Keeping these ground realities in focus, we have suggested activities of a very simple nature so that they can be easily performed by the teachers or students with minimal equipment and materials. These activities will help children to learn concepts of science more effectively. It will also stimulate the young minds towards a path of scientific pursuit. Over a period of time, this will help them to build a scientific attitude with all its necessary ingredients like observations, hypothesizing, experimentation, analysis, evaluation and drawing conclusions.

In the present Science Textbooks for Classes VI, VII and VIII, the scientific concepts are framed not along disciplinary lines, but are organised around Themes that are potentially cross-disciplinary in nature. The Themes are – Food; Materials; The World of the Living; Moving Things, People and Ideas; How Things Work, Natural Phenomena and Natural Resources.

Although our textbooks provide numerous opportunities for activities, it was felt that the teachers and students may be provided more details and elaborate explanation for conducting some key activities. In order to satisfy this need, the present Laboratory Manual of Activities has been prepared. An attempt has been made to make this manual a student-friendly. The manual also demonstrates ways in which an activity can be modified or extended further into a simple project that can be undertaken by the child herself. Children must be encouraged to undertake simple, time-bound projects as this will set them on a path of discovery and experimentation even outside the classroom. The subtitles of each activity are such that they reflect a seemingly direct dialogue with the child. For instance, 'What we have to do', instead of the conventional subtitle Aim, addresses the child directly, and instantaneously brings into focus the child's inquisitiveness. Similarly, all other titles have an underlying didactic overtone. Each activity carries a 'Note for the teacher' wherein, teachers are given suitable clues to deal with queries from children and precautions in performing activities.

Suggestions have also been given for alternative material and even alternative activities to help them perform their work more effectively.

BENEFITS OF THE CHILD-CENTRED, ACTIVITY-BASED APPROACH TO LEARNING

- Develops scientific temperament and strengthens curricular concepts;
- Nurtures creativity and innovation;
- Develops logical and analytical thinking;
- Improves observational skills;
- Builds confidence and motivation;
- Provides joyful and meaningful learning experience.

“Science is built up of facts, as a house is with of stones. But a collection of facts is no more a science than a heap of stones is a house”

Henri Poincaré,
La Science et l’Hypothèse (1908)

NOTES _____

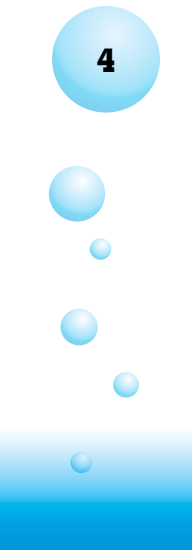

THEME

1

FOOD

ACTIVITY

1



WHAT WE HAVE TO DO?

Germinate seeds to observe how plants grow from seeds.



WHAT DO WE NEED?

Dry whole seeds of gram or moong (green gram), Petri dish, cotton cloth, water.

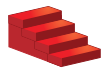

HOW DO WE PROCEED?

1. Soak 20-25 dry whole seeds of gram or moong in a Petri dish or container filled with water.
2. Next day, drain the excess water and cover the seeds with wet cotton cloth.
3. Keep the cotton cloth moist for 2-3 days by soaking them in water at regular intervals. Seeds may be washed or rinsed each day to prevent rotting.
4. Observe the seeds each day.

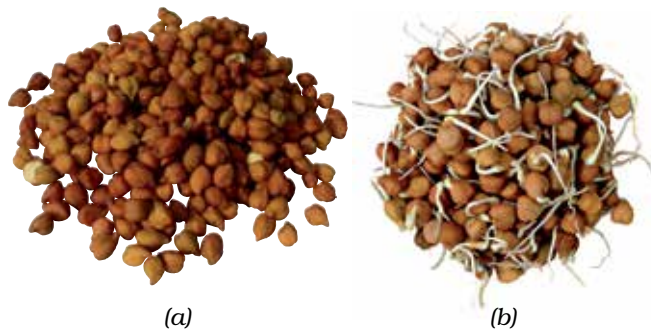

Figure 1.1 Gram (chana) seeds
(a) dry (b) sprouted



WHAT DO WE OBSERVE?

The seeds swell or increase in size on Day 1. Next day, a small white structure emerges from each seed. It gradually elongates during the next 2-3 days and small hair like outgrowths appear around it just behind its tips.



WHAT DO WE CONCLUDE?

- Seeds germinate in the presence of water. Germination is the process of growth of plants from the seeds.
- During germination, the white structure that appears first develops into root.
- The small hair-like outgrowths formed later are root hairs.
- If seeds are kept moist for a few more days, another whitish structure emerges from the same point of the seed, which later develops into a shoot (Fig. 1.2).



a



b

Fig. 1.2

Young plants emerging from seeds



LET US ANSWER

1. Why don't pulses stored in containers in the kitchen at home germinate?
2. Name the part of plant where seeds are located.
3. Do seeds ever germinate on the mother plant? Give reasons for your answer.
4. Do all plants produce seeds? Justify your answer with examples.
5. What are the other methods by which plants can reproduce?



WHAT MORE CAN WE DO?

- Repeat the above activity at home with different seed samples. Observe and report to the teacher after 2-3 days.
- Sow 1-2 germinated seeds in soil or sand in a pot and water them daily. You will observe that seeds develop into a small plant which gradually increases in size. Make observations about the height of the plant each day. Also note down the number of days it takes to produce the first leaf. Draw a figure of the young plant with leaves and roots.

NOTE FOR THE TEACHER

Before the start of the activity, the teacher should explain the concept of seed germination. This activity can be given as a home assignment. The teacher must help the students in observing the process of germination daily.

NOTES _____



ACTIVITY 2**WHAT WE HAVE TO DO?**

Test the presence of carbohydrates, proteins and fats in food items.

2A Test the presence of carbohydrates in food items.**WHAT DO WE NEED?**

Bread slice, potato slice, soaked chickpea seeds, Petri plates, 3% iodine solution, dropper.

**HOW DO WE PROCEED?**

1. Place a bread slice, a potato slice and a few chickpea seeds (with seed coat removed) in separate and clean Petri plates.
2. With the help of a dropper, place 2-3 drops of iodine solution on each item (Fig. 2.1).
3. Note the change in colour and record your observations.



Figure 2.1
Testing for starch

WHAT DO WE OBSERVE?

Blue-black colour appears on bread slice and potato slice, whereas, chickpea seeds do not show any change in colour.

WHAT DO WE CONCLUDE?

- Bread and potato contain starch which gives blue-black in colour on addition of iodine solution. Whereas, chickpea seeds do not contain starch and thus do not show any change in colour.
- Starch is a type of carbohydrate present in many of our food items. Carbohydrates are energy-yielding components of food.



WHAT WE HAVE TO DO?

2B Test the presence of proteins in food items.

WHAT DO WE NEED?

Gram or pea seeds, one banana, test tubes, water, copper sulphate solution, caustic soda, dropper.

HOW DO WE PROCEED?

1. Grind 10-15 seeds of gram or pea into powder form; and mash a piece of banana separately to form a paste.
2. Take a small quantity of these food items in the separate test tubes and label them 'A' and 'B'.
3. Add 10-15 drops of water to each test tube.
4. With the help of droppers, add 2-3 drops of copper sulphate solution and 10 drops of caustic soda to each test tube (Fig. 2.2).
5. Shake well and keep the test tubes aside for a few minutes.
6. Note the change in colour and record your observations.



Figure 2.2
Testing for proteins



WHAT DO WE OBSERVE?

Contents of test tube 'A' containing powdered seeds of gram or pea turn violet in colour whereas test tube 'B' containing mashed banana does not show colour change.



WHAT DO WE CONCLUDE?

- Appearance of violet colour in test tube 'A' confirms that gram or pea seeds contain proteins. As banana does not contain proteins, the test tube 'B' does not show violet colour.
- Protein is another food component present in many of our food items. These are body-building components of the food.



WHAT WE HAVE TO DO?

2C Test the presence of fats in food items.



WHAT DO WE NEED?

Peanuts, dry coconut, rice grains, white paper



HOW DO WE PROCEED?

1. Take three sheets of white paper.
2. Place a few peanuts, pieces of dry coconut (*Khopra*) and rice grains on separate sheets of papers.
3. Fold the paper in such a way that the materials are wrapped in the paper from all the sides.
4. Crush the food items taking care that the paper does not tear.
5. Unfold the papers and remove the food items.
6. Let the papers dry and note the change in texture of paper.
7. Now hold the papers against a source of light and record your observations.



WHAT DO WE OBSERVE?

The papers wrapped around peanuts and dry coconut pieces show oily patches while that containing rice grains does not show such patches. When we hold the paper in front of a light source, the oily patches appear translucent.



WHAT DO WE CONCLUDE?

- Appearance of oily patch on the paper indicates the presence of fats in peanuts and dry coconut. Rice grains do not change the texture of paper as they do not contain fats. Oily patches become translucent because paper has a tendency to absorb oil.
- Fat is another food component present in many of our food items. Like carbohydrates, these are also energy-yielding components of the food.



LET US ANSWER

1. Name the major components of food and at least two food items rich in each food component.
2. What would happen if we eat only carbohydrate-rich food?
3. Match the nutrients in Column 'A' with the food items rich in that nutrient in Column 'B'.

Column 'A'

- a) Protein
- b) Carbohydrate
- c) Fat
- d) Vitamins

Column 'B'

- i) Sesame and mustard seeds
- ii) Leafy vegetables
- iii) Fish and eggs
- iv) Wheat and rice

4. Pick the odd one out and give reasons for choosing that option.
 - a) Nuts, *ghee*, banana, sunflower
 - b) Pea, wheat, egg white, gram
 - c) Mango, potato, sweet potato, sesame
5. Choose the correct option.
 - a) Energy-yielding components of food are

(i) carbohydrates and proteins	(ii) proteins and fats
(iii) carbohydrates and fats	(iv) fats and vitamins

- b) Yolk of egg is rich in
(i) carbohydrates (ii) vitamins (iii) proteins (iv) fats



WHAT MORE CAN WE DO?

Different food items contain different types of nutrients – carbohydrates, proteins, fats, vitamins and minerals.

- Perform the above tests on the food items you eat everyday to find out the type of nutrients contained in them. Analyse whether you are taking a balance diet or not. Visit a nutritionist and consult him/her for a balanced meal for yourself. Modify your meals accordingly to be strong and healthy.
- Take a small piece of banana. Mash it properly and place in a test tube. Add 5-10 drops of Benedict's solution to it. Place the test tube for 2-3 minutes in a water bath containing boiling water. The appearance of reddish-orange colour confirms the presence of carbohydrates in banana.
- Take the white of an egg in a test tube and add few drops of diluted nitric acid to it. Place the test tube in a water bath containing boiling water till a yellow colour appears. Cool the solution and add a few drops of ammonium hydroxide. A bright orange colour confirms the presence of proteins in egg white.
- Find out the various types of food items consumed in different regions of the country. Enlist them and categorise according to the major food components present in them.
- Read about the effects of excess and deficiency of nutrients present in the food. Have a discussion in the class about the effects.

NOTE FOR THE TEACHER

Before performing the activity, the teacher should explain the need and importance of food. The students must be familiar with different components of food and the concept of balanced diet. Teacher should also discuss the importance of each component. Myths about the eating habits may be clarified. A few are as follows:

- Skipping meals is a good way to lose weight.
- All carbohydrate-rich foods are fattening.

Teacher may give the following project to the students. Students may be asked to bring a variety of food items. The students may be divided into three groups. Each group may perform the test for a particular component of food and fill the following table.

Note: Some of the items are listed below. Students can bring these or other food items for performing the test.

Food Item	Carbohydrate	Protein	Fat
Banana			
Boiled rice			
Curd			
Butter			
Milk			
Sweet potato			
Apple slice			
Soyabean			

NOTES _____

ACTIVITY 3**WHAT WE HAVE TO DO?**

Observe stomata in leaves.

**WHAT DO WE NEED?**

Leaves of mango/banyan/bougainvillea/*Salvia*/*Petunia*/balsam, micro-slide, forceps, water, cover glass, needle, Compound microscope.

**HOW DO WE PROCEED?**

1. Take a mature leaf from any of the plants listed above.
2. Tear the lower epidermis and you will notice a thin, peel on the edges of the torn portions of the leaf.
3. Carefully remove a small peel with the help of forceps and place it on a micro-slide in a few drops of water.
4. Place a cover glass on it without allowing any air bubbles beneath.
5. Observe the peel under the low power of the microscope and note the different types of cells (Fig. 3.1).
6. Locate the pores in the cells and with the help of your teacher, observe it under high power.
7. Draw the figure of a pore along with its surrounding structure.
8. Repeat the same procedure for the upper epidermis.

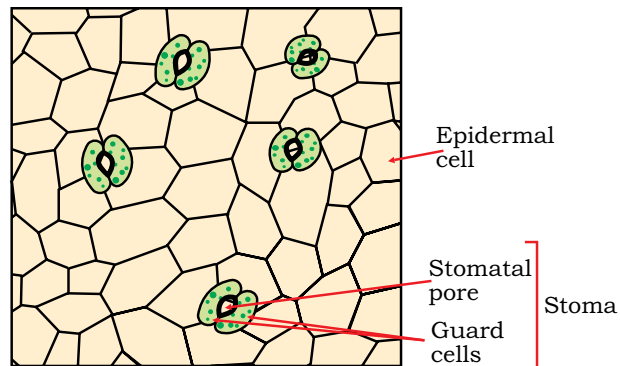

Figure 3.1
Lower epidermal peel of a leaf

**WHAT DO WE OBSERVE?**

- We observe a number of compactly arranged cells.
- In between the cells we see a number of tiny pores.

- Each pore is surrounded by two specialised bean-shaped cells.
- There are several pores scattered in the peel with no specific arrangement.



WHAT DO WE CONCLUDE?

- The leaf peels comprise of a number of cells which are more or less identical in shape and size. They are epidermal cells.
- Tiny pores along with their bean-shaped cells (guard cells) are called stomata (Singular-stoma).



LET US ANSWER

1. Which surface of the leaf has more number of stomata?
2. Name the bean-shaped cells of stoma.
3. What are the functions of stomata?
4. Are stomata present in submerged water plants?
5. What is the function of the pore in stomata?



WHAT MORE CAN WE DO?

Leaf samples of different plants can be brought to the class and students may be asked to peel their upper and lower surfaces and mount them. They may be asked to count the number of stomata in the microscopic field and compare the number with two or three other plants.

NOTE FOR THE TEACHER

- Teacher should demonstrate the process of removal of peel and its mounting. Students can perform the activity using other leaf materials. Focusing the peel under low power and later under high power lens must be done under the supervision of the teacher.
- Teacher should discuss the importance of stomata – for gaseous exchange during respiration and photosynthesis; and transpiration.

ACTIVITY 4**WHAT WE HAVE TO DO?**

Study that leaves prepare starch by the process of photosynthesis.

**WHAT DO WE NEED?**

A leaf of any plant, spirit, a beaker, test tube, burner, tripod stand, water, Petri plate, iodine solution, dropper, forceps.

**HOW DO WE PROCEED?**

1. Insert a leaf into a test tube gently with the help of forceps.
2. Pour spirit into the test tube so that the leaf completely dips in it.
3. Keep the test tube in a beaker half-filled with water.
4. Place the beaker on a tripod stand as shown in the figure 4.1.
5. Boil the water till the spirit becomes green in colour and the leaf becomes colourless.
6. Take out the leaf carefully from the test tube and wash it with water.
7. Place it in a Petri plate and add a few drops of iodine solution.



Figure 4.1
Set-up for extraction of chlorophyll



WHAT DO WE OBSERVE?

As we add iodine solution on the colourless leaf, it turns blue-black.



WHAT DO WE CONCLUDE?

- When we boil the leaves in spirit they become colourless because chlorophyll pigments leach out.
- Leaves contain starch which gives blue-black colour with iodine solution.
- Starch is synthesised in the green leaves in the presence of sunlight by the process of photosynthesis.
- Starch gets stored in leaves or gets transported to other parts of the plant.



LET US ANSWER

1. Why do leaves become colourless after boiling in spirit?
2. Why is the test tube containing leaf with spirit boiled in a water bath?
3. What would happen if:
 - a) a fresh green leaf of a plant receiving enough sun light is treated with iodine solution?
 - b) a fresh green leaf of a plant placed in dark for 2-3 days is treated with iodine solution?
 - c) variegated leaves (leaves with some green portions and some non-green portions) are treated with iodine solution?
3. Why is photosynthesis essential for survival of all organisms on earth?
4. Keep a potted plant having leaves of different colours in dark for 2-3 days and perform the iodine test. Now, keep the same plant in sunlight for 3-4 hours and repeat the iodine test. Record your observations and give reasons.



WHAT MORE CAN WE DO?

- Separate non-green and green parts of the variegated leaves. Follow the procedure as discussed in the above activity. Note down the difference in colour of spirit.

- Place a potted plant with green leaves in a dark room for 1-2 days. Pluck a leaf and perform the iodine test. You will observe that leaves do not turn blue-black in colour. This is because of utilisation of starch stored in the leaves and lack of photosynthesis in the absence of sunlight.
- Select a healthy green leaf of a potted plant. Cover a portion of the leaf completely with the black paper and leave it undisturbed for 1-2 days. Now pluck the leaf, remove the black paper and perform the iodine test. You will observe that the uncovered portion of the leaf turns blue-black colour because of the presence of the starch, while, the covered portion of leaf does not become blue-black. Can you give reasons for the results obtained?

NOTE FOR THE TEACHER

- Before the activity, the teacher may discuss the concept of photosynthesis in the class. Since the activity involves use of spirit and heating, it may be demonstrated by the teacher or can be done by the students under the supervision of teacher.
- After the activity, the teacher may relate the presence of starch in the leaves with the presence of starch in various food items. This will clarify the concept of transportation of food from the leaves to other parts of the plants.

NOTES _____

ACTIVITY 5**WHAT WE HAVE TO DO?**

Study how insect pests spoil food grains.

**WHAT DO WE NEED?**

A few infected/infested/spoiled grains/seeds of wheat/rice/pulses, three plastic containers with lids, hand lens, micro-slides, brush and forceps.

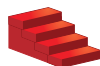
**HOW DO WE PROCEED?**

1. Collect three different kinds of spoiled grains (contaminated) of seeds—any pulse, rice and wheat.
2. Keep a fistful of each type of seeds in a container and mark the containers, A, B and C.
3. Carefully observe the following in the seeds
 - Are there small holes in some seeds?
 - Is there a powdery material at the bottom of the container?
 - Are there net-like threads around the grains?
 - Do the seeds emit a foul/sour smell?
4. Now observe if there are any kind of organisms—worms/insects—in the container? In case they are present, observe if there is only one kind of organism or do you find different types of worms/insects in the container? Note the colour, shapes and structure of the insects/worms (Fig. 5.1 & Fig 5.2)
 Try to break hollow grain and observe the presence of any organism inside the grain.
5. Draw sketches of the observed creatures in your notebook.
6. Observe if all the seeds are infected/spoiled or only a few.
7. With the help of forceps or a brush pick up these organisms and place in a drop of water on a slide.
8. Observe them by using a hand lens.
9. Leave the grains in the containers and observe them again after a few days.



Figure 5.1
Grains infected with insect pests



Figure 5.2
Grains infected with microorganisms



WHAT DO WE OBSERVE?

- The number of infected/spoiled grains varies in different samples.
- There are a number of worm-like creatures which may be seen crawling within the spaces or inside the grains (if you break open the seeds).
- The infected grains will have holes and may have become hollow leaving only the seed coat.
- Some of the grains may have been reduced to a powdery material.
- The rice grains may also show webbing between them.
- After a few days, many more grains would have got converted into powdery material. There may be a whitish covering over grains and also a sour and musty odour.



WHAT DO WE CONCLUDE?

- The stored grains are attacked by different insect pests. Different life stages of insects, such as larvae (seen as worm-like creatures) and adults (reddish-brown organisms) make holes in the grains and damage them.
- The infected grains become hollow and a powdery material is seen at the bottom of the container.
- The seeds may be infected by micro-organisms resulting in the musty odour.
- The infected grains are unfit for human consumption. They will cause illness, nausea and vomiting. These seeds are dead and hence they cannot germinate.



LET US ANSWER

1. What are the different ways in which seeds can get spoilt?
2. What will happen to the seeds if we do not store them properly?
3. Name a few storage structures used in your house. Find out if they are safe for storage?
4. Have you observed how grains are stored in huge godowns?
5. Sometimes when we soak chick pea seeds in water, a few of them float, whereas other seeds sink to the bottom. Give reasons.



WHAT MORE CAN WE DO?

- Take a few healthy and a few contaminated gram seeds. Wash them and soak them in water in separate containers for a day. Now try to sprout the seeds as you did in the seed germination experiment. Share your observations with your classmates.
- Study the preserved specimens of insect pests which infect seeds. Learn their features with the help of your teacher. Try to understand the different stages in their life cycle. Find out which stage of their life cycle infects the seeds.
- Find out the methods of storage in rural areas. Collect information about the different methods of storage and prepare a report.

NOTE FOR THE TEACHER

- This can be a group activity of 4-5 students.
- The task of collecting infected seeds may be assigned to students a few days in advance.
- Teacher may help students in identifying infected/spoiled seeds and collecting pests from them.
- Students may also read about the different insect pests that damage our crop plants leading to extensive losses.
- Students may be encouraged to suggest suitable storage methods for preventing contamination.

NOTES _____



ACTIVITY 6**WHAT WE HAVE TO DO?**

Observation of pond water for presence of micro-organisms.

**WHAT DO WE NEED?**

A glass tumbler, pond/stagnant water samples, muslin cloth, dropper, micro-slide, cover glass, Petri plate, Compound microscope.

**HOW DO WE PROCEED?**

1. Collect water in a glass tumbler from a clean pond or stagnant pool.
2. If water is turbid, filter it through muslin cloth.
3. With the help of a dropper, place a drop of filtered water on a clean micro-slide.
4. Place a cover glass on the drop of water without letting in any air bubbles.
5. Observe under the Compound microscope.

**WHAT DO WE OBSERVE?**

Though water appears clean to the naked eye, different kinds of minute organisms can be observed under the microscope. Figures of some common micro-organisms are given below. Identify the organisms observed in the slide by comparing with these figures (Fig. 6.1 & 6.2).

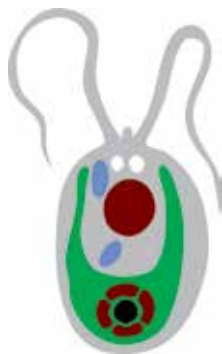

Chlamydomonas



Spirogyra



Amoeba

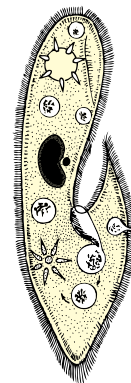

Paramecium

Figure 6.1 Algae

Figure 6.2 Protozoa



WHAT DO WE CONCLUDE?

Water contains several kinds of small organisms which are not visible to the naked eye but can be seen with the help of a Compound microscope. These organisms are called micro-organisms. Water, however, may also contain several organisms which are visible to the naked eye. They cannot be called micro-organisms.



LET US ANSWER

1. Why are micro-organisms so called?
2. Is pond water fit for drinking? Give reason for your answer.
3. How do our ponds get polluted?
4. Name the four major groups of micro-organisms. Give two examples for each group.
5. Match the organisms given in Column 'A' with the group to which they belong given in Column 'B'.

Column 'A'

- a) *Spirogyra*
- b) *Staphylococcus*
- c) *Paramecium*
- d) *Rhizopus*

Column 'B'

- i) Fungi
- ii) Protozoa
- iii) Algae
- iv) Bacteria

6. Pick the odd one out and give reasons.
 - a) *Amoeba, Euglena, Paramecium, Chlamydomonas*
 - b) *Penicillium, Aspergillus, Spirogyra, Yeast*
 - c) *Lactobacillus, Rhizopus, Staphylococcus, Rhizobium*
7. State whether the following statements are *true* or *false*. If false, correct the statement.
 - a) Fungi are autotrophs while protozoa can be autotrophs or heterotrophs.
 - b) *Rhizopus* lives in the root nodules of leguminous plants and helps in nitrogen fixation.
 - c) Water may contain certain bacteria which cause harmful diseases.



WHAT MORE CAN WE DO?

Micro-organisms thrive in almost every kind of environment– soil, water, air, hot springs, etc. Different habitats have different kinds of micro-organisms. To understand the concept, the following activities can be performed.

- Collect some moist soil from the field in a beaker. Half-fill the beaker with water. Keep the beaker aside till the soil particles settle down. Take a drop of water on a micro-slide and observe under the microscope. You will observe some organisms which will be different from those observed in pond water.
- Place a drop of curd on a glass slide and observe under the Compound microscope. Curd contains a few bacteria, such as *Lactobacillus* and *Staphylococcus*.

NOTE FOR THE TEACHER

- Teacher should introduce the concept of micro-organisms before performing the activity. Four major groups of micro-organisms should be explained along with their characteristic features.
- Students should be asked to collect samples of water from different places. They should be asked to draw the outline structure of organisms observed under the microscope. Organisms observed in different water samples may be compared and identified by the teacher. This would clarify the concept of the diversity of micro-organisms present in water.
- Teacher should also discuss the threats and benefits of micro-organisms. Students should not be averse to eating curd after observing the bacteria present in it. The benefits of bacteria in curds must be discussed.
- Teacher may give the following project to students. Students may be divided into four groups. Each group may select a particular micro-organism/group of micro-organisms, gather information about the microorganism and fill the following table.

S.No.	Name of the micro-organism	Where it lives	Harmful or useful	Figure

THEME

2

MATERIALS

ACTIVITY

7



WHAT WE HAVE TO DO?

Let us explore fabrics that are obtained from fibre.



WHAT DO WE NEED?

A cotton duster (the one we use in kitchen) or mop cloth (used for floor moping), a needle, a pair of scissors.

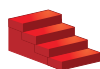

HOW DO WE PROCEED?

1. Spread the given piece of cloth on your table.
2. Cut the sides with the help of scissors to loosen the network of threads (Fig. 7.1).
3. Pull out the threads (yarn) from the cloth using a needle. (Fig. 7.2)
4. Keep the thread on the table and hold it at one end with your hand and scratch it with your nail and observe what happens. (Fig. 7.3 and Fig. 7.4)



Figure 7.1
Cutting a piece
of cloth



Figure 7.2
Pulling a thread
from cloth



Figure 7.3
Splitting the yarn into
thin strands



Figure 7.4
Yarn splits up into
thin strands



WHAT DO WE OBSERVE?

It is observed that a thread (yarn) from the cloth splits into many strands/fibres on scratching with nail.



WHAT DO WE CONCLUDE?

- Cloth is made of _____.
- Yarn is made of several _____.
- Strand of yarn is made of _____.



LET US ANSWER

1. What is the difference between yarn and strand?
2. What difference do you find between strand and fibre?
3. What is the ultimate constituent of cloth?



WHAT MORE CAN WE DO?

- Take some other types of clothes and try to find out whether the yarn is made of single strand or many strands.



NOTE FOR THE TEACHER

- Make sure that students note that thread (yarn) of the cloth is not made of several strands in each case.

NOTES _____

ACTIVITY 8



WHAT WE HAVE TO DO?

Classify the given materials on the basis of properties, such as hardness, solubility in water, floats in water, and transparency.



WHAT DO WE NEED?

Wax, glass piece (with blunt edges), oil coated paper, sugar, green leaf, piece of coal, piece of wood, a coin, a piece of sponge, a container, water, spoon/glass rod, a sheet of white paper.

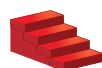

HOW DO WE PROCEED?

1. Take the given materials one by one and observe the materials which are compressed on applying some pressure. Record your observations in a Table 8.1.
2. Take a container (like beaker, glass bowl, etc.) and fill it half with water. Add any given material and see whether it floats or sinks (Fig. 8.1). Now stir it with a spoon or glass rod and check if it is soluble or insoluble. Repeat the same steps with other materials also. Record your observations in the Table 8.1.
3. Take a strip of white paper and make a dark spot on it (Fig. 8.2). Place the given materials one by one on the spot and observe its visibility whether you can see it clearly (Fig. 8.3), not clearly (Fig. 8.4) or not able to see it at all (Fig. 8.5). Record your observations in the Table 8.1.



Figure 8.1
Some objects float in water while others sink in it

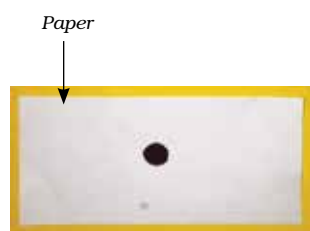

Figure 8.2
Paper with a dark spot

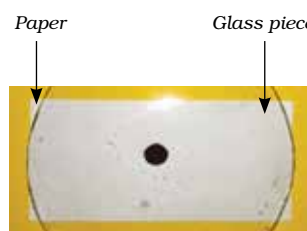

Figure 8.3
Transparent material kept on dark spot



Figure 8.4
Translucent material kept on dark spot



Figure 8.5
Opaque material kept on dark spot



WHAT DO WE OBSERVE?

Record all the observations in a Table 8.1.

Table 8.1

Material	Properties			
	Hard/Soft	Soluble/Insoluble in water	Sinks/Floats in water	Transparency (transparent/translucent/opaque)
Wax				
Glass piece				
Oil coated paper				
Sugar crystals				
Green leaf				
Coal				
Wood				
Coin				
Piece of sponge				



WHAT DO WE CONCLUDE?

- Materials which were easy to press are soft, such as wax, green leaf, sponge, etc. Materials which were difficult to press are hard, such as glass piece, sugar crystals, coin, coal and wood.
- Materials which dissolved in water are called soluble materials, such as sugar. Materials which did not dissolve in water after stirring for a long are called insoluble materials, such as wax, glass piece, coin, coal, wood, green leaf, sponge etc.
- Some materials float in water such as wax, wood and coal. Some materials sink in water, such as sugar, coin, glass piece.
- Materials through which you can see clearly are transparent, such as glass piece. Materials through which you cannot see clearly are translucent, such as oil coated paper. Materials through which you cannot see at all are opaque, such as coal, wood, sugar, wax, coin, and sponge.

We conclude that materials are classified on the basis of their properties.



LET US ANSWER

1. Mention any two properties of sugar that you have identified from this activity?
2. You are advised to drive your bicycle slowly on a foggy day. Why?
3. Find the odd one out from the following-
Coal, wood, glass piece, sugar, candle.
Justify your answer.



WHAT MORE CAN WE DO?

- A project can be done on this concept.
- Collect samples (at least 10) of different materials from your surroundings and classify them on the basis of their properties.

NOTE FOR THE TEACHER

- Give freedom to students to explore and observe.
- Kindly see that the materials used in the activity should not harm the user.
- Students may take materials of their choice, but see that these materials show all the properties.

NOTES

ACTIVITY 9**WHAT WE HAVE TO DO?**

A mixture of iron, sand and common salt is provided to you. Separate the three components of this mixture.

**WHAT DO WE NEED?**

A mixture of iron filings, sand and common salt, magnet, filter paper, funnel, two beakers, Petri plate, spoon/glass rod, heating device, tripod stand, wire gauze, a sheet of paper, match box.

**HOW DO WE PROCEED?**

Step I. Take a little amount of the given mixture of iron filings, sand and common salt and keep it separately. Spread rest of the mixture on a sheet of paper or in a Petri plate (Fig. 9.1). Move a magnet over the surface of the mixture (Fig. 9.2). What happens? Do you find that iron filings are removed from the mixture with the help of a magnet?



Figure 9.1
Mixture of iron filings,
sand and common salt



Figure 9.2
Iron filings get attracted
towards magnet

Step II. Take the remaining mixture from which iron filling have been removed in a beaker. Add sufficient amount of water to cover the mixture. Stir the contents of the beaker with a spoon/glass rod for some time.

Filter the content with the help of a funnel and filter paper (Fig. 9.3). Record your observations.

Step III. Heat the filtrate obtained in step II using a heating device (Fig. 9.4). Heat the content till most of the water evaporates.



Figure 9.3
Filtration using a
filter paper



Fig. 9.4
Heating a beaker
containing salt water



WHAT DO WE OBSERVE?

Step I. Iron filings stick to the magnet and are thus separated.

Step II. Sand remained undissolved in water and is separated by filtration.

Step III. On heating the filtrate, water is evaporated and a white coloured substance (common salt) is left at the bottom of the beaker.

Compare the separated components with the mixture you left aside.



WHAT DO WE CONCLUDE?

- Magnetic substances like iron are separated by a magnet.
- Substances which are insoluble in water (such as sand) can be separated by filtration.
- Substances which are soluble in water (such as common salt) can be separated by evaporation.



LET US ANSWER

1. Is there any method other than filtration by which we can separate sand from water? Explain.
2. Why does the filter paper permit the passage of the salt solution, whereas it retains the sand?
3. The filtrate containing salt when heated becomes dry. Where has the water gone and why?
4. Suggest a method to collect and use the water which disappears on boiling?



WHAT MORE CAN WE DO?

- List the methods which are used at your home to separate components of mixtures.
- Find out the ways used to purify water which is supplied at your home from water station.

NOTE FOR THE TEACHER

- You can make various types of mixtures and give opportunities to students to use different methods of separation based on their different properties.
- Let the students discuss their findings in the class.

NOTES _____

ACTIVITY 10**WHAT WE HAVE TO DO?**

Let us explore the nature of the following changes whether they can be reversed or not?

- Disappearance of common salt on dissolving in water.
- Cutting of potato

**WHAT DO WE NEED?**

Common salt, water, glass tumbler, heating device, china dish, wire gauze, tripod stand, potato, knife, match box.

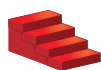
**HOW DO WE PROCEED?**

- Take a tea spoon of common salt in a glass tumbler and dissolve it in minimum amount of water. (Fig. 10.1)
 - Where has the salt gone?
Can we get the disappeared salt back?
 - Transfer the content of glass tumbler in a china dish and heat it till water evaporates completely (Fig. 10.2).



Figure 10.1
Dissolving
salt in water



Figure 10.2
Heating a china dish
containing salt water

What do you observe?

- Take a potato (Fig. 10.3). Cut it into small pieces with the help of a knife (Fig. 10.4a) (be careful while using a knife).
 - Can you get the potato back in its original form from these pieces (Fig. 10.4b)?



Figure 10.3
A potato



(a)



(b)

Figure 10.4: A potato cut into pieces



WHAT DO WE OBSERVE?

- Common salt dissolved in water and thus disappeared. It was recovered back by the evaporation of water.
- On cutting the potato it was converted into pieces. However, there was no way to get back the material (potato) to its original shape and size.



WHAT DO WE CONCLUDE?

- Dissolution of common salt in water is a change, which can be reversed because salt can be obtained back on evaporation of water.
- Cutting a potato into pieces is a change which cannot be reversed.



LET US ANSWER

1. Making of roti from dough and baking of a roti are two changes. Are these changes similar or different? Justify your answer.
2. Raw mango ripens with time. Is this a reversible/non-reversible change?
3. Classify the following changes into reversible/non-reversible.

(a) Wetting of cement	(b) Drying of a wet cloth
(c) Squeezing of lemon	(d) Opening of a window



WHAT MORE CAN WE DO?

Look at your surroundings. List at least ten changes which can be reversed and ten changes which cannot be reversed.

NOTE FOR THE TEACHER

While dealing with the chapter on “Changes Around Us”, it is suggested to take students outside the classroom and let the children explore, observe, record and discuss the changes taking place.

ACTIVITY 11**WHAT WE HAVE TO DO?**

Reaction between an acid and a base to show the process of neutralisation.

**WHAT DO WE NEED?**

Dilute hydrochloric acid, dilute sodium hydroxide solution, phenolphthalein indicator, test tubes, dropper, test-tube stand.

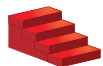
**HOW DO WE PROCEED?**

1. Take about 5 mL of dilute hydrochloric acid in a test tube. (Be careful while handling the acid solution)
2. Add 1-2 drops of phenolphthalein indicator to the solution and note down if any change in colour.
3. Take about 10 mL of dilute sodium hydroxide solution in another test tube.
4. Take out sodium hydroxide solution with the help of a dropper and start adding this solution drop wise into the test tube containing hydrochloric acid till a change in colour is observed (Fig.11.1).
5. What colour do you get?
6. With the help of another dropper, take out hydrochloric acid and start adding it drop wise into the coloured solution obtained above. Note your observations.

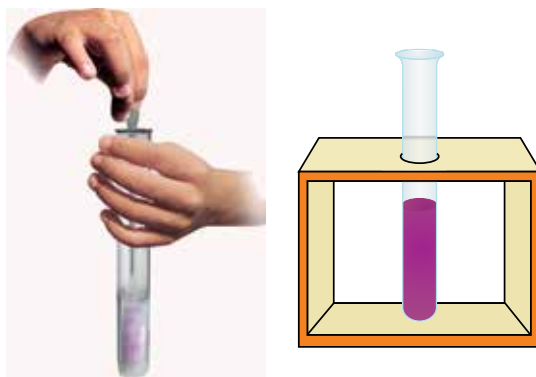

Figure 11.1 Process of neutralisation



WHAT DO WE OBSERVE?

- Colour of the hydrochloric acid solution does not change on addition of phenolphthalein indicator.
- On adding nearly 5 mL sodium hydroxide solution to the mixture of hydrochloric acid and phenolphthalein solution, the colour of the mixture changes to pink.
- On addition of hydrochloric acid solution to the pink solution, the colour starts fading gradually and finally the solution becomes colourless.



WHAT DO WE CONCLUDE?

- Phenolphthalein indicator remains colourless in the acidic solution while its colour changes to pink in basic solution.
- It is found that on adding a base in an acid, a stage reaches when effect of acid is neutralised by base and vice-versa as indicated by colour change of indicator.



LET US ANSWER

1. What is the colour of phenolphthalein solution?
2. Can you name any natural indicator?
3. What products are formed when hydrochloric acid neutralises sodium hydroxide solution?
4. Suggest a way to obtain solid salt from the neutral solution obtained in this activity.
5. Why are you advised to take antacid solution/tablet when you suffer from acidity?



WHAT MORE CAN WE DO?

- Look for some home remedies used for treating (i) indigestion and (ii) ant bite
- Make indicator solutions from *Jamun*, Red cabbage, Periwinkle (*Sadabahar*), Rose and check their colour in solutions of some acidic and basic substances.

NOTE FOR THE TEACHER

- While concluding, the teacher must emphasise the process of neutralisation in which an acid reacts with a base to form salt and water.

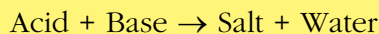

In such reactions heat is also produced.

- To prepare 1 litre dilute hydrochloric acid, take nearly 5 mL of concentrated hydrochloric acid and 995 mL of water. Add acid to water slowly. The dilute hydrochloric solution is ready to use.
- To prepare 1 litre dilute sodium hydroxide solution, dissolve 2g sodium hydroxide pellets in 1 litre water.
- To prepare 1% solution of phenolphthalein, dissolve 1g of the solid phenolphthalein in 100 mL of ethyl alcohol.

NOTES _____

ACTIVITY 12**WHAT WE HAVE TO DO?**

Identification of the acidic/basic/neutral nature of the salt solutions.

**WHAT DO WE NEED?**

Ferric chloride, sodium acetate, sodium chloride, water, litmus paper (red and blue), dropper, test tubes, test tube stand, watch glass.

**HOW DO WE PROCEED?**

1. Take about 1 mL of ferric chloride solution in a watch glass. Take a piece of blue litmus paper and dip it in this solution.
Do you observe any change in the colour of blue litmus paper? Similarly, dip a piece of red litmus paper in the solution and observe the change.
2. Repeat the above steps with sodium acetate solution and sodium chloride solution, respectively. Note the observations.

**WHAT DO WE OBSERVE?**

- Ferric chloride solution turns blue litmus paper red but it does not change the colour of red litmus paper (Fig. 12.1).
- Sodium acetate solution turns red litmus paper blue but does not change the colour of blue litmus paper (Fig. 12.2).
- Sodium chloride solution does not change the colour of either red or blue litmus paper (Fig 12.3).



Figure 12.1
Testing of litmus papers in
ferric chloride solution



Figure 12.2
Testing of litmus papers in
sodium acetate solution



Figure 12.3
Testing of litmus papers in
sodium chloride solution



WHAT DO WE CONCLUDE?

- Ferric chloride solution is acidic.
- Sodium acetate solution is basic.
- Sodium chloride solution is neutral.



LET US ANSWER

1. Name any two natural products which are acidic in nature.
2. Do you know any indicator other than litmus used to differentiate an acidic substance from a basic substance?
3. What colour does an acidic, a basic and a neutral salt give when a drop of their solution is placed on a red litmus paper. Give reason for your answer.
4. Name two flowers which we can use to prepare indicator solutions.



WHAT MORE CAN WE DO?

A number of indicators can be prepared from substances such as red cabbage, beet root, rose, bougainvillea, etc.

NOTE FOR THE TEACHER

- Prepare a solution of sodium acetate by dissolving a pinch of solid sodium acetate in 5 mL of distilled water in a test tube.
- Similarly, prepare solutions of ferric chloride and sodium chloride salts.
- Label all the test tubes with the names of the salts (Fig. 12.4).
- The salts can be tested for their acidic, basic and neutral nature with other natural indicators also.
- Always prepare fresh salt solutions in water. In place of ferric chloride, you can take copper sulphate also.

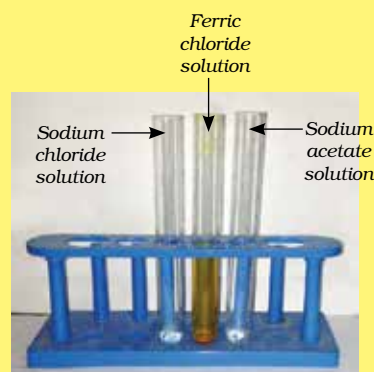

Figure 12.4

ACTIVITY 13**WHAT WE HAVE TO DO?**

Differentiate amongst the changes such as folding of paper, tearing of paper and burning of paper.

**WHAT DO WE NEED?**

Used papers, candle/spirit lamp, match box, steel plate/Petri plate, a pair of tongs.

**HOW DO WE PROCEED?**

Step I. Take a used paper and fold it (Fig. 13.1). How many times you were able to fold the paper? Unfold the paper.

Do you get the paper in its original shape and size?

Step II. Take the same paper and tear it into as many pieces as you wish (Fig. 13.2). Now try to get the paper in its original shape and size. Are you successful in doing this?

Do you think that in the above two steps any new substance is formed?

Step III. Take a few pieces of the paper and burn them. Collect the product formed in a steel plate or Petri plate (Fig. 13.3). (Be careful while burning the paper).

Compare the product formed with the original pieces of paper.

What do you observe?

Do you think a new substance has been formed in this change?



Figure 13.1
Folding a paper



Figure 13.2
Pieces of a paper



Figure 13.3
Burning of a paper



WHAT DO WE OBSERVE?

Step I. On folding the paper, one can fold it 6 to 7 times.

On unfolding the paper, it regained its original shape and size.

Step II. The pieces of paper can be joined with the help of glue. However, one cannot get the paper in its original form.

The changes observed in Steps (I) and (II) do not give any new substance/product.

Step III. On burning the pieces of paper, they turned black, whereas original paper pieces were white in colour. Smoke was also observed during burning of the paper pieces. This shows new substances (solid and gaseous) were formed in this change.



WHAT DO WE CONCLUDE?

- In Step I and Step II only change in physical state/property was noticed and no new substance is formed. Hence, these are physical changes.
- However, in Step III new substances are formed. Hence, it is a chemical change.



LET US ANSWER

1. Are the changes observed in the above three steps reversible/non-reversible?
2. Is burning of crackers-
 - (a) Physical change which can be reversed
 - (b) Physical change which cannot be reversed
 - (c) Chemical change which can be reversed
 - (d) Chemical change which cannot be reversed.
3. Comment on the following changes –
 - (a) Boiling of an egg
 - (b) Beating of an egg
 - (c) Knitting of a sweater
 - (d) Greying of hair.



WHAT MORE CAN WE DO?

Make a list of different changes taking place in your surroundings. Categorise them as physical and chemical changes giving appropriate reasons.

NOTE FOR THE TEACHER

- Teacher can arrange a field trip for the students to observe various types of changes. Let the students categorise these into physical and chemical changes. At the same time these changes can be categorised as reversible or non-reversible.
- Teacher should focus on the importance of conserving resources, such as saving of paper, etc.
- The concept of desirable changes (such as baking of food materials) and undesirable changes (such as rotting of food) may be highlighted and discussed in the class. The undesirable changes should be discouraged, as these may be responsible for the wastage of valuable materials and may be harmful. For example, rotting of food stuff at homes and food grains in the godowns may be a great loss to the country.

NOTES _____

ACTIVITY 14**WHAT WE HAVE TO DO?**

Compare the water absorption capacity of fibres obtained from plants, animals and synthetic sources.

**WHAT DO WE NEED?**

2 × 2 cm pieces of cotton, wool and nylon fabrics, beakers/glass tumblers, funnel, tripod stand, water, weighing balance.

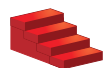
**HOW DO WE PROCEED?**

1. Take the cotton fabric (2 × 2 cm) and weigh it.
2. Immerse the fabric in water filled in a beaker (Fig. 14.1).
3. Pour out the excess water by tilting the beaker (Fig. 14.2).
4. Place a funnel on a tripod stand and keep a beaker or glass tumbler under the stem of the funnel.
5. Take out the wet fabric from the beaker and put it in the funnel (Fig. 14.3).
6. Wait till water stops dripping out from the fabric.
7. Now weigh the wet fabric and note your observation in the Table 14.1.
8. Repeat the same steps for the woolen and nylon fabrics.



Figure 14.1
Fabric immersed in water in a beaker



Fig 14.2
Pouring out the excess water by tilting the beaker



Figure 14.3
Wet fabric placed in a funnel



WHAT DO WE OBSERVE?

Table 14.1

S.No.	Material	Mass of dry fabric (A g)	Mass of wet fabric (B g)	Mass of water absorbed by fabric (B-A) g	Mass of water absorbed by 1g of fabric $\left(\frac{B-A}{A}\right)g$
1	Cotton (Plant fabric)				
2	Wool (Animal fabric)				
3	Nylon (Synthetic fabric)				



WHAT DO WE CONCLUDE?

Water absorption capacity of fibres is in the order: Cotton > Wool > Synthetic

LET US ANSWER

1. In the above activity we could see that fabric can hold water. Do they hold air likewise?
2. Why do different fibres differ in water holding capacity?
3. Why cotton clothes are preferred to synthetic clothes in summer season?
4. Why do wet cotton clothes take longer time for drying than nylon clothes?



WHAT MORE CAN WE DO?

Students may collect different sample of fabric from a tailor shop/home and look for their water absorption capacity.

NOTE FOR THE TEACHER

- Teacher may initiate a discussion among children regarding the application of fabrics used in different seasons.

ACTIVITY 15**WHAT WE HAVE TO DO?**

Differentiate between natural and man-made fibres.

**WHAT DO WE NEED?**

Threads of cotton, wool, polyester and nylon, spirit lamp, forecep, match box.

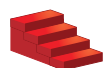
**HOW DO WE PROCEED?**

1. Take the woollen thread and hold it with a forecep (Fig. 15.1).
2. Burn it in the flame of a heating device (Fig. 15.2).

What do you observe?

3. Repeat the above steps for other threads and note your observations.



Figure 15.1
Holding a
woollen thread
with a forecep



Figure 15.2
Burning of a
woollen thread

**WHAT DO WE OBSERVE?**

Natural fibres (cotton, wool) burn without melting while man-made fibres (polyester, nylon), first become soft and then melt to form a lump before burning.

**WHAT DO WE CONCLUDE?**

The fibres which are converted into ash on burning are natural fibres and those which melt and form a bead before burning are man-made (synthetic) fibres.

**LET US ANSWER**

1. Why are we advised not to wear synthetic clothes while working near a flame?
2. Why are parachutes made of synthetic fibres?



WHAT MORE CAN WE DO?

You may check for the bio-degradability of natural and synthetic fibres by performing the following project.

- Place two earthen pots in the school garden.
- Mix various samples of cotton, silk, jute, etc. fabrics which you can collect from a tailor shop or home with moist soil and put in one earthen pot and label it as “A”.
- Label the second pot as ‘B’ and put various samples of synthetic fibres such as nylon, polyester, etc. in it after mixing with moist soil.
- Leave these two pots undisturbed for at least a month and take care that soil remains moist throughout the span of the experiment. After that take out the fabrics and note their conditions.

Prepare a project report on your observations.

You should compare the two types of fabrics before and after completing the project and discuss the findings in your class.

NOTE FOR THE TEACHER

- Children should collect the pieces of natural and synthetic fibres well in advance.
- You can show children various materials made of synthetic fibres and natural fibres.
- Teacher may initiate discussion on pollution due to synthetic materials.

NOTES _____

ACTIVITY 16**WHAT WE HAVE TO DO?**

Show that metallic oxides are basic in nature.

**WHAT DO WE NEED?**

Magnesium ribbon, distilled water, red and blue litmus papers, sand paper, spirit lamp, watch glass, a pair of tongs, match box.

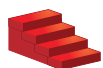
**HOW DO WE PROCEED?**

1. Take about 5 cm of magnesium ribbon. Clean it properly with a sand paper if it is not shiny.
2. Hold magnesium ribbon with the help of a pair of tongs.
3. Bring the free end of magnesium ribbon near the flame of the spirit lamp and let it burn (Fig. 16.1). (Do not stare at the burning magnesium).
4. Collect the powdery ash (formed on burning of magnesium ribbon) in a watch glass.
5. Add small amount of distilled water to the ash and stir it.
6. Dip one by one blue and red litmus papers in the solution and observe the change in colour of litmus papers (Fig. 16.2).



Figure 16.1
Burning of
magnesium ribbon



Figure 16.2
Testing of
solution of ash
with litmus
papers

**WHAT DO WE OBSERVE?**

- There is no change in colour of blue litmus paper.
- The red litmus paper turns blue.



WHAT DO WE CONCLUDE?

The magnesium oxide after dissolving in water shows basic character.

On burning, magnesium forms magnesium oxide (ash), when this is dissolved in water it forms magnesium hydroxide (basic in nature).



LET US ANSWER

1. Why should we clean the magnesium ribbon before burning?
2. What is the name of the product obtained on burning of magnesium ribbon?
3. Name the product obtained on dissolution of ash (formed in this activity) in water.
4. Why there is no change in colour of the blue litmus paper when it is dipped into the oxide solution ?
5. Why does the solution of magnesium oxide turn red litmus paper blue?



WHAT MORE CAN WE DO?

Test the solution of ash with other indicators like turmeric powder, extracts of some flowers.

NOTE FOR THE TEACHER

- It is dangerous to look continuously for long at the burning magnesium ribbon. The teacher should advice children not to stare at the burning ribbon.
- If the magnesium ribbon is not shining, it may take a long time to ignite, so it is better to clean the ribbon with a sand paper.
- Basic nature of iron oxide can also be tested by taking rust.
- Avoid using candle to burn magnesium ribbon.

ACTIVITY 17**WHAT WE HAVE TO DO?**

Show that non-metallic oxides are acidic in nature.

**WHAT DO WE NEED?**

Powdered sulphur, water, glass tumbler/gas jar, lid, watch glass, red and blue litmus papers, deflagrating spoon, spirit lamp, match box.

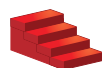
**HOW DO WE PROCEED?**

1. Take some sulphur powder in a deflagrating spoon (Fig. 17.1) and heat it over a spirit lamp.
2. Introduce the spoon with burning sulphur into a glass tumbler/jar containing some water (Fig. 17.1). Take care that spoon should not dip in the water.
3. Cover the tumbler/jar with a lid to stop the escape of gas produced during burning of sulphur.
4. Remove the spoon after some time.
5. Shake the covered tumbler well to dissolve the gas in water.
6. Transfer the solution in watch glass (Fig. 17.2a).
7. Dip one by one red and blue litmus papers in the solution (Fig. 17.2b) and observe the change in the colour of the litmus papers.



Figure 17.1
Burning of sulphur powder

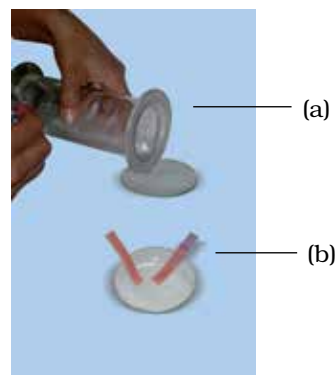

Figure 17.2
Testing of solution with litmus papers

**WHAT DO WE OBSERVE?**

- There is no change in the colour of red litmus paper.
- Blue litmus paper turns red.



WHAT DO WE CONCLUDE?

The non-metallic oxide after dissolving in water shows acidic character. Sulphur on burning in air forms sulphur dioxide gas, which dissolves in water and form sulphurous acid.

Sulphur + Oxygen (from air) → Sulphur dioxide

Sulphur dioxide + Water → Sulphurous acid

Sulphurous acid turns the colour of blue litmus paper red.



LET US ANSWER

1. Write the name of the gas formed on burning of sulphur?
2. Write the name of the acid which is formed on dissolving the gas produced on burning of sulphur in water.



WHAT MORE CAN WE DO?

Perform the activity with carbon and with other non-metals if available. Use other indicators also to show their acidic character.

NOTE FOR THE TEACHER

- Do not take too much sulphur to burn. It pollutes air. Effect of environmental pollution should be discussed in the class.
- You can make an improvised spoon. Take a metallic cap of any bottle and wrap the cap with metallic wire and bend it as shown in the figure 17.3.



Figure 17.3
Improvised
spoon

ACTIVITY 18**WHAT WE HAVE TO DO?**

Show that iron is more reactive than copper.

**WHAT DO WE NEED?**

100 mL beaker, shaving blades or iron nails, copper sulphate, distilled water, blue and red litmus papers, dilute sulphuric acid, dropper.

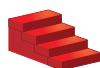
**HOW DO WE PROCEED?**

1. Take 100 mL beaker and add about 50 mL of water in it.
2. Pour about a tea spoonful of copper sulphate in water and shake well to dissolve it.
3. Add a few drops of dilute sulphuric acid to the solution by using dropper.
4. Drop a shaving blade into the solution. Handle the shaving blade carefully.
5. After nearly half an hour observe the change in the colour of blade as well as of copper sulphate solution (Fig. 18.1).



Figure 18.1
Change in colour of the copper sulphate solution due to reaction with iron (shaving blade)

**WHAT DO WE OBSERVE?**

The blue colour solution of copper sulphate first fades and then changes to green and a brown deposit is formed on the shaving blade.

**WHAT DO WE CONCLUDE?**

Copper metal which is brown in colour is deposited on shaving blade due to its displacement from copper sulphate by iron. Green colour of the solution is due to the formation of iron sulphate.

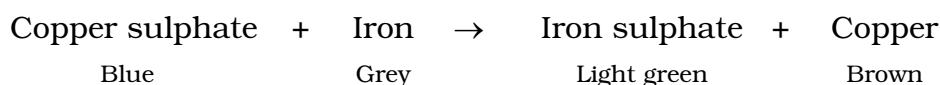



LET US ANSWER

1. Why does the colour of the shaving blade placed inside copper sulphate solution becomes brown after sometime?
2. Why does the blue colour of copper sulphate solution ultimately changes to green?



WHAT MORE CAN WE DO?

- The activity can be repeated using iron nails in place of shaving blade.
- Take the solutions of other metal salts and add different metals and note down if displacement reaction takes place.

NOTE FOR THE TEACHER

We should prepare nearly 5% solution of copper sulphate. Too much concentrated solution will mask the green colour of iron sulphate formed and with very dilute solution reaction will be very slow.

NOTES _____

ACTIVITY 19**WHAT WE HAVE TO DO?**

Show that hydrogen gas is evolved by the action of acids on some metals.

**WHAT DO WE NEED?**

Aluminium foil, dilute hydrochloric acid, conical flask, rubber cork, glass tube, match box, candle.

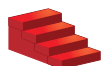
**HOW DO WE PROCEED?**

1. Take few small pieces of aluminum foil in a dry conical flask.
2. Pour 2-3 mL of dilute hydrochloric acid in the above conical flask and set up the apparatus as shown in Fig. 19.1.
3. Observe, what is happening.
4. Take a burning match stick or burning candle near the mouth of the glass tube (Fig 19.2).



Figure 19.1
Formation of
hydrogen gas



Figure 19.2
Testing
hydrogen gas
by burning

**WHAT DO WE OBSERVE?**

- On adding acid into a conical flask containing aluminium foil, bubbles of some gas evolve.
- On bringing ignited candle near the mouth of the glass tube, the gas burns with “Pop” sound.



WHAT DO WE CONCLUDE?

- Hydrogen gas is evolved in the reaction between aluminium and dilute hydrochloric acid.

Aluminium + Dilute Hydrochloric acid → Aluminium chloride + Hydrogen gas.

- Hydrogen gas burns forming water, producing a sound, generally called pop sound.

Hydrogen gas + Oxygen gas (from air) → Water (pop sound is produced)



LET US ANSWER

- What substance is produced when hydrogen gas burns with “Pop” sound?
- Name the component of air which reacts with the gas produced by the reaction of aluminium and dilute hydrochloric acid forming water when ignited candle is brought near the mouth of test tube.
- Will the component of air react with the gas if burning match stick does not come in contact with the gas?
- Give at least two uses of aluminium.



WHAT MORE CAN WE DO?

- The reaction of aluminium with strong base like sodium hydroxide can also be shown for the liberation of hydrogen gas.
- Repeat the activity by taking a non-metal (say coal, sulphur, etc.)

NOTE FOR THE TEACHER

- Teacher should discuss and show the reaction of other metals with different acids in class.
- On the basis of the activity the teacher may initiate discussion on differentiation between metals and non-metals.

ACTIVITY 20**WHAT WE HAVE TO DO?**

Show the electric conductivity of metals and non-metals.

**WHAT DO WE NEED?**

Electric cell, bulb, copper wire, iron nail, zinc granules, sulphur lump, coal piece.

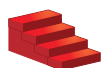
**HOW DO WE PROCEED?**

1. Make an electric circuit by connecting an electric cell, a bulb with copper wires as shown in Fig. 20.1.
2. Bring one by one free ends of the wires of the circuit in contact with the two ends of the different samples of metals (such as iron nail, zinc granules) and non-metals (such as coal piece, sulphur lump) and observe, the cases in which the bulb glows (Fig. 20.2).



Figure 20.1
Electric tester



Figure 20.2
Testing whether the bulb glows when the tester is in contact with a iron nail

**WHAT DO WE OBSERVE?**

- Bulb in the circuit glows in case of iron nail and zinc granule.
- Bulb does not glow in case of sulphur lump and coal piece.

**WHAT DO WE CONCLUDE?**

Iron nail and zinc granule being metals are good conductors of electricity, while sulphur lump and piece of coal which are non-metals do not conduct electricity.



LET US ANSWER

1. Will the bulb glow if we use painted piece of iron? Justify your answer.
2. Why do we use plastic coated wires while making electrical connections?
3. Why are we advised to wear shoes having rubber soles while working with electric appliances?



WHAT MORE CAN WE DO?

We should perform this activity using alloys of metals such as brass, stainless steel and other materials like a piece of paper, a piece of cloth, a drinking straw, etc.

NOTE FOR THE TEACHER

The students should be informed that graphite is made up of carbon which is a non-metal but is a good conductor of electricity while other forms of carbon such as diamond, coal and charcoal are non-conductors of electricity.

NOTES _____

ACTIVITY 21**WHAT WE HAVE TO DO?**

Show that oxygen is necessary for the combustion of a substance.

**WHAT DO WE NEED?**

Two candles, match box, glass jar or a beaker.

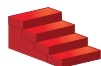
**HOW DO WE PROCEED?**

1. Light the two candles and fix them on a table (Fig. 21.1).
2. Let both the candles burn for some time.
3. Now cover one of the candles with a glass jar or beaker and observe it for some time (Fig. 21.2).



Figure 21.1
Burning candles



Figure 21.2
Burning candle covered
with a breaker

**WHAT DO WE OBSERVE?**

- It is found that the candle which is not covered continues burning.
- The candle which is covered, continues burning for some time and gets extinguished (Fig. 21.3).



Figure 21.3
Covered candle
extinguishes



WHAT DO WE CONCLUDE?

This activity shows that oxygen is necessary for combustion process.

Candle continues burning for some time until the whole oxygen (present in the air) available in the jar or beaker is consumed. After that it stops burning due to non-availability of oxygen.



LET US ANSWER

1. Is combustion a physical change or a chemical change?
2. Name a gas which helps in extinguishing fire?
3. If you cover a burning kerosene lamp with a jar, will it also stop giving light after some time? Justify your answer.
4. Why do we cover a person with blanket when his/her clothes catch fire?



WHAT MORE CAN WE DO?

Carbon dioxide extinguishes fire. Perform an activity to show it.

Prepare carbon dioxide gas by adding half tea-spoon of baking soda (sodium hydrogen-carbonate) in a test tube filled one-third with vinegar. Now bring an ignited match stick to the mouth of the test tube. The flame will be extinguished at once.

NOTE FOR THE TEACHER

- While discussing the role of oxygen in combustion, discuss the role of carbon dioxide in extinguishing fire also.
- Show the students a fire extinguisher and discuss its working.

ACTIVITY 22**WHAT WE HAVE TO DO?**

Show that fuel/substance should be heated to its ignition temperature to make it burn.

**WHAT DO WE NEED?**

Paper, candle, water, match box.

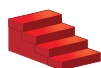
**HOW DO WE PROCEED?**

1. Make two paper cones.
2. Heat one empty paper cone on the flame of candle and observe (Fig 22.1a).
3. Fill the other paper cone one-third with water and heat it on the flame and observe (Fig 22.1b).

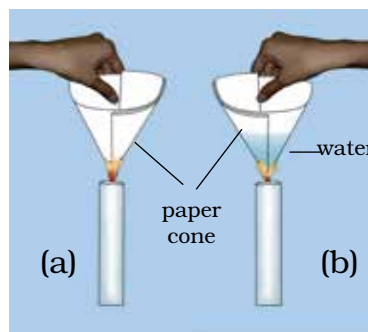

Figure 22.1
Heating (a) empty paper cone
(b) water in a paper cone

**WHAT DO WE OBSERVE?**

The empty paper cone starts burning immediately but the paper cone filled water does not burn and water in it becomes hot.

**WHAT DO WE CONCLUDE?**

- A substance burns when the temperature reaches to its ignition temperature.
- The empty paper cone starts burning immediately because its ignition temperature is reached fast.
- The paper cone filled with water does not burn because the heat is transferred to water and the ignition temperature is not reached.



LET US ANSWER

1. Why do we observe forest fires generally after autumn?
2. Why is it difficult to burn a heap of green leaves, but dry leaves catch fire easily?
3. Why do we pour water on the fire caused by non-electrical appliance?



WHAT MORE CAN WE DO?

- Try to burn paper, wood and card board. Note the time taken by the substances to catch fire. Which of these substances has lowest ignition temperature?

NOTE FOR THE TEACHER

- The teachers can take students to fire station to make them aware of different methods of extinguishing fire and different types of fire extinguishers.
- Persons from fire station may be called to school to give lecture and train the children to learn preventive measures from fire disaster.
- For making paper cones, ask the students to use waste papers. This helps in saving the papers and focuses on the concept of reuse.
- When children are heating paper cones, the teacher should caution them to be careful.

NOTES

ACTIVITY 23**WHAT WE HAVE TO DO?**

Measure the temperature of water when it is being heated, when it is boiling and when it is cooling.

**WHAT DO WE NEED?**

A laboratory thermometer, a container to heat water, a source of heat and a stop watch.

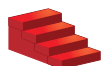
**HOW DO WE PROCEED?**

1. Fill the container about half with water.
2. Put it on a stove or some other source of heat.
3. Measure the temperature of water every two minutes. Remember that we always use Celsius scale of temperature.

CAUTION. You must use **laboratory thermometer** for measuring temperature of water and not **Clinical thermometer**. A clinical thermometer is used to measure our body temperature. It is marked from 35°C and 42°C. It could break if used for measuring temperatures much higher than 42°C.

The thermometer should be immersed in the liquid. It should be vertical and should not touch sides and the bottom of the container (Fig 23.1).

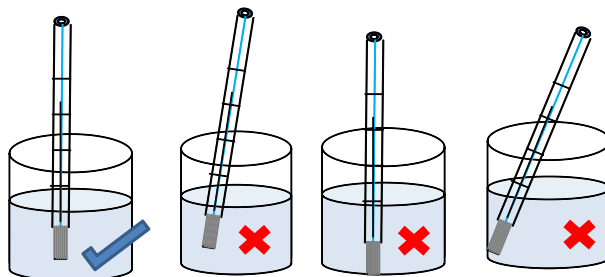

Figure 23.1. The correct way of placing the thermometer in a liquid.

- The thermometer should be held vertical.
- You must read while the bulb of the thermometer is immersed in the liquid.
- You must read the mark at the end of the shining mercury thread.
- Your eye should be right in front of the mark to be read (Fig. 23.2).

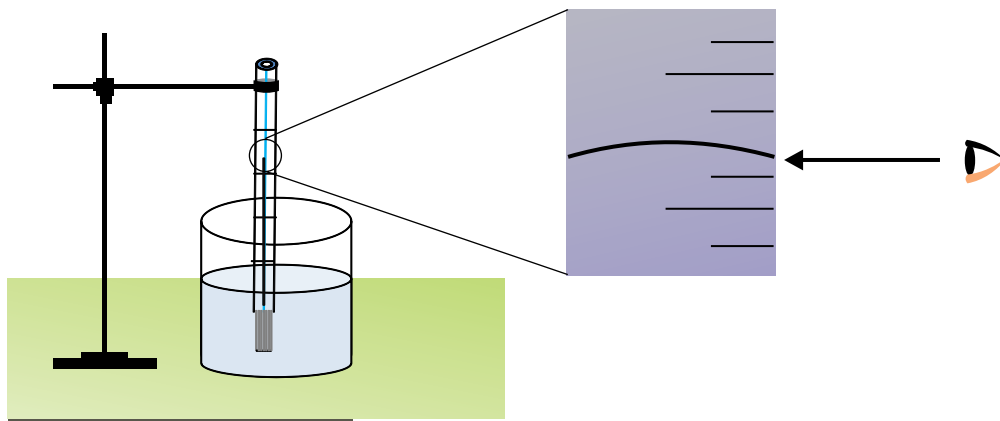

Figure 23.2 Correct method of reading thermometer

- Record your observations in the Table 23.1. You can add as many rows as you need.

Table 23.1 Temperature of water

S.No	Time (min)	Temperature (°C)
1.	0	30 (Room Temperature)
2.	2	
3.	4	

- Let the water boil. Keep measuring the temperature of boiling water. Insert your observations in the Table 23.1.
- Having taken a few observation while the water is boiling, remove the container from the source of heat.
- Measure the temperature of the cooling water a few times. Insert your observations in the Table 23.1.
- Draw a graph of your observation. It will look something like that shown in Fig. 23.3.

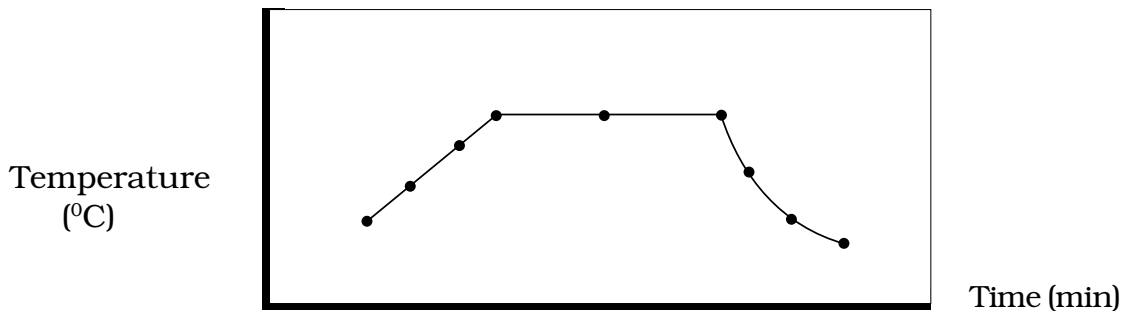

Figure 23.3



WHAT DO WE OBSERVE?

- We have noted down the temperature of water while it is being heated, while it is boiling and while it is cooling.
- We found that at first the temperature of water increases, the temperature remains constant when water is boiling and then it comes down when heating is stopped.
- We have also drawn a graph of our observations.



WHAT DO WE CONCLUDE?

We find that as long as the water is boiling, there is no change in its temperature. The temperature of boiling water remained constant.

At my place the temperature of boiling water is °C.



LET US ANSWER

1. Why should the bulb of the thermometer be immersed in the liquid while we read the temperature? You should see what happens when you take the thermometer out of the liquid and try to read the temperature.
2. Why should your eye be exactly in front of the mercury thread to be read? What happens if the position of your eye is on one side of the mark or the other?
3. Is the cooling part of your graph similar to the heating part of the graph?
4. Is the temperature of boiling water at your place different from 100 °C? If yes, why is it so? Discuss with your teacher.
5. Can this thermometer be used to measure our body temperature? If not, give reasons.



WHAT MORE CAN WE DO?

- Melt a little ice in a cup. Find the temperature of ice when it is melting. Record your observations in a Table as in the above Activity. In the light of your observations, discuss if the temperature of melting ice can be taken as another fixed point of the temperature scale.
- Find the temperature of tea when you are ready to drink it.
- Find the temperature of hot water which you use for your bath on a winter day.

Temperature of your favourite cold drink (*lassi*/sherbet/coffee/fresh lemon/...).

NOTE FOR THE TEACHER

It will be better if the teacher forms groups of two students each. In a group, one student holds the thermometer correctly (see Fig. 23.1) while her partner notes down the temperature at regular intervals. After the observations of one member are complete, she holds the thermometer correctly and her partner notes down the temperature. However, both of them make their own observations and draw their own graphs.

Discussion on the Activity can be held collectively when the whole class has finished its work.

When children are heating the water, the teacher should caution them to be careful. She should herself be alert so that any mishap is prevented.

To lead the discussion in the class, the teacher may find the following points helpful:

- A mobile phone can also be used as a stop watch.
- As far as possible the observations should be taken at regular intervals. This makes Table appear more organised and drawing the graph easier.
- Help students in placing the thermometer correctly in the liquid. If some students find it difficult to read the temperature correctly, draw their attention to Fig. 23.2.
- Help children in drawing graphs. The subject may have to be revisited.

- Remember that when water is boiling, the temperature does not change because the heat supplied goes into changing water into steam.
- Water does not cool linearly. At first the cooling is fast and then it becomes slow.
- Explain that water does not always boil at 100°C because the special conditions are not satisfied. For the same reason, the boiling point of water varies from place to place. Discourage students from cramming that water boils at 100°C . It is sufficient for them to know the temperature at which water boils **at their place**.
- Draw the attention of the students to the fact that the laboratory thermometer usually has marking from -10°C to 110°C . In contrast, the clinical thermometer has markings only between 35°C and 42°C . If students are not able to understand why it is so, explain that the body temperature is in this range most of the time.
- Explain that we have adopted the Celsius scale in this country. Therefore, the students should use this scale to express temperatures.

NOTES _____

ACTIVITY 24**WHAT WE HAVE TO DO?**

To distinguish between good conductors and poor conductors of heat.

**WHAT DO WE NEED?**

We need three objects, material of one should be metal and of the other two could be plastic, rubber or wood. The objects should roughly be of the same length, thickness, width, etc. The possibilities for the objects are spoons, narrow strips, rods or tubes.

**HOW DO WE PROCEED?**

1. Fill half of a large glass tumbler, a large plastic mug, or a large beaker with hot (not boiling) water.

Be Careful if you are heating water in the glass.

2. Place the three objects in water in such a way that one end of each is out of water (Fig. 24.1).
3. After two minutes touch the ends of the objects which are out of water (exposed ends) one by one.
Repeat this observation after two more minutes.
4. Record your observations in Table 24.1

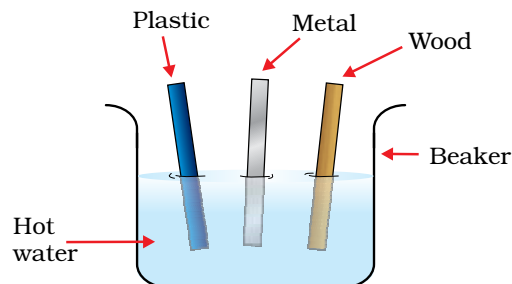

Figure 24.1

Table 24.1

Material	Had become hot/had not become hot	
	After 2 min	After 4 min



WHAT DO WE OBSERVE?

- The exposed end of the object made of metal became hot almost immediately.
- The exposed end of the object made of glass became warm after almost minutes.
- The exposed end of the object made of wood/rubber did not become hot even after four minutes.



WHAT DO WE CONCLUDE?

We conclude that the exposed ends of objects made of metal become hot while the exposed ends of objects made of plastic/wood/rubber do not become hot. Object made of glass may become warm after some time. That means in some materials like metals, heat can travel easily from one end to the other while in others like plastic it does not travel so easily. Materials in which heat can travel easily are called **good conductors of heat**, or simply **conductors of heat**. Materials in which heat cannot travel easily are called **poor conductors of heat**, or **insulators of heat**.



LET US ANSWER

1. Why are handles of cooking metal utensils made of plastic or wood?
2. In her kitchen, Ishita has utensils of the same size made of copper, aluminium and stainless steel. Which of these utensils should she use for heating water so that minimum amount of fuel is used?
3. Why did we want that all objects be roughly of the same length, thickness and width in this activity ?
4. Is the temperature of the hotter ends of objects higher or lower than the temperature of your body?
5. If we do not wish to touch the exposed ends of objects, which instrument can tell us if the end is hot or not?
6. In your experience, are good conductors of heat also good conductors of electricity? (Hint: Think of the plastic handle of a screw driver).



WHAT MORE CAN WE DO?

Perform the activity with carbon and with other non-metals if available.

NOTE FOR THE TEACHER

- If the water is being heated in the glass, the teacher must be alert so that no untoward incident takes place.
- The teacher should make sure that the water is not too hot to cause any harm to students.
- Waiting for two minutes before touching the objects is to ensure that there is sufficient time for the heat to travel to the exposed end. Repeating observation after a few more minutes is to allow long enough time for the heat to travel to the exposed end.
- By requiring all the objects to be roughly of the same size, we have tried to remove all other variables to be able to study the relationship between only time and conductivity of the material. A general principle of science is that the effect of only one variable on another should be studied at a time.
- The teacher should remind students that heat flows from a higher temperature to a lower temperature. The object that appears hotter to us is at a higher temperature than our body and heat flows from it to our body.
- The teacher may use the occasion to discuss why iron objects feel colder than wooden objects on a cold winter day, and hotter on a hot summer day.
- Conductivity of copper is $1\frac{1}{2}$ times that of aluminium and about 20 times that of stainless steel.

NOTES _____

THEME

3

THE WORLD OF THE LIVING

ACTIVITY

25



WHAT WE HAVE TO DO?

Study that leaves release water vapour during the process of transpiration.



WHAT DO WE NEED?

A healthy well-watered potted plant, dry polythene bags, thread/rubber bands.

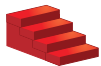

HOW DO WE PROCEED?

1. Take a healthy, well-watered leafy plant, growing under the sun.
2. Select two branches each with 10-12 leaves.
3. Remove all the leaves from one branch and retain the leaves of the other branch.
4. Cover both branches with polythene bags and tie their mouths with thread/rubber bands (Fig. 25.1).
5. Tie up the mouth of an empty polythene bag and keep it under sunlight along side the plant.
6. Observe the inner surface of each polythene bag after a few hours.



WHAT DO WE OBSERVE

We observe that the inner surface of polythene bag enclosing the leafy branch of plant has more number of water droplets. The leafless branch has negligible number of water droplets as compared to the leafy branch.

The inner surface of the empty polythene bag does not have any water droplets.

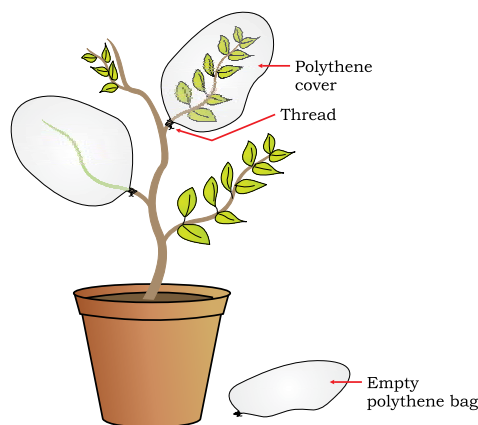

Figure 25.1
Branches covered with polythene bags



WHAT DO WE CONCLUDE?

We conclude that plants release water vapours from their leaves which condense on the inner surface of polythene bags in the form of water droplets. Water vapours move out of the leaves through minute openings called stomata. This process is called transpiration.



LET US ANSWER

1. Why do leaves release water vapour by the process of transpiration?
2. Name the pores in leaves through which plants transpire?
3. Why do desert plants lose less water as compared to leafy plants?
4. Why do water vapours released by the leaves appear as water droplets on the inner surface of the polythene bags?
5. Which of the plants will have more rate of transpiration — a plant growing under sun or a plant growing under shade? Give reasons for your answer.



WHAT MORE CAN WE DO?

Select two leafy branches in a potted plant. Apply a layer of oil on the leaves of one of the branches. Tie polythene bags as in the above activity, on the selected branches. You will observe that the inner surface of the bag enclosing the oil-layered leaves do not have any water droplets. This is because of the reason that stomatal openings are clogged by the oil.

NOTE FOR THE TEACHER

Before the activity, teacher may discuss the concept of transpiration in the class. The plants selected for the activity should be those which are growing under the sun. The indoor plants and those growing under shade should not be selected. The teacher can discuss the role of stomata in transpiration. Other roles of stomata should also be discussed.

NOTES _____

ACTIVITY 26**WHAT WE HAVE TO DO?**

Identify the parts of a flower and distinguish between unisexual and bisexual flowers.

**WHAT DO WE NEED?**

Flowers of *Petunia*/*Cassia*/*Datura*/*Hibiscus*/lady's finger and flowers of pumpkin/bitter gourd/snake gourd/papaya, blade, forceps, white sheet of paper.

**HOW DO WE PROCEED?**

1. With the help of a blade, vertically cut a flower (Flower A) of *Petunia*/*Cassia*/*Datura*/*Hibiscus*/lady's finger into 2 halves. Take care not to cut through the pistil of the flower (gynoecium).
2. Spread the 2 halves, side by side, on a white sheet.
3. Observe the various parts of the flowers carefully and compare them with the figure given below (Figs. 26.1, 26.2 & 26.3).
4. identify the parts you observe.

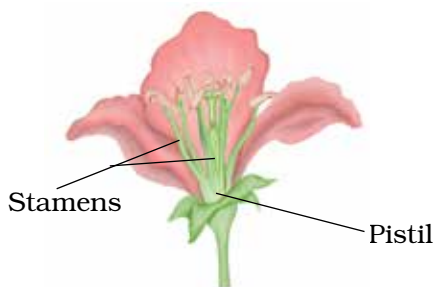

Figure 26.1 Parts of a flower

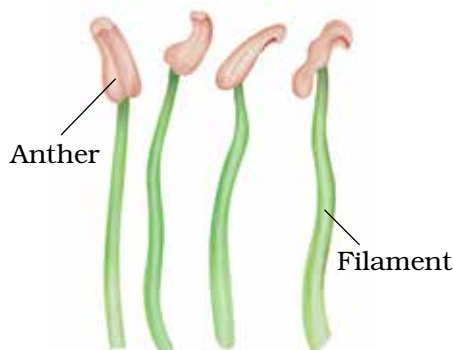

Figure 26.2 Parts of a stamen

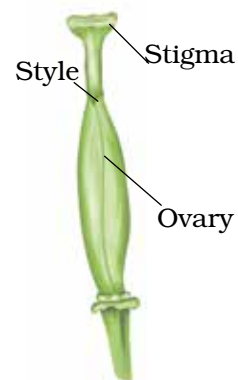

Figure 26.3 Parts of a pistil

5. Pull out the individual parts with the help of forceps, one after another, and group them separately based on their colour and appearance.
6. Take another flower (Flower B) of pumpkin/bitter gourd/snake gourd/papaya and repeat the above steps to observe and identify the parts.



WHAT DO WE OBSERVE?

Flower A has four parts–

- prominent coloured parts
- green-coloured parts surrounding coloured parts at the base.
- a number of filaments in the middle with a yellow-creamish part.
- a centrally located structure with a swollen base.

Write your observations for the flower B as you did for flower A.



WHAT DO WE CONCLUDE?

- The green part of flower is the sepal.
- The large, coloured part is the petal.
- The filamentous part (many in number) with a yellow-creamish part is the stamen.
- The central part (only one in number) with broad base is the pistil.
- Flower A has all the four parts.
- Flower B has only 3 parts—sepals, petals, stamens or pistil.
- As flower A has both stamen (male reproductive part) and pistil (female reproductive part), it is a bisexual flower (*bi* = two).
- Flower B has only one of the reproductive parts – either stamen or pistil. Hence, it is a unisexual flower (*uni* = one).



LET US ANSWER

1. Name the green parts of a flower.
2. Which are the male reproductive parts of the flower? Draw their structure and label them.
3. Name the yellow-creamish part of stamens? What is formed inside them?
4. Write the significance of pistil in flower.
5. Can self-pollination occur in a unisexual flower? Give reasons for your answer.
6. Why do insects and butterflies visit the flowers?
7. Which part of the flower becomes the fruit?



WHAT MORE CAN WE DO?

- Collect 10-12 different kinds of flowers. Divide students into four groups and each group may study the parts of 2-3 kinds of flowers. The Table 26.1 can be filled.

Table 26.1.

S. No	Name of the Flower	Petals		Sepals		No. of Stamens	No. of Pistils
		Number	Colour	Number	Colour		

- Categorise the flowers into unisexual and bisexual flowers. Study various methods of pollination in these flowers. This can clarify the concept of self and cross-fertilisation in flowers.

NOTE FOR THE TEACHER

- Teacher can take the students to the school garden or any nearby garden to show the variety of flowers. Various parts of the flowers can be studied there itself. Students should be told to collect only a few flowers. Plucking too many flowers should be discouraged.
- As the activity involves the use of blade for sectioning the flower, it must be done under supervision of the teacher.

NOTES _____

ACTIVITY 27



WHAT WE HAVE TO DO?

Let us learn about joints in our body and how they move.



WHAT DO WE NEED?

We need enthusiastic, cheerful children!!

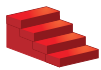

HOW DO WE PROCEED?

The teacher will draw the Table 27.1 on the black board or the Table can be written on sheets of paper and distributed to students. The students may be called in groups and asked to move different body parts which will involve different joints in our body. Students will choose the appropriate type of movement/statement from the list and complete the Table.



WHAT DO WE OBSERVE?

One of the group members will fill up the Table 27.1 on the basis of observations made by the group.

Table 27.1 : Body parts/joints and their movement. Choose from the following and write in column 2 moves sideways, rotates, does not move, moves up and down, rotates partly, bends.

S. No.	Body part/joint	Type of Movement	Type of Joint
1	Head		
2.	Skull		
3.	Lower jaw		
4.	Neck		
5.	Arm (shoulder)		
6.	Elbow		
7.	Wrist		
8.	Finger		

9.	Backbone		
10.	Leg		
11.	Knee		
12.	Ankle		
13.	Toe		
14.	Ribs and Chest		

(Note that the last column (Type of joint) will be filled up later only after a discussion in the class on various types of joints in our body.)



WHAT DO WE CONCLUDE?

After filling the columns in the Table 27.1, we can conclude that:

- Each part listed in the Table is made up of many bones.
- Bones are strong and cannot be bent.
- Our body parts bend only at those points where bones meet.
- The points where bones meet are called joints.
- Different joints exhibit different types of movement.
- Cartilage is present at the ends of bones. (It acts as a smooth surface between bones.)
- Certain muscles are attached to the bones. Bones cannot move by themselves. Bones and muscles function together and enable movement.
- A pair of muscles work together to bring about movements of bones. When one muscle contracts the other relaxes.



LET US ANSWER

1. Which type of joint allows maximum movement in all directions?
2. Which parts of your arm have the following joints:
 - a) Hinge joint
 - b) Gliding joint
 - c) Ball and socket joint
3. We can turn our head from left and right because of
 - a) ball and socket joint
 - b) hinge joint
 - c) pivot joint

4. Match the following:

Column A

- a) Gliding joint
- b) Hinge joint
- c) Fixed joint
- d) Partially movable joint

Column B

- Skull
- Ankle
- Between ribs and breast bone
- Knee

5. Our skull is made up of several plate-like bones which are joined to each other. Like other joints, can these bones also show any kind of movement? Give reason for your answer.



WHAT MORE CAN WE DO?

- Find out from your family members or relatives if they have suffered from any kind of joint-related problem. Also find out the advise given to them by the doctors during such problems in the form of DOs & DON'Ts. Fill up the information in the Table 27.2.

Table 27.2

S. No.	Pain Related to which joint	DOs	DON'Ts

NOTE FOR THE TEACHER

- Before beginning the activity the teacher will assess the class by asking questions on types of movements in various animals.
- Students may refer the textbook for correlating the type of joint with the type of movement.
- During discussion on identifying the types of joints, teacher shall guide the students on the basis of examples as given below.

Type of joint	Type of Movement	Examples

- Ball and socket joint: End of one of the bones is round like a ball. It fits into the socket (hollow part) in the other bone and allows maximum movement in all directions. Joints at hip and shoulder.
- Pivot joint: This joint allows movement in all directions—left and right, up and down. Joint between head and neck.
- Hinge joint: This joint allows movement in one direction only— up and down, or backward and forward, like the hinges of a door. Elbow joint and knee joint.
- Fixed joint (or Immovable joint): The edges of two flat bone at this joint are tightly interlocked in a zipper fashion. Bones of the skull.
- Partially movable joint: This joint allows only partial movement. Joints between the bones of backbone; joints between ribs and breast bone
- Gliding joint: In this joint two bones can slide upon each other. It allows side to side as well as backward and forward movement. Joints between the wrist bones and between the bones of ankle.

ACTIVITY 28**WHAT WE HAVE TO DO?**

Find out what the exhaled air contains.

**WHAT DO WE NEED?**

Two test tubes, two thin glass tubes/plastic tubes/straws (6-8 inch long), lime water, water.

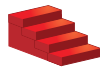
**HOW DO WE PROCEED?**

1. Take two clean test tubes and label them 'A' and 'B'.
2. Half-fill the test tube 'A' with tap water and take the same quantity of freshly prepared lime water in test tube 'B'.
3. Place the glass tube/plastic tube/straw in each test tube, taking care that one end dips properly in the solution.
4. Blow air (exhale) into test tube 'A' for 2-3 minutes. Shake the tube vigorously. Repeat the process 2-3 times and keep it in a test tube stand [Fig. 28.1 (a)].
5. Now, blow air into test tube 'B' for 2-3 minutes. Shake the tube vigorously. Repeat the process 2-3 times and keep it by the side of test tube 'A' [Fig. 28.1 (b)].
6. Observe both the test tubes and compare the colour of solutions in them.

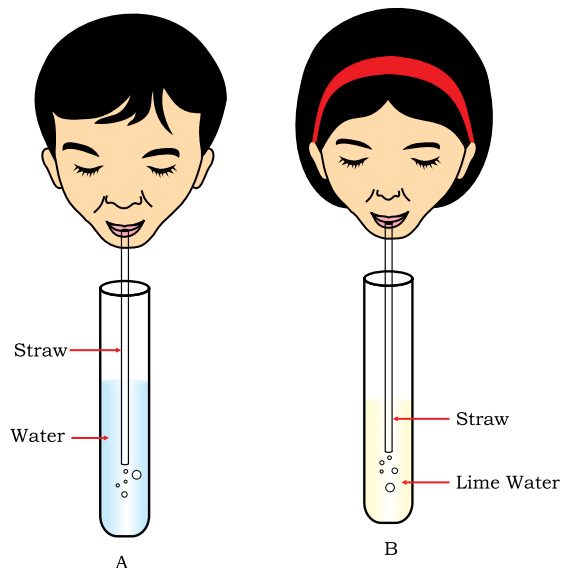

Figure 28.1
(a) Air being exhaled into water
(b) Air being exhaled into lime water



WHAT DO WE OBSERVE?

The colour of water in test tube 'A' remains unchanged whereas the colour of lime water in test tube 'B' turns milky.



WHAT DO WE CONCLUDE?

Exhaled air contains carbon dioxide which turns lime water milky.



LET US ANSWER

1. What is lime water? Write the significance of taking lime water in the experiment.
2. Why does lime water turn milky in test tube 'B'?
3. What is the difference in the inhaled air and exhaled air?
4. Does the exhaled air contain only carbon dioxide?
5. Which gas in the inhaled air is necessary for respiration in human beings?
6. Are there organisms that can respire in the absence of oxygen? Name a few of them.
7. How are photosynthesis and respiration linked to each other?



WHAT MORE CAN WE DO?

- A sensitive indicator called Phenol red can be used in place of lime water. Take a small quantity of water in a test tube (1-2 mL), add 2 drops of Phenol red and shake well. The solution appears pink. If we exhale into the solution, CO₂ present in the exhaled air dissolves in it and the pink solution turns pale yellow.
- Blow air on a mirror. You will find some water droplets on the mirror. This is because exhaled air contains water vapours which condense on the cool surface of the mirror in the form of water droplets.

NOTE FOR THE TEACHER

- Before the start of activity, teacher should explain the concept of breathing and respiration. The students must be familiar with the terms 'inhalation' and 'exhalation'.
- Lime water can be prepared by dissolving lime (calcium hydroxide) in water. Filter the solution and you get lime water.
- Do not blow air in quick short bursts as this may splash the solution out of the test tube.
- Cover the mouth of the test tube with the thumb while shaking.

NOTES _____

ACTIVITY 29**WHAT WE HAVE TO DO?**

Understand the mechanism of breathing.

**WHAT DO WE NEED?**

A wide-mouthed plastic bottle, Y-shaped glass/plastic tube, one-holed cork, balloons, rubber/plastic sheet, rubber band.

**HOW DO WE PROCEED?**

1. Take a wide-mouthed plastic bottle and remove its bottom.
2. Fix a one-holed cork to the mouth of the bottle.
3. Take a Y-shaped glass/plastic tube and fix a deflated balloon to both the forked ends, as shown in the Fig. 29.1.
4. Insert the stem of the tube into the cork in such a way that the forked end is present in the bottle.
5. With the help of a rubber band tie a rubber or plastic sheet onto the open base of the bottle.
6. Pull the rubber sheet from the base downwards and observe the balloons.
7. Now push the rubber sheet upwards into the bottle and observe the changes in balloons.
8. Repeat the above two steps 3-4 times and observe.

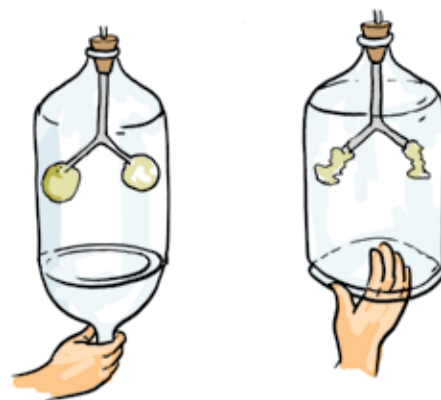

Figure 29.1
Model to show mechanism of breathing

**WHAT DO WE OBSERVE?**

When we pull the rubber sheet downwards the balloons inflate and become larger in size. However, when we push the sheet upwards, the balloons deflate and shrink in size.



WHAT DO WE CONCLUDE?

When we pull the rubber sheet downwards, it increases the space in the bottle. As a result air rushes through the opening of the Y-tube into the balloons, thereby, inflating them. When we push the rubber sheet upwards, the space in the bottle decreases and puts pressure on the balloons, because of which, the balloons push air through the Y-tube and are deflated.

The model used in the above experiment simulates the respiratory system of human beings.

- The plastic bottle represents the chest cavity.
- The stem of the Y-tube represents the wind-pipe which divides into two branches (Bronchi) with forked ends.
- The balloons represent the lungs and the rubber sheet, the diaphragm.

As described in the above activity,

During inhalation

- Diaphragm moves downwards.
- Chest cavity increases in size and air enters the lungs.
- Lungs get filled with air and expand in size.

During exhalation

- Diaphragm moves upwards.
- Chest cavity decreases in size and air is forced out of the lungs.
- Lungs release the air and reduce in size.



LET US ANSWER

1. Differentiate between inhalation and exhalation.
2. What is the role of diaphragm in breathing?
3. What would happen if the diaphragm stops moving?
4. What does the plastic bottle represent in the above activity?
5. Why does the size of the chest cavity changes during inhalation and exhalation?
6. Why should the stem of the tube open outside the bottle?
7. Name the structural unit of diaphragm which helps in its movement.



WHAT MORE CAN WE DO?

- The activity can be performed with a glass tube without any bifurcation.
- Place your hand on the abdomen. Take a deep breath and release it slowly. Note the change in the movement of your abdomen. Now perform the same activity but place your hand on the chest. You can feel the movement of your rib cage.
- Feel the movement of your abdomen and rib cage during breathing in different states such as physical
 - a) During relaxation
 - b) After exercising
 - c) After running

Record the frequency of movement in a minute and give reasons.

NOTE FOR THE TEACHER

Before the start of this activity, the students must be familiar with the terms 'inhalation' and 'exhalation'. A brief discussion about the structure of the respiratory system may be done in the class. Students must be told about the muscular and involuntary nature of diaphragm to understand its movement.

NOTES _____

ACTIVITY 30**WHAT WE HAVE TO DO?**

Observe how water moves between cells in plants.

**WHAT DO WE NEED?**

A medium-sized potato, potato peeler, knife, sugar solution, pins, Petri plate and water.

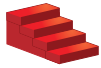
**HOW DO WE PROCEED?**

1. Take a potato and peel off its skin.
2. Make both ends flat by cutting off thin slices with a knife.
3. From one end carefully scoop out a cavity in the potato, leaving a thin layer of potato tissue all around the cavity.
4. Fill half of the potato cavity with sugar solution.
5. Mark the level of sugar solution inside the cavity by inserting a pin into the potato wall.
6. Now place the potato cup in a Petri plate containing water, such that most of the potato cup is dipped in water, but the level of water is lower than that of sugar solution (Fig. 30.1).
7. Keep the set-up for a few hours and observe the level of sugar solution in the cavity.

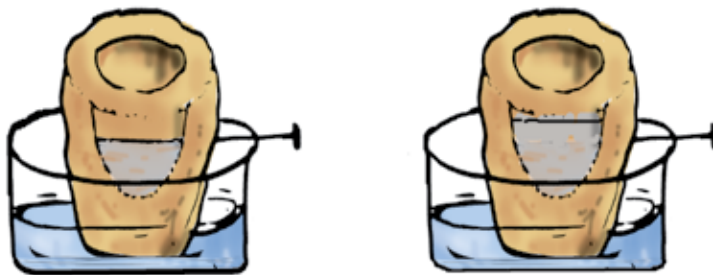

Figure 30.1
Water moves through different cells of potato through osmosis

Precautions

- The wall of the potato cavity should not be more than 4-5 mm thick.

- Take care that the wall remains intact while scooping the potato or while inserting the pin in the wall.
- For marking the level of sugar solution inside the potato cup insert the pin at an angle with its tip coinciding with the level of sugar solution.
- Do not fill the potato cavity with sugar solution up to its brim as it may overflow.
- Take care that the level of water in Petri-plate is lower than the level of sugar solution in the potato cavity.



WHAT DO WE OBSERVE?

After a few hours we will observe that water from the Petri plate enters the potato cavity and the level of solution in the cavity rises.



WHAT DO WE CONCLUDE?

- The Petri plate has higher concentration of water molecules than the potato cavity.
- Water moves from the Petri plate into the potato cup across the cell walls and cell membranes.
- Potato membrane behaves as a semi-permeable membrane through which water moves from its higher concentration to lower concentration. Such movement of water is called osmosis.



LET US ANSWER

1. What is the direction of movement of water in the above experiment? Give reasons.
2. How does water move from soil to the xylem of root?
3. How does water reach from the roots of a plant to the leaves?
4. What would happen in the above experiment if –
 - a) the level of water is higher than that of sugar solution?
 - b) wall of potato is quite thick?
 - c) skin of the potato is not peeled off?



WHAT MORE CAN WE DO?

- Taking all other precautions, set up another experiment but with a hole in the potato cup made with a pin.
- Set up another experiment by reversing the water and sugar solution in the experiment. Observe the level of water in the potato cup after a few hours. What do you conclude?

NOTE FOR THE TEACHER

- Before beginning the activity ask a few recapitulation questions like the examples given below:
 - a. How do plants absorb water and minerals from the soil?
 - b. How do water and nutrients move from roots to the leaves?
 - c. Which tissue is responsible for transport of materials in plants?
 - d. Name the vascular tissue for transport of water and nutrients in plants.
 - e. Name the vascular tissue for transport of food prepared in leaves to all parts of the plant.
- The term osmosis may not be introduced at this stage because the students are not familiar with the concept of molecules, concentration of solutions and selectively permeable cell membrane.
- The teacher may emphasise upon the direction of movement of water and rise in the level of sugar solution bearing in mind the concept of osmosis.

NOTES _____

ACTIVITY 31**WHAT WE HAVE TO DO?**

Study the different types of reproduction in fungi/plants.

**WHAT DO WE NEED?**

A slice of bread, water, filter paper, Petri plate, micro-slide, cover glass, forceps, Compound microscope.

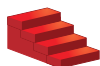
**HOW DO WE PROCEED?**

1. Take a piece of bread and sprinkle some water on it.
2. Place it on a moist filter paper kept in a Petri plate.
3. Leave it undisturbed in a warm but shaded place for two-three days.
4. Observe the surface of the bread slice.
5. You may find some thread-like structures on it (Figs. 31.1 & 31.2). If they are not seen, sprinkle some more water and leave the bread slice for one or two more days.
6. With a forceps, pull out a few threads from the bread slice and place them on a micro-slide.
7. Add three to four drops of water and place a cover glass. Observe under the low power of microscope (Figs. 31.3 & 31.4).



Figure 31.1
Fungus growing on moistened bread

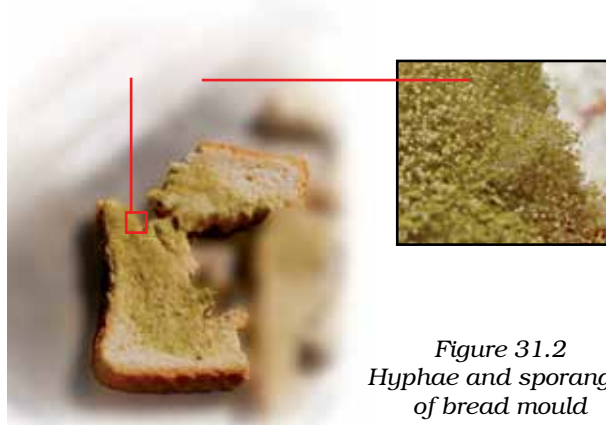

Figure 31.2
Hyphae and sporangia
of bread mould

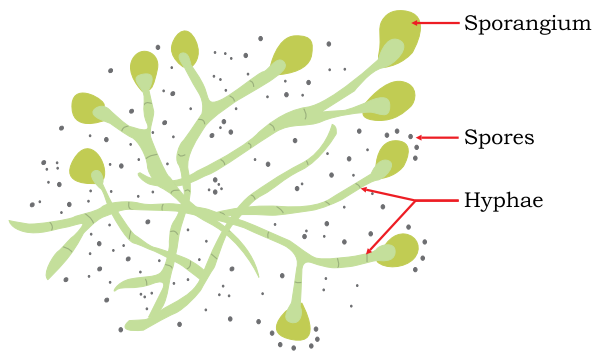

Figure 31.3 Hyphae seen under microscope

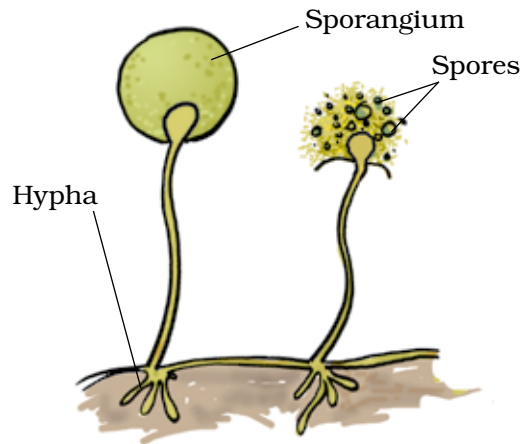

Figure 31.4 Asexual reproductive structures of bread mould



WHAT DO WE OBSERVE?

- The thread – like structures seen on the surface of bread may be green/white/brown/grey–coloured.
- When observed under the microscope, these structures comprise of long thin filaments with spherical/club-shaped bodies at their tips.
- Several small rounded spores will be seen floating in water.



WHAT DO WE CONCLUDE?

- The thread-like structures on the surface of moist bread are the hyphae of a fungus, bread mould a kind of fungus.
- Some hyphae develop a spherical/club-shaped body at the tips called sporangium.
- The sporangium produces several hundreds of minute rounded spores.
- The spores are asexual reproductive bodies which are released into the atmosphere.
- Under certain conditions, spores germinate into new hypae.

Some of the most common fungi are *Penicillium*, *Aspergillus*, *Mucor* and *Rhizopus*.



LET US ANSWER

1. Name the organism that can grow on a moist bread slice.
2. What does bread contain that encourages growth of mould?
3. State whether the following statements are *true* or *false*. If false, correct the statement.
 - a) Fungi are heterotrophs and derive their nutrition from other sources.
 - b) *Rhizobium* is a bread mould which reproduces by spore formation.
 - c) Spores of bread mould are light-weight and can be dispersed easily.
4. Where are spores formed in a fungus and how are they dispersed?



WHAT MORE CAN WE DO?

Plants reproduce in various ways. The following activities can be performed to understand this.

- Take a fresh potato. With the help of a magnifying glass, observe the 'eyes' on its surface. Cut a few pieces of potato with 'eyes'. Sow them in soil and water them regularly for about a week. You will observe the growth of small plants from the pieces of potato tuber (Fig. 31.5). Tuber is a vegetative part. This method of producing new plants from the vegetative parts of plants is called vegetative propagation.

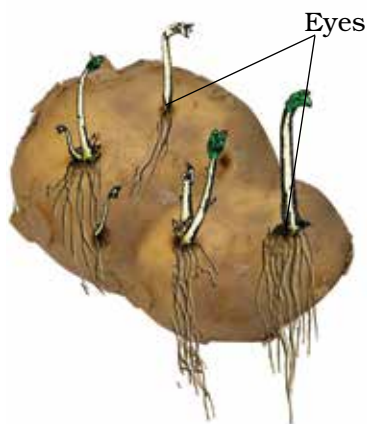

Figure 31.5 Young potato plants emerging from 'eyes' (buds) of potato



Figure 31.6 Young ginger plants growing from the stem of ginger



Figure 31.7 Young plants growing from the leaf of Bryophyllum

- Cut a few pieces of fresh ginger and sow them in the soil. Water them daily and observe after a week. Do you observe any kind of growth (Fig. 31.6)?
- Observe a 'leaf' of the sprouted leaf plant (*Bryophyllum*). You will see small buds in the margins of leaves. Remove a few buds and sow them in the soil. Water them daily for 8-10 days. You will observe young plants growing from these buds (Fig. 31.7).

NOTE FOR THE TEACHER

- Teacher should introduce the concept of asexual and sexual reproduction in plants. The term 'vegetative propagation' may also be explained before performing the activity.
- Students must be strictly cautioned not to eat the bread infected with fungus or inhale the spores. Students may be asked to collect different plants that may reproduce by their vegetative parts.
- Teacher may also give the following project to the students. The students of the class may be divided into four groups. Each group may perform the experiment on bread slice by keeping it in different conditions (see the table below) and record their observations. Students may also plan innovations and perform the experiment.

S.No.	Conditions	Observation
1.	Moist and warm	
2.	Moist and cold	
3.	Dry and warm	
4.	Dry and cold	

Observation : Hyphae seen on day 3/hyphae seen on day 6/hyphae not seen at all.

ACTIVITY 32**WHAT WE HAVE TO DO?**

Study the mode of reproduction in yeasts.

**WHAT DO WE NEED?**

A beaker, warm water, sugar, dehydrated yeast powder, micro-slide, dropper, glass cover (cover slip), Compound microscope.

**HOW DO WE PROCEED?**

1. Take some warm water in a beaker.
2. Dissolve a spoonful of sugar in it.
3. Now add about 1g of dehydrated yeast powder into the solution and stir it.
4. Keep the beaker in a warm place for about an hour.
5. With the help of a dropper, place a drop of the solution on a clean micro-slide.
6. Place a cover glass on it taking care that air bubbles do not enter beneath the cover glass. Observe the slide under the microscope.

**WHAT DO WE OBSERVE?**

- A number of minute, rounded unicellular yeast cells can be observed (Fig. 32.1).
- A few yeast cells have a bulb-like projection on their body.
- Some yeast cells appear like chains of 3-4 cells.

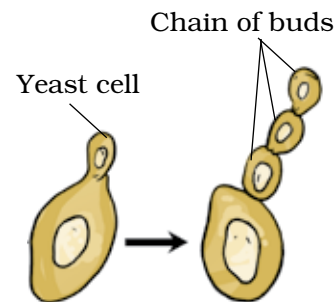

Figure 32.1
Reproduction in yeast by budding

**WHAT DO WE CONCLUDE?**

- Yeasts grow well in a solution containing sugar kept in warm conditions.
- A bulb-like projection develops on the adult yeast cell called the bud.

- The bud grows in size, detaches from the adult cell and forms a new yeast cell.
- Sometimes, buds may remain attached on the yeast cell and another bud may arise from it appearing like a chain of buds.
- This method of asexual reproduction by formation of buds is called budding.

Another organism which reproduces by budding is *Hydra*.



LET US ANSWER

1. What would happen if we conduct the above activity in cold water?
2. Is yeast an autotroph or a heterotroph?
3. State whether the following statements are *true* or *false*. If false, correct the statement.
 - a) Yeast is a fungus that has heterotrophic mode of nutrition.
 - b) Yeast can reproduce by budding and binary fission.
 - c) The buds remain attached to the parent yeast cell and appear like a chain of cells.



WHAT MORE CAN WE DO?

- Observe the permanent slide showing budding in *Hydra* and compare it with the slide of yeast cells.
- Observe the permanent slides of reproduction in other organisms, such as *Spirogyra*, *Amoeba*, *Paramecium*, etc. Note down the type of reproduction you observe in them. Fill the Table 32.1.

Table 32.1

S.No.	Organism	Type of reproduction observed	What you observed?
1.	<i>Amoeba</i>		
2.	<i>Paramecium</i>		
3.	<i>Hydra</i>		
4.	<i>Spirogyra</i>		

NOTE FOR THE TEACHER

- The teacher should introduce the concept of asexual reproduction in plants and animals. Different methods of reproduction in organisms may be explained to understand the observations.
- It should be noted that the activity must be performed with the dehydrated yeast powder and in warm conditions.
- Yeast cells are very minute and cannot be seen under low magnification. Teachers can focus yeast slide under high magnification (10×40 or 10×100) and show it to students.

NOTES _____

ACTIVITY 33**WHAT WE HAVE TO DO?**

Prepare a temporary slide to observe plant cells.

**WHAT DO WE NEED?**

Onion bulb, forceps, blade/scalpel, water, methylene blue, micro-slide, cover glass, microscope.

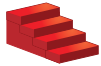
**HOW DO WE PROCEED?**

1. Take an onion bulb and remove its outer dry pink covering.
2. Cut the onion bulb into two halves and take out a fleshy leaf, carefully pull out the thin white peel from its inner surface with a forceps (Fig. 33.1).
3. Cut a small piece of the thin onion peel with a blade/scalpel and place on a clean micro-slide.
4. Add 2-3 drops of water onto the slide and spread the onion peel.
5. Add a drop of methylene blue solution.
6. Carefully place a cover glass on it ensuring that there are no air bubbles under the cover glass.
7. Observe the slide under the microscope.

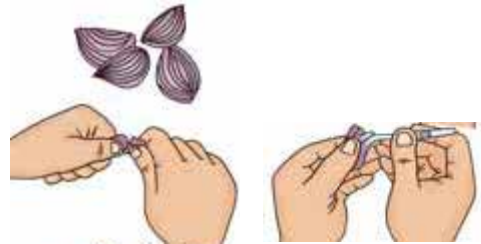

Figure 33.1
Method of removing onion peel

**WHAT DO WE OBSERVE?**

We will observe a number of compactly arranged rectangular cells separated from each other by cell walls. A thin membrane can be observed beneath the cell wall. The cell has a jelly-like substance containing a dense dark-coloured round body (Fig. 33.2).

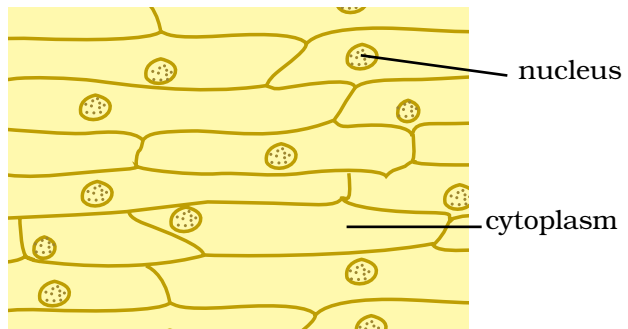

Figure 33.2
A piece of onion peel showing cells



WHAT DO WE CONCLUDE?

- The plant cells are surrounded by the cell wall.
- A thin cell membrane is present beneath the cell wall.
- The cell membrane encloses the jelly-like cytoplasm.
- The cytoplasm has a dense round nucleus which may be located in the centre or slightly on the periphery.



LET US ANSWER

1. Why do onion cells have cell wall? Write the functions of cell wall.
2. Do animal cells have cell wall? Give reasons for your answer.
3. Why do onion peels have a number of cells which are closely packed together?
4. Why is it easier to see onion cells after they are stained with methylene blue?
5. Write the functions of cell membrane and nucleus of a cell.
6. Give reasons for the following:
 - a) Red blood cells are spherical in shape.
 - b) Nerve cells are the longest cells found in human body.
 - c) Muscle cells are elongated and spindle-shaped.
7. Following are the steps for preparation of slide of onion peel.
 - (i) Placing a small piece of onion peel on a micro-slide.
 - (ii) Removing the epidermal peel from an onion bulb.
 - (iii) Adding methylene blue stain to the peel.
 - (iv) Placing the cover glass over the material.

Which of the following represents a correct sequence?

- (a) i, ii, iii, iv; (b) ii, i, iv, iii; (c) iv, ii, iii, i; (d) ii, i, iii, iv.



WHAT MORE CAN WE DO?

- Pluck a fresh and healthy leaf from *Tradescantia/Elodea/Rhoeo* plant. Using a forceps, carefully remove the epidermal peel from them. Perform the experiment as described in the above activity. Observe the leaf peels with or without staining. You will observe similar structure of plant cells as observed in the onion peel along with some new structures, such as stomata.

- Students can make slides using spring onions and record their observations.
- Take a toothpick and gently scrape the inner lining of the cheek with its blunt end. Take care not to hurt your cheek lining. Place the material on a clean micro-slide and spread it. Add a drop of water followed by 2-3 drops of methylene blue solution/iodine solution. Place the cover glass carefully and blot the extra solution if any. Observe the slide under the microscope and draw the observed structures. Note down the differences and similarities between onion peel cells and cheek cells.
- Observe the permanent slides of different animal cells, such as muscle cells, nerve cells, blood cells, etc. Observe the diversity in shape and size of the cells. Relate their shape and size with the functions carried out by them.

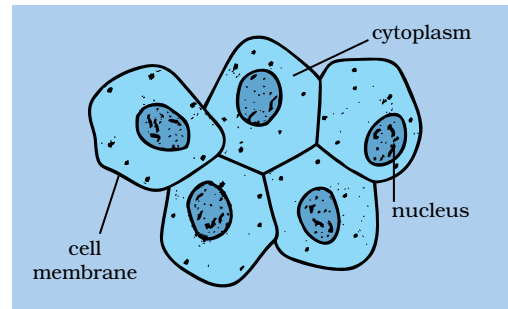

Figure 33.3 Human cheek cells

NOTE FOR THE TEACHER

- Before performing the activity, teacher may explain the concept of a cell as the basic unit of life. Students can be asked to perform the activity in the class individually or in groups and make their observations.
- Since the activity involves use of scalpel/blade, it must be done under the supervision of a teacher. In case the students are performing the activity on cheek cells, they must be told to use blunt ends of the toothpicks and not to hurt their cheeks.

NOTES _____

ACTIVITY 34



WHAT WE HAVE TO DO?

Create awareness among students about sex-based/gender-based discrimination that exists in our society.

Some terms related to the topic:

- The **biological sex** of a person is whether a person is a male or female.
- **Gender** refers to the state of being male or female with reference to social or cultural differences.
- **Gender roles** are perceptions or expectations of how men and women should behave. The views vary from person to person and culture to culture. Since gender roles are created by society, the perceptions of gender role also change with socio-cultural changes.
- **Gender stereotyping** refers to stereotyped images that are associated with males and females. A stereotype is a fixed idea or an image that people may have, but which is often far from reality/truth.
- **Gender-discrimination** is an understanding of the norms and customs of a society which are in favour of one gender over the other and which are practiced in our society since they are passed down from many generations. Understanding the socio-cultural factors responsible for this attitude is essential. This is not meant to defy the societal norms but to critically evaluate such practices.



WHAT DO WE NEED?

Chart papers, bold marker pens, drawing pins.



HOW DO WE PROCEED?

We shall proceed to understand the issue through a series of activities. The activities may involve 'fill-up-the-slip', group-guided discussions, group games, brainstorming – sessions, role plays, skits, poster-making, slogan-writing, using flash cards, under taking case studies, citing anecdotes, setting up a Question box and other such activities.



WHAT WE HAVE TO DO?

34A I am Good.

The activity will increase self-awareness of girls and boys by assessing themselves.



WHAT DO WE NEED?

Slips of paper with the following Table 34.1 for each student.

Table 34.1

S. No.	I am a good student because	I am a good sister/brother because	I am a good daughter/son because	I am a good human being because	I look good because
1					
2					

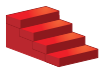

HOW DO WE PROCEED?

1. Fill-up the Table 34.1.
2. Although this is a self-awareness activity, you may share your personal qualities with the rest of the class.



WHAT DO WE OBSERVE?

Each one of us is worthy in one way or the other. We share a good relationship with people we interact with in our daily lives.



WHAT DO WE CONCLUDE?

It is a 'feel good' activity. It sets us in a positive frame of mind, to take up the other activities.



WHAT WE HAVE TO DO?

34B Self-realisation of one's 'strengths and weaknesses'

It will help students to improve their self-awareness and self-esteem which are essential for personality development.



WHAT DO WE NEED?

Slips of paper filled by each student in the previous activity.



HOW DO WE PROCEED?

Exchange the slips filled up in the previous activity with a friend. Discuss whether you have assessed yourself correctly and how can you improve yourself.



WHAT DO WE OBSERVE?

- According to your friend you may have assessed your strengths and weakness correctly/partly correct/absolutely incorrect.
- Similarly, you may feel that your friend is aware/partly aware/not aware about his/her strengths and weaknesses.
- After discussion, you and your friend appreciate each others views, and realise that you may not be completely aware about yourself.
- The activity may increase your self-esteem.



WHAT DO WE CONCLUDE?

Each of us have certain strengths and weakness whether we are boys or girls. Let us appreciate other's strengths and try to correct our weaknesses. Here is an opportunity to enhance our strengths and overcome our weaknesses. It is important to know ourselves better through self-realisation in order to prepare for a normal and meaningful adulthood.



WHAT WE HAVE TO DO?

34C Understanding gender stereotypes.

This will help students understand about the gender-stereotyping by analysing the expected attitude and behaviour of boys and girls in our society.



WHAT DO WE NEED?

Chalk, participatory approach of students.

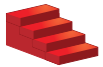

HOW DO WE PROCEED?

1. Have a brain-storming session on the expectation of our society about the behaviour of boys and girls.
2. It can be a group discussion, guided and moderated by the teacher.
3. Teacher can write down the responses of students on the black board.

Expected attitude and behaviour of boys	Expected attitude and behaviour of girls



WHAT DO WE OBSERVE?

Most people have a certain image about the behaviour of boys and girls. For example, the results may reveal that according to our society boys are not expected to cry, always act brave and do outdoor jobs. On the other hand, girls are expected to be weak, emotional, tend to cry easily and are expected to remain indoors.



WHAT DO WE CONCLUDE?

The society have stereotyped the attitude and behaviours of boys and girls. In reality, both, boys and girls experience the full range of

emotions, including happiness and sadness, love and anger, both are mentally strong and enduring in times of crises. Thus, stereotyping a particular attitude and behaviour just on the basis of gender is wrong and unacceptable.



WHAT WE HAVE TO DO?

34D Learning about gender roles.



WHAT DO WE NEED?

Slips of papers.



HOW DO WE PROCEED?

1. Take a slip of paper.
2. Write the sources on the slips from where you have learned about the gender roles discussed in the previous activity.
3. Share it with your classmates and discuss.



WHAT DO WE OBSERVE?

We learn gender roles from sources such as parents, relatives, school, the community, magazines, movies, media, TV advertisements and others.



WHAT DO WE CONCLUDE?

Boys and girls are not born with gender, stereotyped attitudes and behaviours. These are learned in the process of growing up in a society, who influences us in building up gender-fixed roles in our minds. These beliefs are so deeply ingrained in our consciousness that many of us think that gender roles are natural, therefore, we do not question them.



WHAT WE HAVE TO DO?

34E Understand the issue of gender sensitivity.

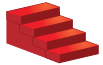

HOW DO WE PROCEED?

Following activities may be carried out to develop gender sensitivity:

1. Enumerating the occupations which are traditionally considered for each gender.
2. Listing down occupations that can be taken up by both genders.
3. Giving examples of famous boys/men or girls/women who have broken stereotype of occupations.
4. Brainstorming session on reasons of gender stereotyping for occupations.
5. A skit on how can these gender stereotypes lead to emotional burden in children.



WHAT DO WE CONCLUDE?

- Different people and cultures have different beliefs about gender roles and responsibilities.
- Both genders can perform complementary roles and are equal to each other in worth.
- We should develop our own critical intelligence about culturally inherited stereotypes. If we see them as attainable goals only then we can bring a change in our society towards gender sensitisation.



LET US ANSWER

1. Why are gender stereotypes destructive for a society?
2. How can gender stereotyping lead to emotional disturbance?
3. How does gender stereotyping limit our potential?
4. Give one example from your own life in which you had/have been affected by these stereotypes?
5. Shouldn't girls play outdoor sports and games?
6. Is it wrong for boys to help their mother in kitchen work?



WHAT MORE CAN WE DO?

- **Activity:** Situation analysis, case studies or anecdotes from newspapers or electronic media which has some examples of gender stereotyping.
- **A question box** can be kept in the class and students can be encouraged to leave slips with queries, confessions, doubts, etc.

NOTE FOR THE TEACHER

- There are several activities that can be performed over the entire year. All the activities are of the participatory type and are required to be performed in groups.
- The activities are so designed that they are expected to dispel myths and misconceptions prevalent in our society, particularly with regard to the girl child. Emancipation from the clutches of such myths is essential for the development of society and the nation at large.
- Teacher should be careful not to single out any individual or group or community, while dealing with such a sensitive issue.
- Teachers should also bear in mind the socio-cultural background of the students involved in performing these activities.
- The teacher should take care that the activities do not create a further divide among students leading to polarisation of views about the gender. The goals should be to dismantle gender stereotyping mind-set and create greater gender sensitivity. The ultimate goal is to establish gender equity.
- The teacher must avoid personal opinions on the issues but should encourage students to express their views open and freely, which means that he/she must not express being judgemental.
- The brainstorming and discussion sessions are meant to encourage students to ask gender-specific questions and use the interactions as a self-reflective tool for image makeover and a mind-set transforming process.
- Students should be encouraged to obtain frank and authentic information from parents, teachers, doctors, counsellor or peers.
- The final discussion session should involve active participation of all the groups finally leading to consensus-building on the debated issue.

THEME**4**

MOVING THINGS, PEOPLE AND IDEAS

ACTIVITY 35

WHAT WE HAVE TO DO?

Measure the length of your classroom by counting the number of steps and to express the length in cm/m.



WHAT DO WE NEED?

A scale (30 cm).

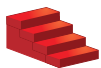

HOW DO WE PROCEED?

1. You will perform this activity in a group of five. Every one of you will measure individually and then compile your results in Table 35.1.
2. Identify one side/wall of your class along which you will measure the length.
3. Measure the length of the room with the help of your foot. Walk along the wall with one foot following the other (without leaving any gap in between the feet). See Fig. 35.1.
4. Count the number of steps.

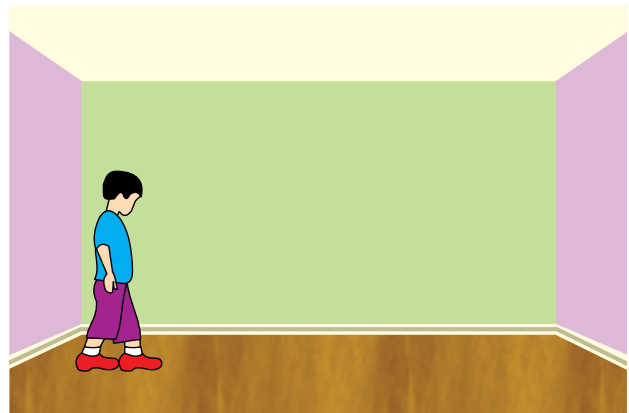

*Figure 35.1
A student measuring the length of a room by walking from one wall to the opposite wall.*

5. Now with the help of the scale measure the length of your foot.
6. Convert the length of the class recorded by you into cm and then in m.
7. Tabulate your data in the following format.

Table 35.1

S.No.	Name	Length of the wall in foot steps	Length of foot in cm	Length of the wall in cm	Length in m
1.					
2.					
3.					
4.					
5.					

- (i) Is the length express in the number of steps by every member of your group the same? If not, then what could be the reason?
- (ii) What can you say about the readings in meters? Are they all approximately equal?
- (iii) Which of the readings will you use to communicate the length of the room to others? Why?



WHAT DO WE OBSERVE

- The length expressed in the number of steps was different for every member of the group.
- When length converted into centimeter or meter, every measurement was almost the same.



WHAT DO WE CONCLUDE?

- Every individual has feet of different length and one cannot communicate or rely upon any measurement using feet, hands, etc.
- One must use standard units (hence the standard instruments) for measuring any physical quantity.



LET US ANSWER

1. It was instructed that while measuring the length with your foot, there must not be any gap in between your feet. Explain the reason.
2. Amit measured the length of a corridor walking straight along the wall and Rehana measured it walking along the wall but going around two chairs which were lying near the wall. Whose measurement will be correct and why?
3. Rewa, whose foot is 22 cm long, recorded the length of the room as 15 foot-lengths and concluded that the room is 4 m long. Is she correct? If not, what is the correct length?
4. Why is it necessary to use standard units of measurement?
5. You were asked to measure the length of your school ground. Which instrument will you use to do this and what precautions will you keep in mind while measuring?



WHAT MORE CAN WE DO?

- Make a scale of folded paper by pasting a strip of a graph paper on it. Using this scale measure the length of your pencil box, textbook, pencil, eraser, your belt, etc.
- Explore the history of measurement and evolution of the standard unit system and make a report on it. Write a script to dramatise it and enact it in front of the class.

NOTE FOR THE TEACHER

This activity can be done in groups. The students may be encouraged to share their observations, discuss and conclude in a team. The teacher may share stories such as that of the French emperor and the first attempt to standardise the unit of measurement. The teacher may make sure that while measuring the students are following the correct procedure. Look at Fig.35.2.

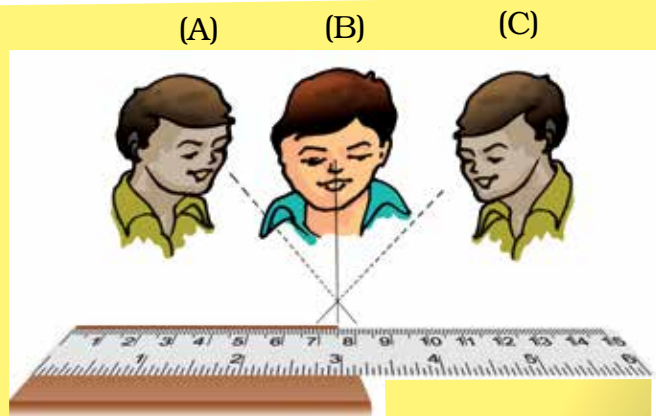

Figure 35.2
(B) is the proper position of eye for taking reading of the scale

ACTIVITY 36



WHAT WE HAVE TO DO?

To find the speed of hopping on one leg.



WHAT DO WE NEED?

A stop watch, a measuring tape or a metre stick



HOW DO WE PROCEED?

1. Draw a long straight line on the ground and a **Start Line**.
2. Draw **Finish Lines** at 20 m, 25 m, 30 m, 35 m and 40 m.
3. If measuring tape is not available, use a meter stick.
4. Choose a partner.
5. Both of you find the least count of the stop watch.
6. Ask your partner to be ready at the START line.
7. Hop on one leg from the START Line to the FINISH Line at 20 m.
8. Ask your partner to note the time taken by you.
9. Repeat this activity for FINISH Lines at 25 m, 30 m, 35 m and 40 m, each time asking your partner to note the time taken by you.
10. Now change places with your partner. You note the time and let your partner hop all the distances.

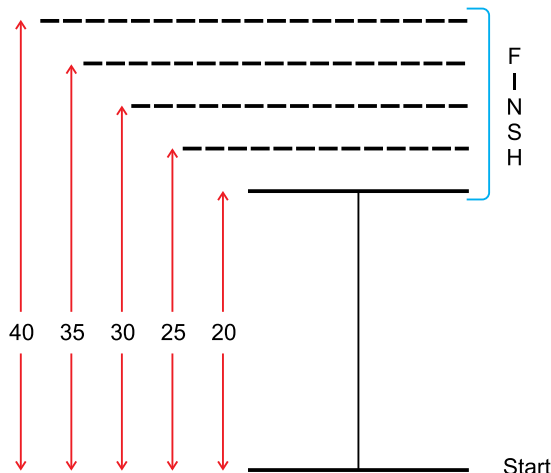

Figure 36.1

Make a Table 36.1 and insert your observations.

Table 36.1

S.No.	Distance (m)	Time taken (s)	Speed = Distance/Time (m/s)
1.	20		
2.			
3.			
4.			
5.			
6.			

Average Speed =

11. Calculate speed for each distance and then the average speed for all distances.
12. Compare your average speed with the speeds calculated by your classmates.
13. Draw a graph of the data you have collected as indicated in Fig. 36.2.

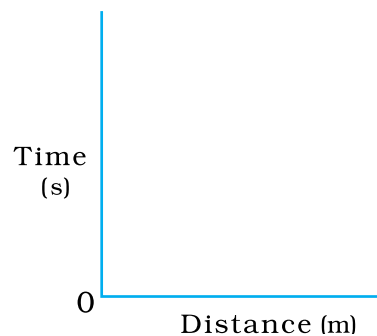

Figure 36.2



WHAT DO WE OBSERVE?

We observe that the time taken for hopping on one leg for various distances was not the same. We calculate the speed for each distance and the average of all speeds. The average speed for each person was different.



WHAT DO WE CONCLUDE?

We conclude that the speed of hopping on one leg is different for different students.



LET US ANSWER

1. What was the least count of the stop watch you used?
2. What precautions did you use in measuring distances?
3. If you used a metre stick, what additional precautions did you take?
4. While hopping, did you move along a straight line? Why is it necessary to do so?
5. In what units did you express your speed? Express your speed in units in which the speed of a bus is usually expressed.
6. A student expresses distance as:
 - (i) 20 m
 - (ii) 20 m.
 - (iii) 20 meter
 - (iv) 20 meters
 Which of these is/are correct expressions?
7. Your partner expressed time as follows:
 - (i) 31 second
 - (ii) 31 sec
 - (iii) 31 s
 - (iv) 31 seconds
 Which of these is/are correct expressions?



WHAT MORE CAN WE DO?

Organise a competition in three-legged race for the class.

NOTE FOR THE TEACHER

- Let students enjoy the game.
- Make sure that students measure distances along a straight line. It is better if a straight line is drawn first and then the distances measured.
- If a meter stick is used, ensure that students mark ends of the stick properly along a straight line and measure from end to end.
- **Possible paths of students**
When students move, note if they stray away from the straight path. If they move along a zig-zag or a curved path (Fig. 36.3), they cover a larger distance than the designated distance, and their actual speed would be higher than that calculated by them.
- **Remember that here we define speed as distance covered/ time taken. This is the average speed. At this stage it is advisable to call average speed as speed.**

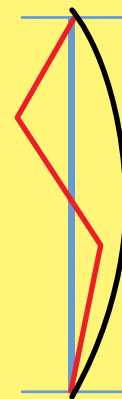

Figure 36.3

- Ensure that students note correctly the least count of the stop watch; otherwise the measurement of time may be incorrect.
- Make students practise conversion of speed from basic units to other units used in daily life such as km/h.
- If students have difficulty in drawing graphs, help them by revisiting the technique of drawing graphs.
- A cellphone may also be used as a stop watch.
- The correct way to express distance is 20 m or 20 meters. Similarly, the correct way to express time is 31 s or 31 seconds.

NOTES

ACTIVITY 37**WHAT WE HAVE TO DO?**

To understand the concept of net force.

**WHAT DO WE NEED?**

A heavy box or an almirah or a heavy table.

**HOW DO WE PROCEED?**

1. Choose a partner.
2. Look for an heavy object in your surrounding.
3. Push the heavy object alone in any direction, say to the right (Fig. 37.1). (The strength of your effort is shown by red arrow.) Can you move it?



Figure 37.1

4. Ask your partner to help you in pushing the object to the right (Fig. 37.2). (The strength of you partner is shown by blue arrow.)

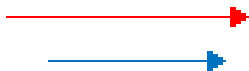

Figure 37.2

5. Ask your friend now to push the object from the opposite side to the left (Fig. 37.3). Has it become easier or more difficult to move the object to the right or left?



Figure 37.3

6. Now both of you push the object to the left (Fig. 37.4). Has it become easier to move the object?



Figure 37.4

7. Now one of you pull it and the other push it in the same direction (Fig. 37.5).



Figure 37.5



WHAT DO WE OBSERVE?

- We observe that when both of us apply force in the same direction by pulling or pushing as in Fig. 37.2, Fig. 37.4 and Fig. 37.5, the object can be easily moved. When both of us apply force in opposite directions as in Fig. 37.3, it becomes difficult to move the object.
- In fact, it is possible to prevent the object from moving at all by applying equal forces in opposite directions.



WHAT DO WE CONCLUDE?

- When forces are applied in the same direction, the total or **net force** is said to be equal to the sum of these forces.
- When forces are applied in the opposite directions, the net force is the difference of the two forces and acts in the direction of the larger force.
- When forces applied in opposite directions have equal magnitudes, the net force is zero.



LET US ANSWER

1. When you and your partner pushed the object in the same direction, did it become easier to move the object? What is the net force in this case?
2. When you and your partner pushed from opposite directions, was it possible to move the object? If yes, in which direction did the object move? What is the net force in this case?
3. When you pulled and your partner pushed, in which direction did the object move?
4. Suppose that you pulled and your partner pushed an object. Draw diagram to show the various situations. What is the net force in each case?
5. In the situation shown in Fig. 37.3, in which direction would the object move?



WHAT MORE CAN WE DO?

- Arrange a tug of war game in the class. Let the students identify directions and magnitudes of forces by observing the direction in which the rope moves.
- If an object does not move on being pulled or pushed, identify the various forces (including the force of friction) acting on it, and their direction. For the force of friction refer to the Chapter on friction.

NOTE FOR THE TEACHER

- The teacher can help students identify the various forces and their directions acting on an object when it is pushed or pulled.
- When the object does not move on being pushed or pulled, the teacher can ask students to identify the forces acting on it. She can use this opportunity to explain the role of the force of friction in opposing the applied force.

ACTIVITY 38**WHAT WE HAVE TO DO?**

To show that liquid pressure depends only upon the height of the liquid column and not the volume of the liquid.

**WHAT DO WE NEED?**

Three to four transparent plastic bottles of different capacities (2 litre, 1.5 litre, 1 litre and 0.5 litre), Nail or compass to make holes in the bottle, Cello tape, Meter scale, Paper cup, a wooden stool or table to be used as a stand, water.

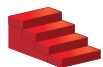
**HOW DO WE PROCEED?**

1. Take three transparent plastic bottles of different capacities.
2. Make one hole on the side of each of the bottle at the same distance from the base of the bottles.(Fig. 38.1)

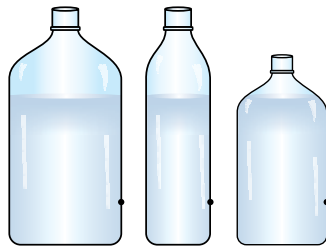

Figure 38.1

3. Seal these holes with cello tape.
4. Make a mark near the top of the bottle of the least height. Measure the height of this mark from its bottom. Make marks at this height in the remaining two bottles too.
5. Fill each bottle with water using a paper cup. Note that the level of water is the same in all the bottles (till the mark made on each bottle). Count the number of cups used to fill each of the bottles.
6. Place one of the bottles on the wooden stool or table. Remove the cello tape from the hole. The water stream will come out of the hole.
7. Mark the point at which the water stream falls on the floor.

8. Measure the distance of this mark from the base of the stand (Fig. 38.2).
9. Repeat the same steps with all the bottles and tabulate the reading in Table 38.1. (Make sure that bottles are placed at the same position on the stool every time).

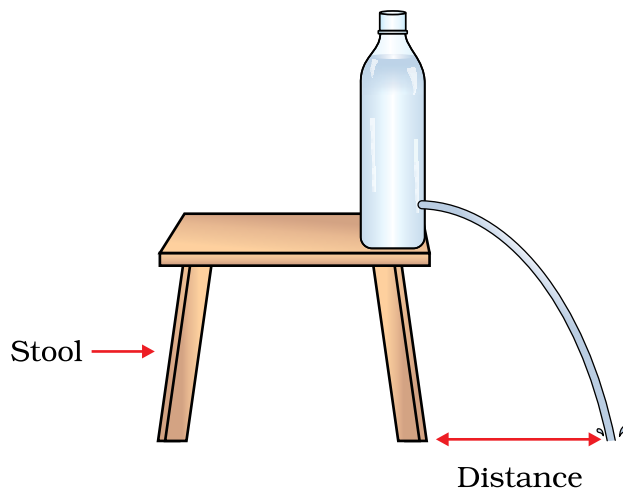

Figure 38.2

Table 38.1

Bottle	Distance of the mark from the stand (cm)

What can you say about the distances recorded by you? Are they approximately equal?



WHAT DO WE OBSERVE?

Though the volume of water in different bottles was different still the distance at which the water stream from the holes hit the ground was almost the same for every bottle.



WHAT DO WE CONCLUDE?

We conclude that the liquid pressure depends only upon the height of the liquid column and not the volume of the water in the container.



LET US ANSWER

1. In the above activity, will you get the same observation if the level of water in each bottle was different?
2. Shyama has two water tanks of equal volume in her house. One is placed on the loft of her kitchen which is on the ground floor and

the other on the terrace of the second floor. The water from which of the tank will come with a greater pressure and why?

3. Observe the two sets of pictures given below and answer the question for each set (Fig. 38.3).

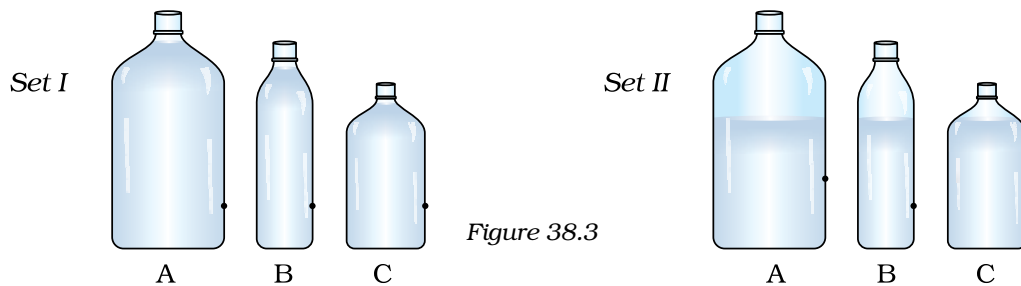

Out of the three bottles, water stream from which bottle will fall the closest from the bottle and why?



WHAT MORE CAN WE DO?

- Take a long plastic bottle. Make three holes at different heights as shown in Fig. 38.4. Seal the holes with one long piece of cello tape. Fill the bottle with water. Place this bottle on a wooden stool or table and remove the tape. Observe the water streams coming out of the three holes. Water stream from which of the holes falls the farthest from the bottle. Give reason.

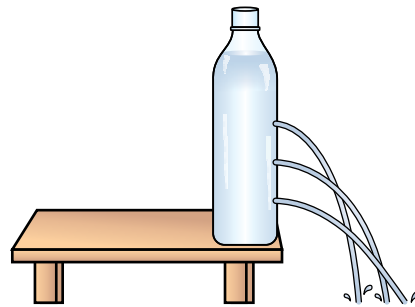

Figure 38.4

NOTE FOR THE TEACHER

- This activity can be done in smaller groups. The students may be encouraged to share their observations, discuss and conclude in a team.
- The containers taken for the activity can be of any shape or size.
- Ensure that the water level in each bottle must be the same and the hole made must be at the same height from the base.
- The distance of the mark where the water stream hits at first needs to be considered every time.

ACTIVITY 39**WHAT WE HAVE TO DO?**

Explain the working principle of a rubber dropper.

**WHAT DO WE NEED?**

A rubber dropper and a beaker with water.

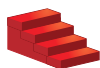
**HOW DO WE PROCEED?**

1. Take a rubber dropper.
2. Press the rubber bulb of the dropper by keeping its nozzle on your finger tip. What do you feel?
3. Immerse this nozzle half into the water in the beaker and press the bulb.
4. Do you see any air bubble escaping the nozzle? Where is this air coming from (Fig. 39.1)?
5. Keeping the nozzle still inside the water, release the bulb. What do you observe?
6. Does it make any difference when you press the bulb harder?

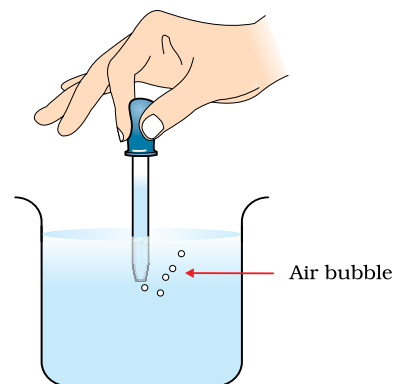

Figure 39.1

**WHAT DO WE OBSERVE?**

- When the rubber bulb is pressed we feel some air coming out of it on our fingertip.
- When the bulb is pressed with the nozzle immersed inside water, air bubbles are seen escaping.
- When the bulb is released, the water from the beaker rushes into the dropper.
- When the bulb is pressed harder and released, large amount of water is filled in the dropper.



WHAT DO WE CONCLUDE?

When the bulb is pressed, air from the nozzle of the dropper escapes from it and partial vacuum is created inside the nozzle. When the bulb is released, water rushes into the nozzle to fill this vacuum. This is because of the air pressure on the surface of water in the beaker (Fig. 39.2).

The harder we press, the larger the amount of air that is pushed out and greater the vacuum that is created. As a result more water is pushed in.

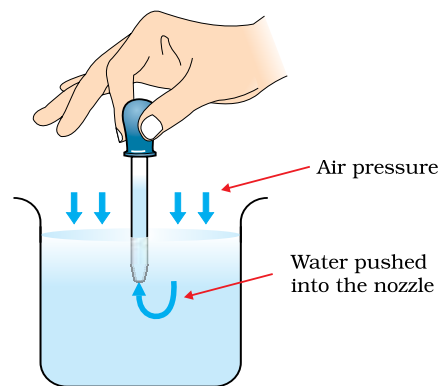

Figure 39.2



LET US ANSWER

1. While drinking milk-shake with the help of a drinking straw, how does the milk rise up inside the straw?
2. Is there any similarity between the working of a syringe and the working of a rubber dropper?



WHAT MORE CAN WE DO?

- Make a 'Pichkari' out of a thin plastic bottle using this principle.
- You have a tank full of water. One way to take water out of it is to use a rubber pipe. Explain how you would draw water from the tank.

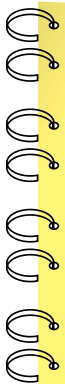

NOTE FOR THE TEACHER

- Children may have the wrong notion that it is the pressure of water that is responsible for pushing water inside a dropper. This activity should also be used to dispel this notion.
- It is the principle of siphon that is used for transferring water from the water tank to a bucket.

NOTES _____

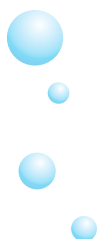

ACTIVITY 40**WHAT WE HAVE TO DO?**

To show that the increase in weight will increase the static friction between two surfaces.

**WHAT DO WE NEED?**

A wooden block with a hook (a nail can be fixed to the block and used as a hook), a medium sized (8-10 cm long) soft rubber band, some weights e.g., 1/2 kg, 1 kg, 2 kg, etc. and a meter scale.

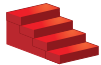
**HOW DO WE PROCEED?**

1. Take the wooden block with the hook.
2. Tie the rubber band to the hook.
3. Place the block along a meter scale as shown (Fig. 40.1).

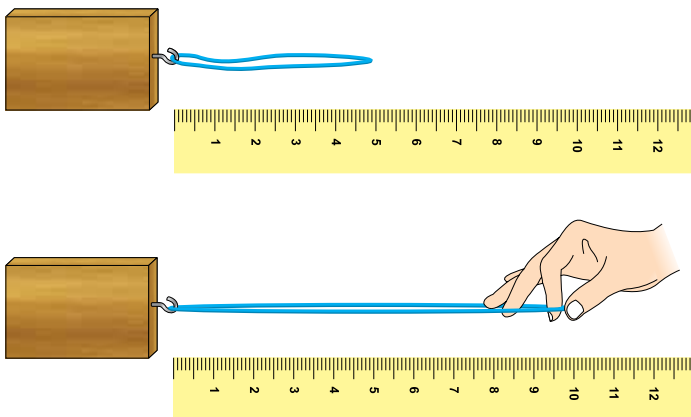

Figure 40.1

4. Try to pull the block.
5. Measure the length of the stretched rubber band when the block just start to move.
6. Put $\frac{1}{2}$ kg weight on the block and repeat the same step again. Measure the length of the stretched rubber band.
7. Now put 1 kg weight and 2 kg weight one by one and measure the length of the stretched rubber band, when the block just start to move.

8. Record your observations in the Table 40.1.

Table 40.1

Mass of the weight placed on the block (kg)	Length of the stretched rubber band (cm)
0	
1/2	
1	
2	

9. What can you say about the lengths recorded by you? Is there any relation between the amount of weight put on the block and the stretching of the rubber band?
10. Draw a graph between the weight and the length of the stretched rubber band (Fig.40.3).

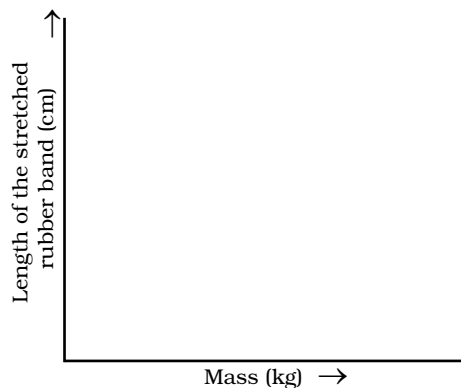

Figure 40.3



WHAT DO WE OBSERVE?

- The force required to pull the block increases with the increase in the weight on the block.
- The length of the stretched rubber band is proportional to the weight put on the block. The graph between the length of the stretched rubber band and the weight is almost a straight line.



WHAT DO WE CONCLUDE?

The interlocking of the irregularities between the surfaces of the block and the table increased when the surfaces were pressed harder by putting weight on the block. Hence, the static friction increases with the increase in weight.



LET US ANSWER

1. In the above activity what changes will you make to move the block easily.
2. A pile of book is lying on a table. When will the pile experience the force of friction?
3. Is there any type of friction acting in the following cases? If yes name the type of friction:
 - (i) A heavy box pushed by a person, which does not move.
 - (ii) An object moving with a constant speed.
4. Why does it become difficult for a rickshaw puller to pull the rickshaw when three people are sitting on it compared with the situation when only one person is sitting on it?



WHAT MORE CAN WE DO?

- Take a durry (mat) and try to pull it. Now ask one of your class mates to sit on the durry and try to pull it again. Repeat this activity with ten of your class mates. Arrange them in the order of increasing effort required by you to pull the durry with them sitting on it. Now confirm whether your estimation is correct by asking them their mass.

NOTE FOR THE TEACHER

- This activity can be done in pairs. The students may be encouraged to share their observations, discuss and conclude in a team.
- The students must be told that the force of friction between two surfaces comes into action only when some force is applied to move an object over the other. Static friction is the force of friction just before the sliding or rolling takes place.

THEME

5

HOW THINGS WORK

ACTIVITY 41



WHAT WE HAVE TO DO?

Make a bulb glow with the help of a few cells and a few pieces of wire.



WHAT DO WE NEED?

A few dry cells, an LED, connecting wires, safety pins, a few drawing pins, a piece of thermocol, a piece of thick cotton connecting wire, a candle, a match box and cello tape.



HOW DO WE PROCEED?

For making a switch:

1. Fix one end of a safety pin on the piece of thermocol with the help of a drawing pin.
2. Fix another drawing pin on the thermocol in such a way that the free end of the safety pin touches it when brought closer to it. This setup can be used as a switch as shown in Fig. 41.1.

For making the circuit:

3. Take three pieces of connecting wires. Remove the plastic covering from the ends of each of the three wires.



Figure 41.1 A simple switch

4. Join one end of a wire with the positive terminal of the cell and fix it with the help of cello tape.
5. Join the other end of this wire with one leg of the LED.
6. Take the second piece of wire. Join one of its ends with the other leg of the LED. Fix the other end of the wire to the drawing pin on the switch made by you.
7. Take the third piece of wire and join one of its end to the negative terminal of the cell and the other end to the second drawing pin of the switch (Fig. 41.2).
8. Has the LED started glowing? Is the path for the flow of current complete? Is there any gap left in this arrangement? Is there air in this gap?
9. Now touch the free end of the safety pin with the second drawing pin. Does the LED glow now?
10. Detach the safety pin from the second drawing pin.
11. Drop a few drops of wax on this drawing pin. Now touch the free end of the safety pin with this wax coated drawing pin. Does the LED glow again?
12. Detach the safety pin and remove the wax from the drawing pin. Replace any piece of wire in the set up with a thick cotton thread. Now complete/close the circuit. Does the LED glow now?



Figure 41.2 An electric circuit with a switch



WHAT DO WE OBSERVE

- (i) The path for the current is closed when the free end of the safety pin is attached to the second drawing pin and the LED starts glowing.
- (ii) The LED does not glow when the switch is closed with the wax coated drawing pin.
- (iii) The LED did not glow when one of the wires was replaced by the cotton thread.



WHAT DO WE CONCLUDE?

- The LED glows when the path for the current gets completed (or the circuit is completed). Materials like metals which allow electric currents to pass through them are called conductors of electricity.

- The insertion of things like wax or cotton thread breaks the circuit and do not allow the current to flow. The LED did not glow in those cases. Substances like plastic, wax, rubber which do not allow the current to pass through them are called insulators.



LET US ANSWER

- Why did the LED not glow when the free end of the safety pin was not touching the drawing pin? What was there in between the safety pin and the drawing pin which prevented the LED to glow?
- How does the bulb of a torch glow when two or three cells are inserted in it? Draw the path of the current passing through the torch.
- Amrita's torch was not working. She bought new cells and inserted them in the torch but the torch bulb still did not glow. Explain the possible reasons.
- Will the order in which the bulb, cell and switch are connected in the circuit affect the passing of current?



WHAT MORE CAN WE DO?

- Try to light a bulb with a cell and one piece of wire.
- Take two cells and arrange them in a circuit as shown in Fig. 41.3. In which of the cases will the bulb glow and why?

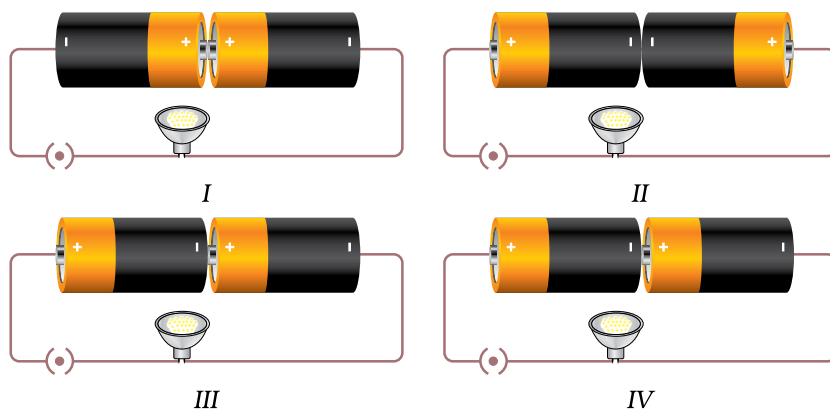

Figure 41.3

- Look at the bulb closely and draw a diagram and label every part of it.

NOTE FOR THE TEACHER

- This activity can be done in groups. Explain to students that every material can conduct electricity under certain conditions and hence we name the material which do not allow current to pass through them as poor (or bad) conductors. The teacher may give the example of lightning through air to elaborate that air does conduct electricity under certain conditions.
- Encourage children to arrange the components of the circuit in different ways changing their order every time. The teacher may draw circuit diagrams on the blackboard to help the students.

NOTES _____

ACTIVITY 42**WHAT WE HAVE TO DO?**

To make a magnet out of the given iron nail and observe its properties.

**WHAT DO WE NEED?**

A few iron nails about 5 cm long, a bar magnet, a circular piece of thermocol (about 6 cm in diameter), a large mug with water, a few pins.

**HOW DO WE PROCEED?**

1. Take an iron nail. Place it on the table.
2. Bring the north pole of the magnet near the head of the nail.
3. Touch the head of the nail with the magnet and drag the magnet along the surface of the nail till the other end.
4. Now lift the magnet and bring the same pole near the head of the nail and repeat the above action.
5. Repeat this process 30-40 times.
6. Bring this nail near a few pins. See if the pins get attracted towards the nail.
7. If the pins are not getting attracted, rub the nail with the magnet a few more time.
8. If the pins are now getting attracted your magnet is ready. You may also call it as nail magnet.
9. Fix this magnet on to the circular thermocol piece with a tape.
10. Place this setup in the mug full of water and swirl it.
11. When the thermocol comes to rest, notice the direction in which the nail is pointing.
12. Swirl the magnet five to six times and notice the direction in which the nail points every time it comes to rest. This direction is the magnetic north-south direction. Can you relate the direction of the nail with any geographical direction?

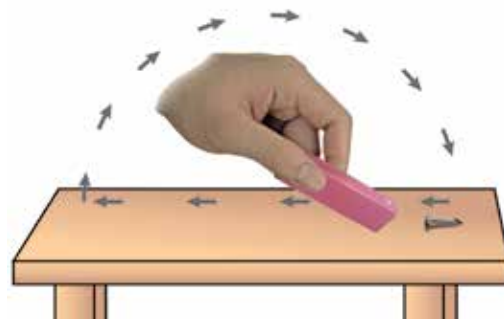

Making your own magnet



A compass in a cup

13. The pole pointing to the north direction is called the north pole. Mark this pole of the magnet with red paint.
14. Bring the north pole of the magnet, near the north pole of the nail magnet.
15. What did you observe? Does the nail magnet get deflected? If yes, note the direction of this deflection.
16. Now, once the nail magnet comes to rest, bring the south pole of the magnet near the north pole of the nail magnet. In which direction did the nail magnet deflect now?



WHAT DO WE OBSERVE?

- The nail magnet comes to rest every time in the same direction which corresponds to the magnetic north-south direction.
- When the south pole of a magnet is brought near the north pole of the nail magnet, it gets attracted.
- When the north pole of the magnet is brought closer to the north pole of the nail magnet, it gets repelled.



WHAT DO WE CONCLUDE?

- A piece of iron can be made into a magnet by rubbing it repeatedly with a magnet.
- A freely rotating suspended magnet always points in the north-south direction.
- Like poles of two magnets repel each other and unlike poles attract each other.



LET US ANSWER

1. Test the magnet made by you after a week and see if it retains its properties.
2. If the magnet made by you is mixed with other similar looking nails, how will you detect your magnet?
3. A sailor has to move towards east direction. How can he use the magnet to find this direction?



WHAT MORE CAN WE DO?

- Try to make a magnet out of a nail made of aluminium or brass. Did you succeed?
- Take a piece of paper. Mark your own position at the centre of it. Now show the direction of the Principal's office, the school ground, the science lab and the school canteen with the help of a magnet.
- Take a fresh nail. Repeat steps 2-5, but this time take the south pole of the magnet for rubbing. Now determine the north pole of this nail magnet. Compare the poles of this magnet with the poles of the magnet you made earlier. Can you relate the poles of a nail magnet with the pole of the magnet you used for rubbing?

NOTE FOR THE TEACHER

- Try to make a magnet out of a nail made of aluminium or brass. Did you succeed?
- Take a piece of paper. Mark your own position at the centre of it. Now show the direction of the Principal's office, the school ground, the science lab and the school canteen with the help of a magnet.
- Take a fresh nail. Repeat steps 2-5, but this time take the south pole of the magnet for rubbing. Now determine the north pole of this nail magnet. Compare the poles of this magnet with the poles of the magnet you made earlier. Can you relate the poles of a nail magnet with the pole of the magnet you used for rubbing?

NOTES _____

ACTIVITY 43**WHAT WE HAVE TO DO?**

To find out whether both the poles of a magnet are equally strong and whether all magnets are equally strong.

**WHAT DO WE NEED?**

We need a few magnets (say 3-4) of different lengths, few pins (say 15-20) made of iron or steel of equal size, a scale, cello tape.

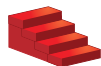
**HOW DO WE PROCEED?**

1. Fix a meter scale on a table with cello tape.
2. Mark magnets as 1, 2, 3, 4.
3. Place magnet-1 along the scale at a fixed point.
4. Place a pin at a distance of about 5 cm from the magnet as shown in Fig. 43.1. Observe what happens. Is the magnet able to attract the pin?
5. Move the pin gradually towards the magnet in small steps. Keep on observing carefully. Is there a point at which the pin is just pulled towards the magnet?
6. Note down this distance of the pin from the magnet in Table 43.1.
7. Now reverse the end of the magnet so that its other pole is facing the pin.
8. Repeat the above steps and note down the distances at which the pin is just pulled towards the magnet.
9. Repeat all the above steps using magnet-2, magnet-3, etc.

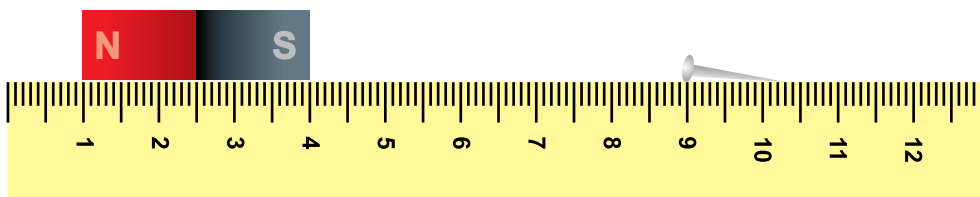

Figure 43.1



WHAT DO WE OBSERVE?

Table 43.1

Magnet No.	Pole facing the pin	Distance at which the pin is pulled towards the magnet (cm)	Tick the correct box
1	N S	d_1 d_2	$d_1 = d_2$ <input type="checkbox"/> $d_1 \neq d_2$ <input type="checkbox"/>
1	N S	d_1 d_2	$d_1 = d_2$ <input type="checkbox"/> $d_1 \neq d_2$ <input type="checkbox"/>
1	N S	d_1 d_2	$d_1 = d_2$ <input type="checkbox"/> $d_1 \neq d_2$ <input type="checkbox"/>
1	N S	d_1 d_2	$d_1 = d_2$ <input type="checkbox"/> $d_1 \neq d_2$ <input type="checkbox"/>

- Do you observe that the distances d_1 and d_2 are equal for both poles of all the magnets?
- Are the distances d_1 and d_2 measured for all the four magnets equal?
- If these distances are not equal, what could be the reason?



WHAT DO WE CONCLUDE?

- In each magnet distances d_1 and d_2 are equal. It shows that both the poles (North pole and South pole) of each magnet are equally strong.
- If distances d_1 and d_2 are not equal for all magnets, it means that the magnets are not equally strong.
- All magnets may or may not be equally strong. Moreover, the strength of a magnet does not depend on its size.



LET US ANSWER

1. Najma observed that a pin is pulled towards a magnet. Which property of the magnet is shown by her observation?
2. Magnet A is able to pull the pin at a distance of 4.0 cm. Magnet B is able to do so as a distance of 3.0 cm. Which magnet is stronger?
3. Magnet A is stronger than magnet B. Which of these will be able to pull the pin from a shorter distance?



WHAT MORE CAN WE DO?

- You can repeat this activity using magnets of different shapes and sizes.
- Repeat this activity by replacing magnet with a sharpener, an eraser and a pencil. Report your conclusions.

NOTE FOR THE TEACHER

- As far as possible children should use pins of the same size and fresh pins every time.
- Instruct children to remove all other magnets and all objects made from magnetic materials from the table where they are working. It may affect their observations.

A game can we played by two teams at a time.

Take several iron-shoe nails or ½-inch screws. Place 10 of these at equal distances from one



Figure 43.2

another on a smooth surface with their heads down (Fig. 43.2). Take care that the distance between the nails/screws is as small as possible, but they should not touch each other. A member of a team places a magnet at a distance of about 10 cm from the nails/screws. She moves the magnet towards the nails/screws gradually so that only one nail/screw is attracted. The idea is to develop skill so that only one nail/screw is attracted without disturbing the others. The team which is able to attract all the ten nails/screws in the least amount of time will be declared the winner.

ACTIVITY 44**WHAT WE HAVE TO DO?**

To observe the heating effect of electric current.

**WHAT DO WE NEED?**

2 D type 1.5 V cells, cell holder, Plug key/switch, nichrome wire of about 20 cm length, a candle.

**HOW DO WE PROCEED?**

1. Take about 20 cm long nichrome wire. Wrap it over a candle uniformly so that each turn is separate from the other. Now you have made a coil with the candle as its core.
2. Connect any one end of this wire with the positive terminal of the battery and complete the electric circuit as shown in Fig. 44.1.
3. Insert the key in the plug. The electric circuit is closed now.
4. Observe the candle for a few minutes. Does it start to melt around the wire?

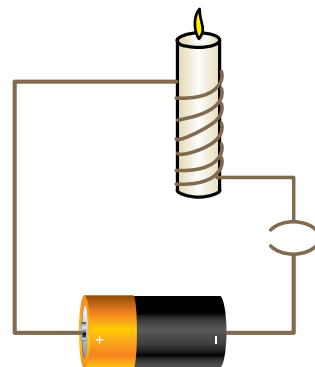

Figure 44.1

**WHAT DO WE OBSERVE?**

- Melting of wax around the wrap produces pattern over the candle.

**WHAT DO WE CONCLUDE?**

- Electric current produces a heating effect in the wire. Hot wire causes the wax to melt.



LET US ANSWER

1. Name three appliances where heating effect of electric current is desirable.
2. Name three electric appliances where heating effect of electric current is undesirable.



WHAT MORE CAN WE DO?

- The activity may be repeated with wires of different lengths/materials.
- Activity may be repeated using 3V battery in the circuit. This new observation may be compared with the activity performed using 9V battery in the circuit. Students may repeat this activity with 1.5V, 3V, 4.5V batteries and report their observations.
- Discussion may be initiated with students on the following points:
 - Does the heat produced in the wire depend on its length?
 - Does the heat produced depend on the material of the wire?
 - Does the heat produced depend the number of cells used?

NOTE FOR THE TEACHER

- A D type cell is a size of drycell. These cells are typically used in high current applications, such as large flashlights, radiorecivers. etc. It is cylindrical with electrical contacts at each end. The positive end has a nod a bump.
- Current should not be passed in the circuit for long duration.
- Care should be taken that students do not touch the wire when circuit is closed as it may hurt them.
- This activity can also be given as a project work to students. They may study various factors on which heating effect of electric current depends. These factors could be the length, thickness and material of the wire and the number of cells used. However, the presence of the teacher is necessary for conducting this activity/project.

ACTIVITY 45**WHAT WE HAVE TO DO?**

To observe how the strength of an electromagnet depends upon the number of turns of the wire.

**WHAT DO WE NEED?**

10 cm long three iron bolts, enamelled copper wire 5 m, a battery of 2 cells, a switch, shoe nails (black iron nails) about 100g, plastic pipe (10 cm), and paper.

**HOW DO WE PROCEED?**

1. Make three electromagnets with 20, 40 and 60 turns. For this wind the enamelled copper wire tightly around the iron bolt in the form of a coil.
2. Rub the free ends of the wires of each electromagnet with the sand paper to remove the enamel coating.
3. Connect the electromagnet with 20 turns to a battery of 2 cells through a switch as shown in Fig. 45.1.
4. Place some shoe nails near the end of the bolt and switch on the current. What happens? Do the nails cling to the bolt? Count the number of nails attracted by this electromagnet.
5. Switch off the current. Now the coil loses most of its magnetism. A few nails may still cling to the electromagnet.
6. Repeat this activity with other electromagnets of 40 and 60 turns with the same set-up.
7. Wind 60 turns of the enamelled copper wire around a plastic pipe instead of an iron bolt and observe if it acts as an electromagnet. Note the number of iron nails it attracts.

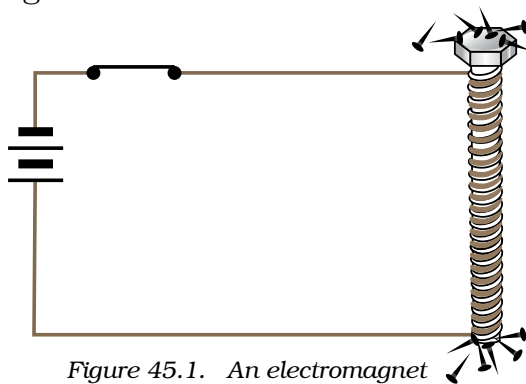

Figure 45.1. An electromagnet



WHAT DO WE OBSERVE?

- The electromagnet loses its magnetism when the electric current is switched off.
- Number of nails attracted by the electromagnet having 40 turns is larger than the number of nails attracted by the electromagnet having 20 turns. Also the number of nails attracted by the electromagnet having 60 turns is larger than the number of nails attracted by the electromagnet having 40 turns.
- Number of nails attracted by the electromagnet with the plastic pipe core was much smaller than when the electromagnet had iron bolt as the core.



WHAT DO WE CONCLUDE?

- A current carrying coil of wire wrapped around a piece of iron works as an electromagnet.
- The strength of an electromagnet depends upon the number of turns of the wire and the core used to make the electromagnet.



LET US ANSWER

1. If you wind an enamelled copper wire around a plastic pipe does it act as a magnet?
2. If we use a plastic pipe instead of the iron bolt, is the magnetic effect as strong as with the iron bolt? Which one of them makes a stronger magnet?
3. List uses of electromagnets.
4. How will you change the strength of an electromagnet without changing the battery provided to you?



WHAT MORE CAN WE DO?

- Repeat this activity by replacing the battery of two cells by a battery of three cells. Do you find any change in the strength of the electromagnet?
- Study the use of electromagnets in some toys available in the market.
- Try the above activity using various iron materials.

ACTIVITY 46**WHAT WE HAVE TO DO?**

Study electrolysis of water.

**WHAT DO WE NEED?**

Water in a 250 mL beaker, common salt, a battery of 3 D type 1.5 V cells, cell holder, double cotton covered copper connecting wires, a switch.

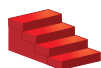
**HOW DO WE PROCEED?**

1. Take two long dcc (double cotton covered) copper wires and fold one end of each into U-shape as shown in Fig 46.1.
2. Fill the beaker about half with water. Add half a teaspoonful of common salt to water to make it more conducting.
3. Insert the U-shaped connecting wire in water. Connect its other end to the positive terminal of the battery.
4. Connect the negative terminal of the battery to a plug key.
5. Connect the second U-shaped connecting wire to the negative terminal of the cell through the key.
6. Insert the key into plug. Wait for a few minutes.
7. The wire connected to the positive terminal of the battery is called the positive electrode and the wire connected to the negative terminal of the battery is called negative electrode.
8. Observe carefully. Do you observe gas bubbles on the electrodes? On which electrode do you observe larger number of bubbles?
9. Now remove the key from the plug. Do you still observe the bubbles on the electrodes?

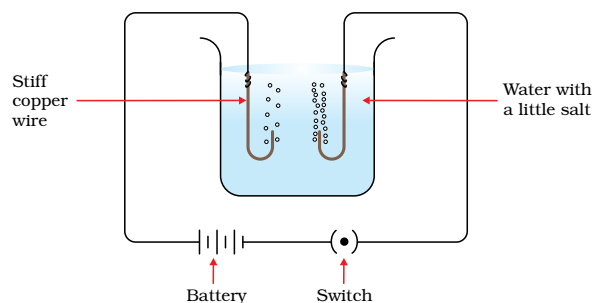

Figure 46.1

**WHAT DO WE OBSERVE?**

- We observe that small bubbles are formed on both the electrodes.
- Smaller number of bubbles are formed on the electrode connected to the positive terminal of the battery. Larger number of bubbles are

formed on the electrode connected to the negative terminal of the battery.

- Bubbles are formed on the electrodes as long as the key remains inserted in the plug.



WHAT DO WE CONCLUDE?

- The passage of an electric current through water causes chemical reaction. As a result bubbles are formed on the electrodes. This is due to the chemical effect of electric current.
- Water molecule (H_2O) has hydrogen and oxygen atoms. When electric current is passed through water, oxygen bubbles are released at the positive electrode and hydrogen bubbles are released at the negative electrode.
- As water molecule has two hydrogen atoms for every oxygen atom, larger number of bubbles are formed at the electrode connected to the negative terminal of the battery.



LET US ANSWER

1. In this experiment, why do we add common salt to water?
2. How can you capture the gas released at both the electrodes?
3. How will you confirm that hydrogen gas is released at the negative electrode?



WHAT MORE CAN WE DO?

- Bubbles released on the electrodes can be collected in a small (glass/ plastic) bottle inverted over the electrodes.
- The distance between the electrodes can be increased and its effect on the number of bubbles released at the electrodes can be studied.
- The activity may be repeated taking water from various sources (tap water, distilled water, river water, etc.) and also by taking electrodes of different materials.

NOTE FOR THE TEACHER

- Care should be taken to avoid excessive flow of current through the circuit. For this a proper resistance may be connected in the electric circuit.
- Keep the two electrodes completely immersed in water.

THEME**6**

NATURAL PHENOMENA

ACTIVITY 47

WHAT WE HAVE TO DO?

Study how shadows are formed.



WHAT DO WE NEED?

A torch (source of light), a circular piece of wood, a sheet of butter paper/tracing paper, a transparent glass sheet/cellophane sheet and a white screen(any white sheet can also be used as a screen).

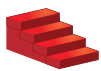

HOW DO WE PROCEED?

1. Take the circular piece of wood.
2. Place a screen on one side of the wooden piece or position the wooden piece in front of a wall.
3. Throw light on the wooden piece with the help of a torch. The surface of the wooden piece must be parallel to the surface of the screen/wall (Fig. 47.1).

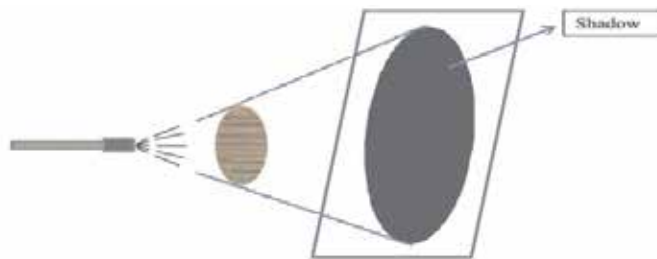

Figure 47.1

4. What do you find on the screen?
 - (i) Do you see a dark patch?
 - (ii) Is the light from the torch reaching on every part of the screen?
 - (iii) If not then on which area is the light getting blocked and what is blocking the light?
 - (iv) Is there any shape being formed on the screen?
5. Now switch off the light. Can you still see the dark patch on the screen?
6. Now switch on the torch but remove the screen.
7. Do you still see the dark patch on the screen?
8. Repeat the above steps, first using a sheet of tracing paper and then a transparent glass sheet in place of the wooden disc and record your observations.
9. Compare the observations made by you in all the three cases.



WHAT DO WE OBSERVE

- When the light is thrown on the wooden piece with a screen behind it, whole of the screen does not light up.
- The circular wooden piece is blocking the light from falling on a certain area on the screen, hence forming a dark circular patch on the screen.
- If the torch is switched off the dark patch disappears provided there is no other light in the room.
- If the screen is removed no dark patch is seen.
- When a tracing paper is used a hazy patch is formed.
- When a transparent glass sheet is used in place of the wooden block, no clear patch can be obtained on the screen (Fig. 47.2).

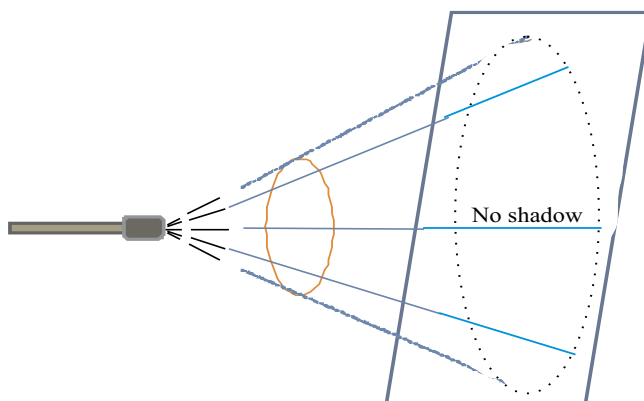

Figure 47.2

A Shadow formed by a transparent object.



WHAT DO WE CONCLUDE?

- The dark circular patch formed on the screen is because the wooden disc is blocking light in that circular region. This region is called a shadow.
- The essential requirements for obtaining a shadow are a source of light, an opaque object and the presence of a screen.
- A transparent glass sheet allows most of the light to pass through it hence no clear shadow is formed.



LET US ANSWER

- 1 When the screen is removed no shadow is seen. Does the absence of shadow imply that the light is not being blocked by the wooden piece.
- 2 What will happen to the size of the shadow when
 - (i) the torch is moved closer to the wooden piece without changing the distance between the wooden piece and the screen,
 - (ii) the torch is moved away from the wooden piece without changing the distance between the wooden piece and the screen, and
 - (iii) when the wooden piece is moved closer to the screen or the wooden piece is moved away from the screen, keeping the distance between the torch and the wooden piece constant?
- 3 Why can't we see the shadow of a bird flying high in the sky?
- 4 Suppose there is a lot of dust on the piece of transparent glass. Will a shadow be formed on a screen when light falls on it? Explain.
- 5 Can the shadow of a circular object be of any other shape than that of a circle? Give example to explain your answer.



WHAT MORE CAN WE DO?

- Opaque objects form dark shadows. Use opaque objects of different colours to cast shadows. Does the shadow formed have any colour?
- When we stand in the Sun we get our shadow in the direction opposite to that of the Sun. Do we also get shadows when we stand in the shade of a tree? Discuss.

- Develop a script/story. Make cutouts of the characters and narrate the story through shadow puppets.

Are eclipses or transits of Venus also shadows? Make a report on eclipses or transits by collecting data.

NOTE FOR THE TEACHER

- This activity can be done in pairs or groups of four children each. The teacher should encourage students to observe keenly, respond to every question, and record observations individually.
- Encourage them also to discuss their observations. The teacher may facilitate the discussion and help the students to arrive at the desired results.
- The teacher may explain that eclipses are the shadows of the moon on the earth (Solar Eclipse) or of the earth on the moon (Lunar Eclipse). Also explain what happens during transit of Venus. She can also explain why we do not see transit of Saturn or Jupiter.

NOTES _____

ACTIVITY 48**WHAT WE HAVE TO DO?**

Show that air exerts pressure.

**WHAT DO WE NEED?**

Plastic bottle, hot and cold water.

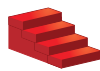
**HOW DO WE PROCEED?**

1. Take a soft plastic bottle.
2. Fill it half with hot water.
3. Empty it and immediately cap the bottle tightly.
4. Now pour ice cold water over this bottle.
5. What do you observe?

**WHAT DO WE OBSERVE?**

The plastic bottle gets deformed when cold water is poured over it (Fig.48.1).

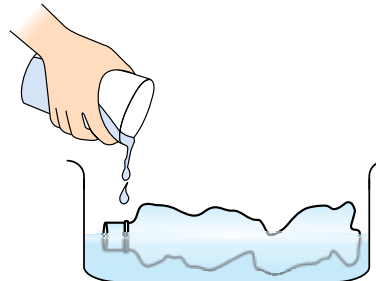

Figure 48.1

**WHAT DO WE CONCLUDE?**

When we fill the bottle with hot water and empty it, the air inside the bottle becomes hot. When cold water is poured over it, this hot air becomes cold and pressure inside the bottle decreases. The pressure of air outside being higher, crushes the bottle.

**LET US ANSWER**

1. In the above activity, if the bottle is not capped immediately after the hot water is emptied, will the same effect be seen? Explain.
2. Mention two more examples which show that air exerts pressure.

3. A plastic bottle filled half with water is placed inside a refrigerator for an hour. When it is taken out it is observed that the bottle is slightly deformed. When left outside the refrigerator for a few minutes the bottle recovers its shape. Explain.



WHAT MORE CAN WE DO?

Encourage children to perform some activity which shows that the boiling point of water depends on air pressure.

Suggested Activity:

Take a conical flask and fill it half with water. Boil this water. Once the water starts boiling, remove the conical flask from the heat and cap it tightly. Once the boiling stops, pour some cold water on the conical flask. What do you observe?

NOTE FOR THE TEACHER

- Any activity involving heating must be done in your presence or in the presence of an elder person.
- Used cans of soft drinks can also be used to demonstrate that air exerts pressure. The metallic can need to be heated for doing this activity.
- Students must be encouraged to cite many examples showing the presence of air pressure.
- Use good quality conical flask for the suggested activity.
- When cold water is poured over the flask containing hot water, some steam gets condensed and the pressure inside decreases. At lower pressure, water boils at lower temperature. If the temperature of water is still higher than its decreased boiling point, the water will start boiling again.

ACTIVITY 49**WHAT WE HAVE TO DO?**

Observe that air expands on heating.

**WHAT DO WE NEED?**

Two plastic mugs, an empty plastic bottle (1/2 litre or 200 mL), a balloon, cold and hot water.

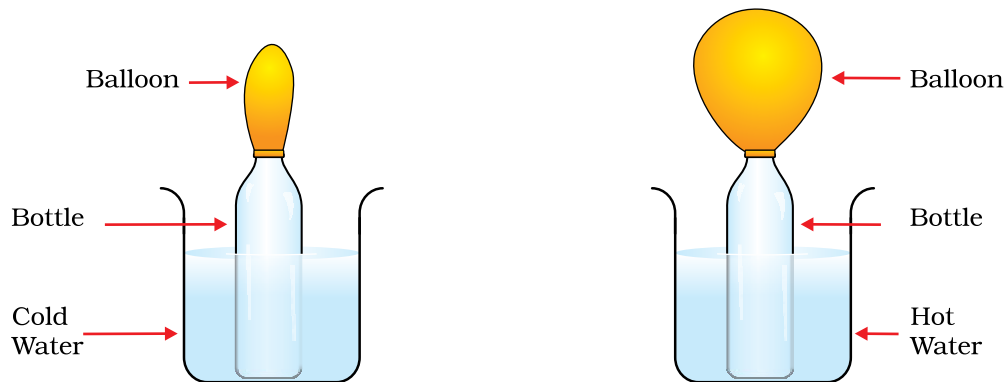
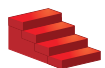

Figure 49.1

**HOW DO WE PROCEED?**

1. Inflate the balloon slightly and fix it on the mouth of the bottle tightly with a thread (Fig. 49.1). (It is advisable to inflate and deflate the balloon a few times.)
2. Pour hot water in one mug and cold water in the other mug.
3. Place the bottle with the balloon in cold water.
4. Observe the size of the balloon.
5. Transfer the bottle now to the mug containing hot water.
6. Observe again the size of the balloon.
7. Transfer the bottle back to cold water and observe the size of the balloon once again.



WHAT DO WE OBSERVE?

- We observe that in cold water, the balloon gets deflated.
- We observe that in hot water, the balloon gets inflated.



WHAT DO WE CONCLUDE?

- There is air inside the empty bottles. When the bottle is kept in hot water the air inside it gets heated. It expands and inflates the balloon.
- In cold water, the air in the bottle contracts and the balloon is deflated.
- In general, air expands on heating and contracts on cooling.



LET US ANSWER

1. Abida is standing in front of a heater holding an inflated balloon. After some time the balloon explodes. Explain why it exploded.
2. John bought a bottle of a water. He drank about 2/3rd of that water and stored the remaining water in a refrigerator. He took the bottle out after 2 hours. He found that the bottle is deformed. Explain the reason.



WHAT MORE CAN WE DO?

Take an empty plastic water bottle. Fill it with ice cold water. Empty it completely and fill it again with a little water. Make a solid paper ball and fit it in the mouth of the bottle. Keep the bottle in the sun for some time. Observe what happens. Explain your observations.

NOTE FOR THE TEACHER

- The bottle should be kept stationary and vertical inside the mug by holding it properly.
- Handle hot water with care.

ACTIVITY 50**WHAT WE HAVE TO DO?**

To observe the image of a candle flame formed by a concave mirror when the candle is placed at different distances from the mirror.

**WHAT DO WE NEED?**

A mirror stand, a concave mirror (focal length about 15-20 cm), a screen with a stand (about 20 cm × 15 cm), a candle, match box, a scale for measuring distances.

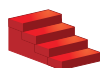
**HOW DO WE PROCEED?**

1. Find the approximate focal length of the concave mirror by focussing sun light on a sheet of paper.
2. Fix the concave mirror on the stand and place it on a table.
3. Keep a lighted candle on the table at a distance of about thrice the focal length of the mirror (say at about 60 cm in front of the mirror if the mirror is of 20 cm focal length).
4. Also, keep the screen on the table. Ensure that the screen does not obstruct the light from the candle falling on the mirror.
5. Try to obtain the image of the flame on the screen. For this move the screen forward, backward and sideways till a sharp image of the flame is obtained.

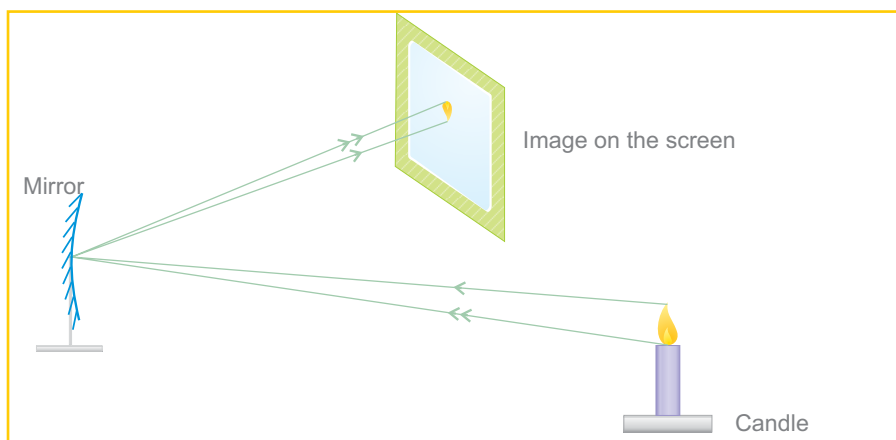

Figure
50.1



WHAT DO WE OBSERVE?

- Observe the size of the image in each case.
- Is the image of the same size as the flame?
- Is the image larger or smaller than the flame?
- Can you get the image on the screen in all cases?
- Measure the distances of the candle and the image of the candle flame from the mirror.
- Now move the candle towards the mirror and place it at distances mentioned in Table 50.1. In each case try to obtain the image of the candle flame on the screen. For this you may have to change the position of the screen (Fig. 50.2).

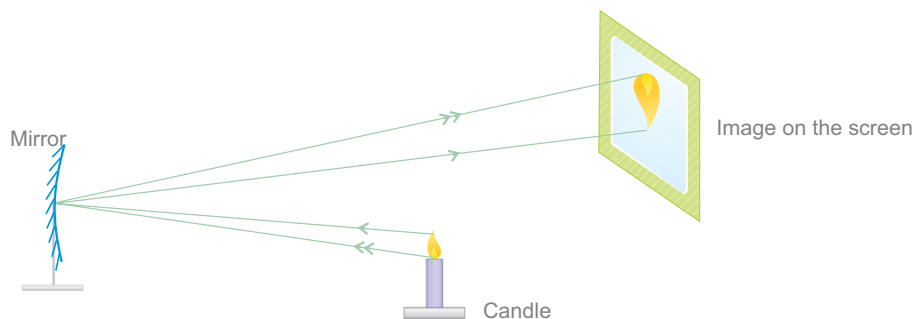

Figure 50.2

Table 50.1

Image formed by a concave mirror for an object placed at various distances from it

Distance of the object from the mirror	Distance of the image from the mirror	Image smaller/	Character of the image larger than the object
			Inverted/erect
60 cm			
40 cm			
30 cm			
20 cm			
10 cm			



WHAT DO WE CONCLUDE?

- We conclude that the image formed by a concave mirror can be smaller or larger in size than the object.
- As the object is moved towards the mirror. The image moves away from the mirror.
- We also see that when the candle flame is too close to the mirror (at distances lesser than the focal length) its image is erect and larger in size than the candle flame itself. This image is however not formed on a screen. It is a virtual image. We therefore conclude that the image formed by a concave mirror may be real or virtual.



LET US ANSWER

1. Place a lighted candle at a distance of 50 cm in front of a concave mirror of focal length 15 cm. Will the image formed be larger, smaller or of the same size as the candle flame?
2. Is it possible to obtain the image of a candle flame on the screen when the candle is too close to the mirror? Try.
3. What in the nature and size of the image when an object is placed too close to the mirror?



WHAT MORE CAN WE DO?

- Repeat the above activity using a convex mirror in the place of a concave mirror. Record your observations in a Table similar to Table 50.1.
- List the uses of concave and convex mirrors in your everyday life.

NOTE FOR THE TEACHER

- Help the students to recognize mirrors used as side mirrors in scooters, reflectors in torches and the mirrors used by dentists.
- If you do not have a mirror stand, you can make one from a piece of the thermocole or from clay or plasticine. In a similar manner you can make a stand for the screen.
- If the object is placed at the focus of the mirror, then the image is formed at infinity. In this situation you will simply see a patch of light on the screen.

ACTIVITY 51**WHAT WE HAVE TO DO?**

Observe the image of a candle flame formed by a convex lens when the candle is placed at different distances from the lens.

**WHAT DO WE NEED?**

A lens stand, a convex lens (focal length of about 15-20 cm), a screen with a stand (about 20 cm × 15 cm), a candle, match box, a scale for measuring distances.

**HOW DO WE PROCEED?**

1. Find the approximate focal length of the convex lens by focusing sun light on a sheet of paper.
2. Fix the convex lens on a stand and place it on a table.
3. Keep a lighted candle on the table at a distance of about thrice the focal length of the lens (say at about 60 cm in front of the lens if the lens is of 20 cm focal length).
4. Try to obtain the image of the candle flame on the screen placed on the other side of the lens. For this move the screen forward, backward or sideways till a sharp image of the flame is obtained.

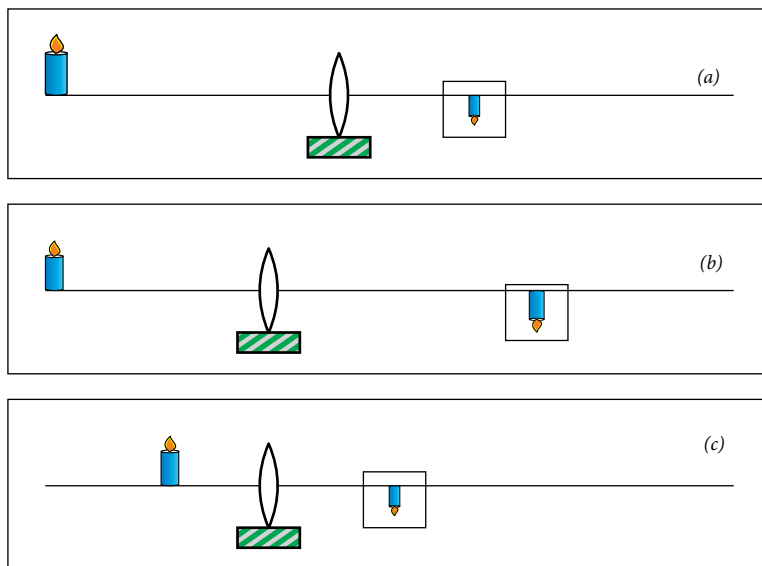

Figure 51.1

5. Measure the distances of the candle flame and its image from the lens.
6. Now move the candle towards the lens and place it at distances mentioned in Table 51.1. In each case try to obtain the image of the candle flame on the screen. For this change the position of screen (Fig. 51.1(b) and (c)) as necessary.

Table 51.1

Image formed by a convex lens for an object placed at various distances from it

Distance of the object from the lens	Distance of the image from the lens	Image smaller/larger than the object	Character of the image larger than the object	
			Inverted/erect	Real/Virtual
60 cm				
40 cm				
30 cm				
20 cm				
10 cm				

- Did you get in any position of the object an image which was erect and magnified? Could this image be obtained on the screen? Is this image real or virtual? This case is shown in Fig. 51.2.



Virtual image formed by the convex lens

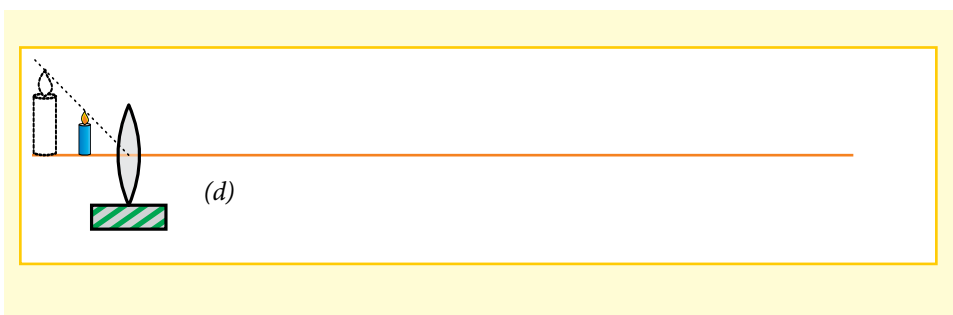
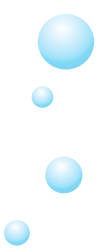

Figure 51.2





WHAT DO WE OBSERVE?

- For the first three cases an inverted image is obtained on the screen.
- The image of the flame becomes bigger as the candle is moved towards the lens.



WHAT DO WE CONCLUDE?

- As the object moves towards the lens the image moves away from the lens.
- The image formed by a convex lens can be smaller or larger in size than the object.
- We also see that when the candle flame is too close to the lens (say at distances lesser than the focal length) its image is erect and larger in size than the candle flame itself. It is a virtual image. So, we conclude that the image formed by a convex lens may be real or virtual.



LET US ANSWER

1. Is it possible to obtain the image of a candle flame on the screen when the candle is too close to the lens? Try.
2. What is the nature and size of the image when an object is placed
 - (i) Too close to the lens.
 - (ii) Quite far from the lens, say at 70 cm.



WHAT MORE CAN WE DO?

- Repeat the above activity using a concave lens in place of a convex lens. Record your observations in a Table similar to Table 51.1.
- List the uses of lenses in your day-to-day life.

NOTE FOR THE TEACHER

- Help the students to observe the uses of lenses in microscopes, telescope, spectacles and other optical instruments.
- If you do not have a lens stand, you can make one from a piece of thermocole or from clay or plasticine. In a similar manner you can make a stand for the screen.
- If the object is placed at the focus of the lens, then the image is formed at infinity. In this situation you will simply see a patch of light on the screen.

NOTES _____

ACTIVITY 52**WHAT WE HAVE TO DO?**

To burn a candle in a glass full of water. (Fun game)

**WHAT DO WE NEED?**

A small shoe box, a small candle, a match box, a clear glass sheet (about 25 cm × 20 cm), a glass tumbler full of water, a wooden or thermocole stand to keep the glass sheet in vertical position.

**HOW DO WE PROCEED?**

1. Take a shoe box open on one side.
2. Place a small lighted candle in the shoe box as shown in Fig. 52.1.
3. Place the glass sheet in front of this candle in a vertical position facing the open end of the shoe box.
4. Stand in front of the glass sheet on the side of the shoe box.
5. Try to locate the image of the candle behind the glass sheet.
6. Place a glass full of water at the position of the image of the candle.
7. Do you observe the candle burning inside water?
8. Measure the distances of the candle and the glass tumbler of water from the glass plate.
9. Try obtaining the image of the candle on a screen.

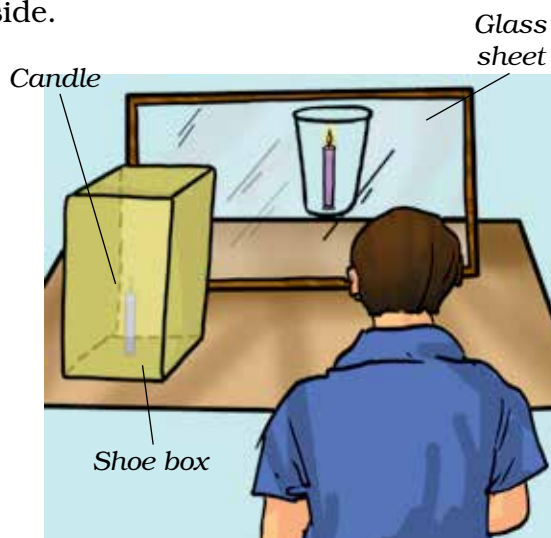

Fig. 52.1
Candle burning in water



WHAT DO WE OBSERVE?

- You will be surprised to see the candle burning in water.
- We could not get the image of the candle on the screen.



WHAT DO WE CONCLUDE?

- We find that the image of the candle is at the same distance behind the glass plate as that of the candle in front of it.
- Here, the glass plate partially acts as a plane mirror. Therefore, we conclude that the image formed by a plane mirror is at the same distance behind the mirror as the object is in front of it.



LET US ANSWER

1. State any two characteristics of the image of the candle formed by the glass sheet.
2. How does the candle appear burning in water?
3. Can we use a plane mirror sheet instead of plane glass sheet to perform this activity?



WHAT MORE CAN WE DO?

- We can use a clear plastic sheet instead of a glass plate. Try this activity with a plastic sheet or a thick transparency sheet.
- Try this activity with a doll. Can you see the image of the doll through the glass plate? Now throw light on the doll with the help of a torch. Can you see the image of the doll now? Explain your observation. Discuss with your friends and teacher.

NOTE FOR THE TEACHER

- Teachers should explain to the students how a clear glass sheet behaves as a plane mirror. Instruct children to clean the glass sheet properly.
- Discuss with the students why we can't use a plane mirror to perform this activity.
- Explain to children that the burning candle seen in water is an optical illusion.

NOTES _____

ACTIVITY 53**WHAT WE HAVE TO DO?**

To verify the laws of reflection.

**WHAT DO WE NEED?**

A plane mirror strip, a few knitting needles/bicycle spokes, a few sheets of chart paper.

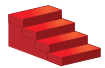
**HOW DO WE PROCEED?**

1. Take two small rectangular pieces of thermocole. Make slits in them and fix a plane mirror. Make sure that the mirror is vertical (Fig. 53.1).
2. Draw a line at an angle of about 45° to the mirror such as AO. Place a knitting needle on this line such that one of its ends touches the mirror (Fig.53.2).
3. Look at the image of the knitting needle in the mirror. Place another needle in line with this image. At the end of this needle mark a point such as B.
4. Remove the mirror and the needles and join point B with O.
5. At O draw a line ON perpendicular to the mirror. This is called the normal to the mirror.
6. Measure angle AON. This is called the angle of incidence.
7. Measure angle BON. This is called the angle of reflection.
8. Are they equal?
9. Repeat the activity twice by placing the needle at different angles.
10. Record your data in Table 53.1.

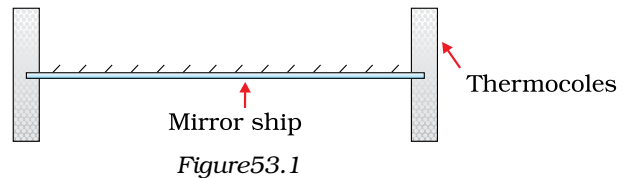

Figure 53.1

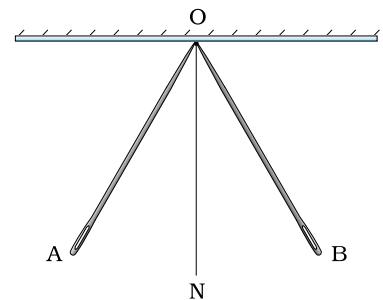

Figure 53.2

Obs. no.	Angle of incident $\angle i$	Angle of reflection $\angle r$	Is $\angle i = \angle r$?	
			Yes	No
1			<input type="checkbox"/>	<input type="checkbox"/>
2			<input type="checkbox"/>	<input type="checkbox"/>
3			<input type="checkbox"/>	<input type="checkbox"/>



WHAT DO WE OBSERVE?

- We observe that the angle of incidence is equal to the the angle of reflection in each case.



WHAT DO WE CONCLUDE?

- The knitting needle placed on the line AO represents the incident ray.
- The knitting needle placed on line BO represents the reflected ray.
- Angle of incidence is equal to the angle of reflection.



LET US ANSWER

- If the incident ray is along the normal, what would be the angle of reflection.
- The reflected ray is at an angle of 80° . What would be the angle of incidence?
- The surface of a mirror is distorted as shown in Fig. 53.3. Name the points on it where the law of reflection will be valid.
- In Fig. 53.4. find the angle of reflection

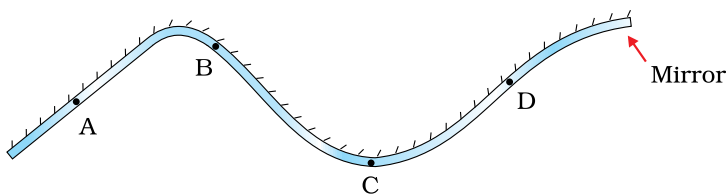

Figure 53.3

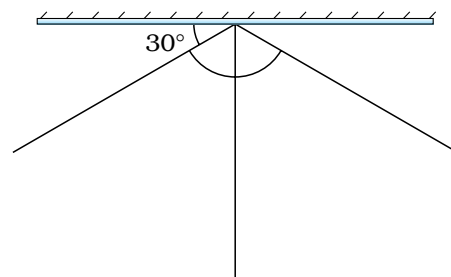

Figure 53.4



WHAT MORE CAN WE DO?

- In Fig. 53.2, place the needle initially along BO and find the reflected ray.
- Show that anyone of AO or BO can be considered as the incident ray. The other then becomes the reflected ray.
- Perform this Activity with pencils instead of the knitting needles (Fig. 53.5). Describe the problems faced by you and how you solved them.

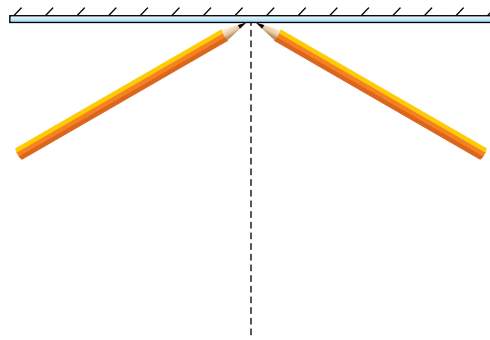

Figure 53.5

NOTE FOR THE TEACHER

- The path of light is completely reversible. Therefore, any ray can be thought of as the incident ray and the other become the reflected.
- When the Activity is performed with thick objects like pencils, their thickness presents the problem of drawing the incident and the reflected rays. Incident ray may be drawn on any side of the object and the corresponding reflected ray is drawn using the same side (Fig.53.5).

NOTES _____

ACTIVITY 54**WHAT WE HAVE TO DO?**

To observe that the appearance of the moon changes every night.

**WHAT DO WE NEED?**

A big ball, black and white paints, brush for painting, 5 m long thick thread, two large size nails.

**HOW DO WE PROCEED?**

1. Take the big ball and paint half of it white and half black (Fig. 54.1).
2. Go out in the playground with some of your friends.
3. Fix a nail on the ground and with the help of the thread, draw a circle of radius about 4 m on the ground (Fig. 54.2).
4. Divide the circle into eight equal parts.
5. Stand at the centre of the circle to represent the earth.
6. Ask another friend to hold the ball at different points of the circle to represent the different positions of the moon in its orbit around the

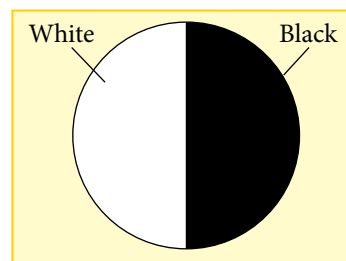

Figure 54.1



Figure 54.2



Figure 54.3

earth. Ask her to keep the white portion of the ball always facing the Sun (Fig. 54.3). If you are performing this activity in the morning then the white portion of the ball should be kept towards the east. If the activity is being performed in the afternoon then the white portion of the ball should be kept towards the west. However, in each case the line dividing the white and black portion should be kept vertical.



WHAT DO WE OBSERVE?

- When you stand at the centre of the circle, observe the visible white portion of the ball while your friend stands at different points marked on the circle with the ball.
- Draw the shape of the white portion as you see it.
- Compare your drawings with the different phases of the moon as shown in Fig. 54.4.

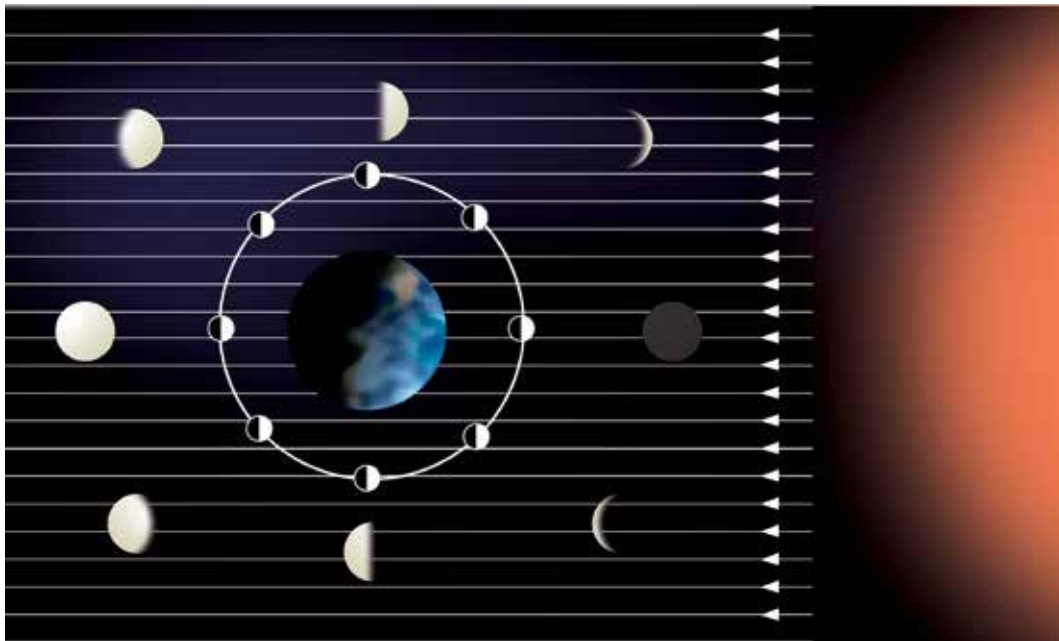

Figure 54.4. Positions of the moon in its orbit and its corresponding phases



WHAT DO WE CONCLUDE?

- From this activity we conclude that due to the revolution of the moon round the earth, the shape of its visible portion changes everyday.
- We see only that part of the moon, from which the light of the Sun is reflected towards us. This determines the visible portion of the moon.

- This is the cause of the moon's changing phase regularly.

! LET US ANSWER

1. Why do the phases of the moon occur?
2. In which part of the sky, eastern or western, will the new moon rise?
3. In which part of the sky, eastern or western, will the full moon rise?

(Note: For hints to answers to these questions, look at Fig. 54.4.)

? WHAT MORE CAN WE DO?

- Starting from the full moon day, observe the moon for several nights. Make the sketch of the moon every night in your notebook (Fig. 54.5). Compare your drawings with the phases of the moon as drawn in Fig. 54.4.
- Make a sketch of the relative positions of the Sun, moon and the earth on the day of the full moon and on the day of the new moon.



Figure 54.5

NOTE FOR THE TEACHER

- If a big ball is not available then you can ask the students to take a spherical pitcher and paint half of it white and half black.
- Encourage students to observe and compare the shape of moon on 7th and 22nd day, starting from new moon day.
- Ask them to make a sketch of the relative positions of the Sun, moon and the earth on these days.

THEME

7

NATURAL RESOURCES

ACTIVITY

55



WHAT WE HAVE TO DO?

Paste/draw pictures/figures of activities given in the boxes and write the role of air (if any) below each activity.



A

Burning



B

Girl is reading
a book

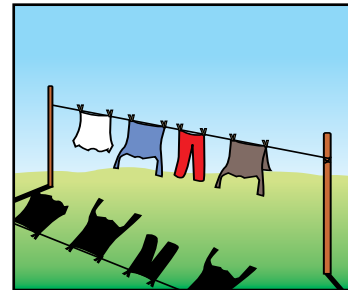

C

Clothes are drying
in an open field

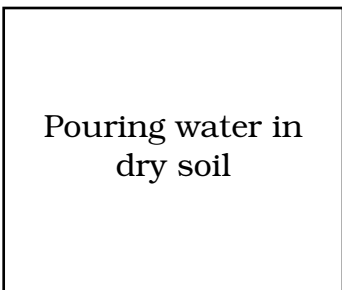

Pouring water in
dry soil

D

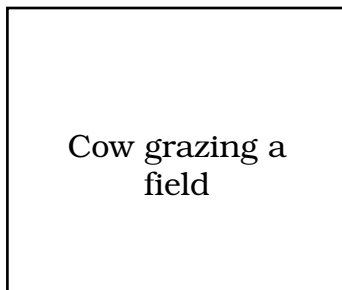

Cow grazing a
field

E



Flag fluttering

F

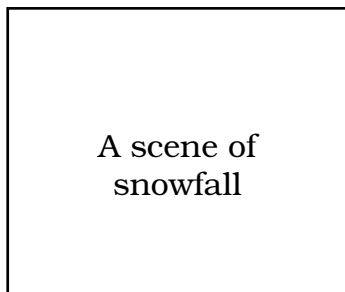

G

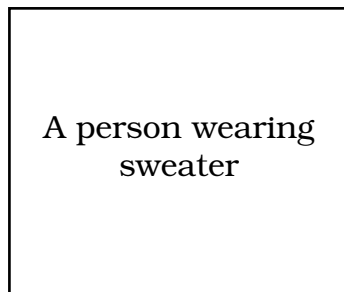

H



I

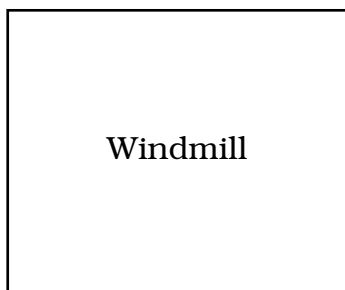

J

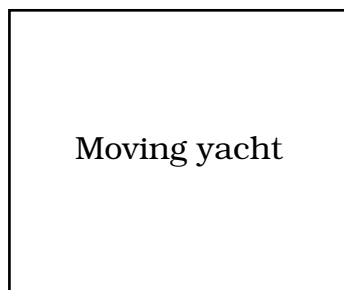

K



L

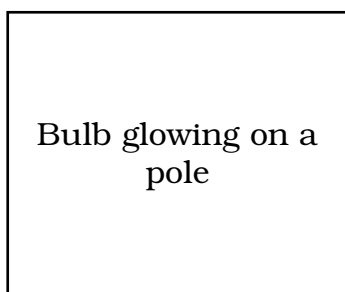

M

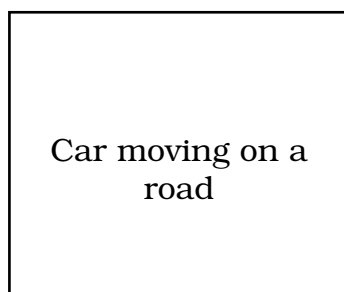

N

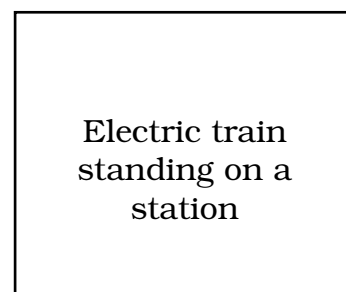

O



WHAT DO WE NEED?

Figures/pictures (from old newspapers, used magazine or you can draw), chart paper, glue, colours, a pair of scissors.



HOW DO WE PROCEED?

1. Collect pictures/figures from used newspapers, magazines or draw the figures yourself as shown in boxes A, B and C.
2. Cut them and paste them on a chart paper in a sequence shown in boxes above.
3. Write the role of air in each activity.



WHAT DO WE OBSERVE?

Activity	Role of air
A	Helps in combustion
B	Helps in breathing
C	Helps in drying clothes



WHAT DO WE CONCLUDE?

Air plays an important role in many of the activities in our life.



LET US ANSWER

1. How air helps in flying kite?
2. How does air help in drying clothes?
3. Name the components of air.
4. Which component of air is used in combustion?
5. Which component of air is present in maximum amount?



WHAT MORE CAN WE DO?

You can perform other activities such as-

- Air occupies space.
- Air is dissolved in water.
- Air is present in soil.

NOTE FOR THE TEACHER

- Teacher may plan a field trip to show places where air is polluted. These places can be industrial area, limekiln, brick kiln, cross road with red lights.
- The group may interview a traffic police man. Why often he/she wears a mask.

ACTIVITY 56**WHAT WE HAVE TO DO?**

Recycle waste paper.

**WHAT DO WE NEED?**

Collect waste paper from school or home, old newspapers, used notebooks, old magazines, etc, beaker, muslin cloth, frame with a wire mesh fitted into it, wooden block, sunmica sheet, a stone block of the size of wooden wire mesh frame, a mortar and pestle.

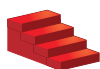
**HOW DO WE PROCEED?**

1. Tear the waste paper into small pieces. Put these pieces in a beaker and pour water just enough to soak the paper and keep it aside for one day (Fig. 56.1).
2. Next day drain the water and grind the soaked paper pieces with the help of mortar and pestle to get a smooth pulp (Fig. 56.2).
3. Spread the muslin cloth on the wire mesh.
4. Spread the wet pulp paste on the muslin cloth spread on wire mesh frame, to make a thin uniform layer (Fig. 56.3).
5. Put a sunmica sheet over the wet paste and place a block of stone over it so as to press the paste (Fig. 56.4).
6. Keep it aside for one day.
7. Next day carefully remove the block of stone and carefully separate the pulp sheet from the muslin cloth.
8. Spread the pulp sheet in open air under the sun or a fan to dry.



Figure 56.1
Beaker
containing
soaked
pieces of
paper



Figure 56.2
Grinding
soaked
pieces of
paper



Figure 56.3
Spreading
of wet pulp
paste on the
muslin cloth



Figure 56.4
Sunmica sheet
over wet paste
and block of
stone over it

9. Remove the dried sheet of paper.
10. Paper is ready to be used again (Fig. 56.5).



Figure 56.5
Recycled paper



WHAT DO WE OBSERVE?

Compare the texture, colour, etc of initial waste paper with one made by you.



WHAT DO WE CONCLUDE?

- Paper may be recycled.
- 'Reduce, Reuse, Recycle' should be our motto to save our environment and to Save Trees - The Precious Resource.



LET US ANSWER

1. Do you know any other waste material which can be reused?
2. Can you suggest some ways by which wastage of materials can be reduced?



WHAT MORE CAN WE DO?

- Make any piece of art, such as butterfly, dustbin, etc. using waste materials.
- Interview a *kabariwala* to find out what happens to the various materials he collects from homes and other places.

NOTE FOR THE TEACHER

- Suggest measures to show how the consumption of paper can be reduced.
- Teacher may also help students in making items from waste paper or hand made paper.

ACTIVITY 57**WHAT WE HAVE TO DO?**

Infiltration of water through soil.

**WHAT DO WE NEED?**

A used plastic bottle, soil, water, filter paper or a piece of cotton cloth, knife.

**HOW DO WE PROCEED?**

1. Take a clean used plastic bottle and cut it with a knife about 5 cm below the neck, The bottle is divided into two parts. The upper part will be used as a funnel and the lower part as a container (Fig. 57.1).
2. Fix a filter paper or cloth in the improvised funnel and keep it over the container. Now add some soil over the filter paper till it fills two third part of the funnel.
Your apparatus to show infiltration is ready (Fig 57.2).
3. Pour some water on the soil and wait for some time.

Do you find some water drops trickling down ?

If not, pour some more water on the soil surface till water starts trickling down (Fig. 57.3).



Figure 57.1
a) Improvised funnel
b) Improvised container



Figure 57.2
Set up for infiltration



Figure 57.3
Showing infiltration

**WHAT DO WE OBSERVE?**

The water which was poured over the soil has percolated through the soil and a part of it gets collected in the container.

Can you relate this activity with the accumulation of ground water?



WHAT DO WE CONCLUDE?

Surface water from any source (rain, pond, river, lake, spring, snow, human activities) percolate through soil and gets stored as ground water. This process is called infiltration.



LET US ANSWER

1. Do you think that you get same amount of water after infiltration? Justify your answer.
2. Do you know from where you get water in tube wells and hand pumps?
3. Water in a well is ground water. Justify the statement.
4. Do you think water is cleaned during infiltration? Explain.



WHAT MORE CAN WE DO?

Make a pit in the garden of a school or home. Connect the pit with the outlets of waste water. Cover the pit. Keep observing the pit time to time. Guess what happens to the water being collected in the pit?

This is your project to explore many more things.

NOTE FOR THE TEACHER

- While doing the activity teacher should see that students pour a measured quantity of water. Only then students can compare it with the quantity of water percolated in the container.
- While discussing 'Water - a Precious Resource' in the class, the concept of rain water harvesting can be highlighted on the basis of this activity.
- Encourage children to make a model of rain water harvesting as a group activity.

ACTIVITY 58**WHAT WE HAVE TO DO?**

Cleaning of muddy water.

**WHAT DO WE NEED?**

A sample of muddy water, containers, muslin cloth, alum, heating device.

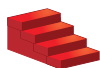
**HOW DO WE PROCEED?**

1. Take the sample of muddy water (Fig 58.1) and filter it using a piece of muslin cloth (Fig. 58.2).



Figure 58.1
Container containing muddy water



Figure 58.2
Filtration using muslin cloth

2. Take a piece of alum and tie it with a thread. Hold the thread and swirl the alum in water 2-3 times (Fig. 58.3).
3. This help in settling down the fine mud particles suspended in water, which could not be removed by filtration.
4. Leave the water undisturbed for some time.
5. Do you find any change in the transparency of water?
6. Now decant/filter the water using a clean piece of muslin cloth.



Figure 58.3
Swirling alum in water

7. Boil water for about 15-20 minutes to kill the germs.
8. Cool and filter the water again. This is your clean water.



WHAT DO WE OBSERVE?

- Suspended impurities of muddy water are separated by filtration.
- On leaving the water undisturbed after swirling with alum, the fine mud particles are settled down.



WHAT DO WE CONCLUDE?

Water can be cleaned with the help of simple processes such as filtration, treating with alum, boiling, etc.



LET US ANSWER

1. Can we use any material other than muslin cloth to filter the water?
2. Do you agree that boiling kills germs? Explain.
3. Do you think that the water purified in the above activity is fit for drinking? Justify your answer.



WHAT MORE CAN WE DO?

Arrange a field trip to the nearby water body to observe if it is being polluted. Note the observations and discuss in the class how pollution of the water body can be controlled.

NOTE FOR THE TEACHER

While discussing natural resources it is our moral duty to make students aware of three “Rs”

- R- Reduce
- R- Reuse
- R- Recycle

PROJECT WORK

Project work in science is usually an organised search, construction or task directed towards a specific purpose. Project work may involve a student or a small group of students. It provides an opportunity to the students to identify a problem, to design a work plan, to address the problem, to search for appropriate resources, to carry out their own plan and to draw conclusion on the basis of data/information collected. Projects help to stimulate interest in science, arouse curiosity, develop ability of independent critical thinking, and provide experience in using the tools and techniques besides relating science with daily life situations and development of self-confidence. In the process, the students learn fundamental principles of science, methods and processes of science, and are exposed to the phases involved in a scientific investigation. The activities related to the project may involve use of laboratory, library consultation, multimedia, internet, collection of information/data from the field or at home through surveys/interviews/collection of samples.

Students may choose a project depending on their enthusiasm, interest, availability of the material resources, and time available to furnish the project. As far as possible project work should be done during school hours, particularly at the upper primary stage. If the nature of the project is such that it has to be done outside the school hours, teachers should encourage the students to do it themselves. The teacher should exhort children to work by themselves without involving their parents on a given project and report the task honestly. At the same time the teacher should also appreciate the honest reporting without worrying too much about the perfection of the task assigned.

EXEMPLAR PROJECTS

PROJECT 1

GARBAGE IN GARBAGE OUT

Students may take up an interview based project. An interview with well framed questions may be used to gather information, data and then these may be analysed to draw some useful conclusions.



STEP 1 - WHAT DO WE WANT TO FIND OUT?

We produce so much waste everyday at school, e.g. papers, aluminium foils, barrels of pens and pencil shavings .Where is all this taken finally? Can we get something useful from the waste?

STEP 2 - WHAT WE HAVE TO DO?

You may become a “Save My Earth-Journalist”.The next time a junk/ scrap dealer- (*kabadwala*) comes to your house to collect household waste material. Interview him while selling the waste. Be respectful, offer him a glass of water and ask him if he would have the time to answer a few

of your questions. Inform him that you are pursuing a school project. An example questionnaire is provided.

STEP 3 - HOW TO GATHER DATA ?

Name :

Age :

Number of years spent in the trade:

What mode of transport does he uses to roam around your colony?

Where does he go and sell his products? Note down the address of the shop and ask for the location.

What all products does he accept from people apart from paper? Tick the appropriate and verify the money offered for each

- Metals- iron, copper, etc _____
- Plastic _____
- Old newspapers/magazines _____
- Cardboard _____
- Bottles – glass, plastic, metal _____
- Wood _____
- Electronic waste, used CD's, _____
computer wastes, etc. _____
- Others _____

Thank the scrap dealer for his time and try interview another scrap dealer. Compare your notes.

Make a list of, what you learnt from your interaction with the scrap dealer?

STEP 4 - WHAT DID WE FIND OUT?

Which materials are generally sold by the people to the scrap dealers?

Which materials are purchased by scrap dealers at higher cost?

STEP 5 - WHAT MORE CAN WE DO ?

Make a poster and generate awareness. You can design your own posters by being creative.

Do not throw away anything that can be recycled!

Here is a list of things you should always recycle (or reuse!).

To make your poster look good, you may add pictures of these things to be recycled.

Aluminium cans, Building materials, Cardboards, Chemicals, Electronic equipments, Glass (particularly bottles and jars), Magazines and Newspapers, Metals, Papers, Plastic Bags, Plastic Bottles, Tyres, Electrical appliances, Wood, Acid, batteries, etc.

STEP 6 - ASSESSMENT

Students will work in groups. Plan of action can be different for different groups. Some may use posters/pamphlets; some may like to have a street play on recycle and save earth.

Assessment may be done on groups involvement and presentation of their conclusion.

PROJECT 2**CAN WE HELP TO SAVE THE ENVIRONMENT?**

This is a small project which is meant to create awareness among children about the alarming situation of our environment. Environment has become a 'global dust bin', everyone talks and expresses concern about environmental degradation but none of us make even the slightest effort to reduce degradation and help conserve the natural environment. Through this project, an attempt has been made to convince the students that through individual and collective action we can contribute, in whatever, small way we can, to save the environment. This will also instill a 'feel good' feeling among children since they have acted for a worthy cause. Children can also learn from each other and can take a proactive role in the school by starting a "child brigade for environment".

HOW DO WE BEGIN?

This can be cast either as a group activity or as an individual task. Students will gather information from each other/teachers/other employees in the school/ elders/ parents/ siblings/ at home and fill in the Table 1

Table 1

S.No	Wastes generated in the school	Have I contributed to waste generation? (Y/N)	Wastes generated at home	Have I contributed to waste generation? (Y/N)
1				
2				
3				
4				
5				
6				
7				

Students will analyse certain features related to the wastes generated such as – In what state are they? How do they effect the environment? Are they bio-degradable? They will fill up the Table 2.

Table 2

S.No	Type of waste	Solid / Liquid / Gas	How does it affect the environment	Is it biodegradable?
1	Ball pen/refills	Solid	Land/Soil pollution	No
2				
3				
4				
5				

Next, students will categorise the wastes into those that can be recycled and those that can be reused by obtaining the required information from different sources and fill up the Table 3.

Table 3

S.No	Type of waste	Recyclable/Reusable
1	Lunch Box	Reusable and recyclable
2		
3		
4		
5		

WHAT AFTER?

From the above list, one item is selected which is non-biodegradable. Students will explore through various sources/ways (teachers/internet/environmental groups) by which reuse/recycling can be done. They will prepare posters through which they will communicate to others the information they have collected. At the end, they will also take a pledge that, in future, they will minimise the use of non-biodegradable materials. Whenever they use such materials, they will ensure its safe disposal or their availability for reuse/recycling purpose.

PROJECT 3**WE CAN FACE THE WORLD**

Visually challenged persons can read, write and can do many more things very successfully. Do you know Helen Keller?

Helen A.Keller, an American author and lecturer is perhaps the most well known and inspiring visually challenged person.

She was born in 1880 as a healthy baby girl in a small town in Alabam.

Just when she was 18 months old she suffered with high fever for few days and lost her sight and hearing power.

It was very disappointing for her and for her family, but a teacher, Miss Sullivan helped young Helen to learn about the world around her.

Because of her determination, courage and hard work, Helen was able to complete her graduation from a university.

Helen wrote a number of books including



Helen A. Keller

“The Story of my Life (1903)”

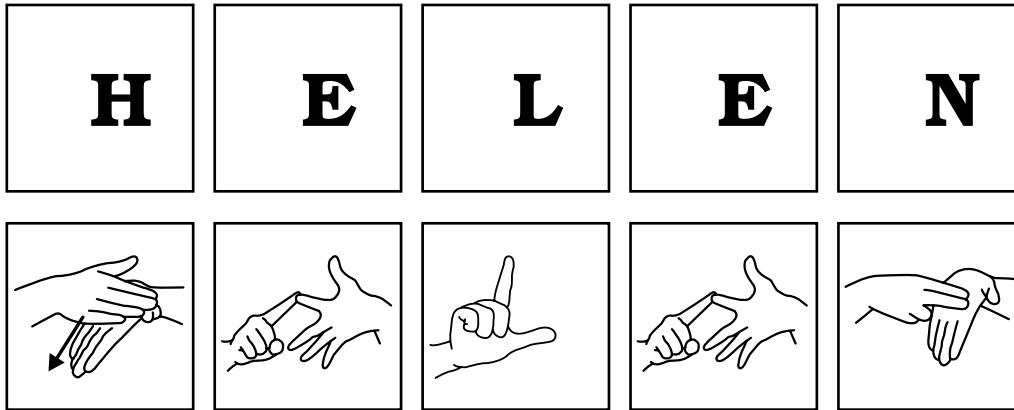

Do you know some persons in our country visually challenged and have been excelled in any field. Find out at least any one of them – His / Her struggles and achievements

Do you know some children with special needs? Write about them how they handle things and face the world

Teacher may discuss about Braille in the class

EXEMPLAR EDUCATIONAL GAMES

EDUCATIONAL GAME 1

FUN WITH DANCING BALLS



WHAT DO WE NEED?

Beaker, naphthalene balls, vinegar or dilute hydrochloric acid, sodium hydrogencarbonate

- Fill two third of a beaker with vinegar or dilute solution of hydrochloric acid, and put 5-6 small naphthalene balls in it.
- Add about half a spoon of sodium hydrogencarbonate (baking soda) to it and observe.
- You will find that naphthalene balls start moving to the surface of the solution and then again go down. When they stop going up and down, again add more baking soda.
- You may give some colour to this solution by adding few drops of extract from beet root or any other flower.



Baking soda reacts with vinegar or hydrochloric acid to form carbon dioxide gas. The bubbles of carbon dioxide stick to the naphthalene balls and bring them upwards. The balls again go down when the gas bubbles leave the surface of balls and the process goes on till the gas is liberated.

EDUCATIONAL GAME 2

LET US COMPLETE THE FLOW CHART BY FILLING EMPTY BOXES

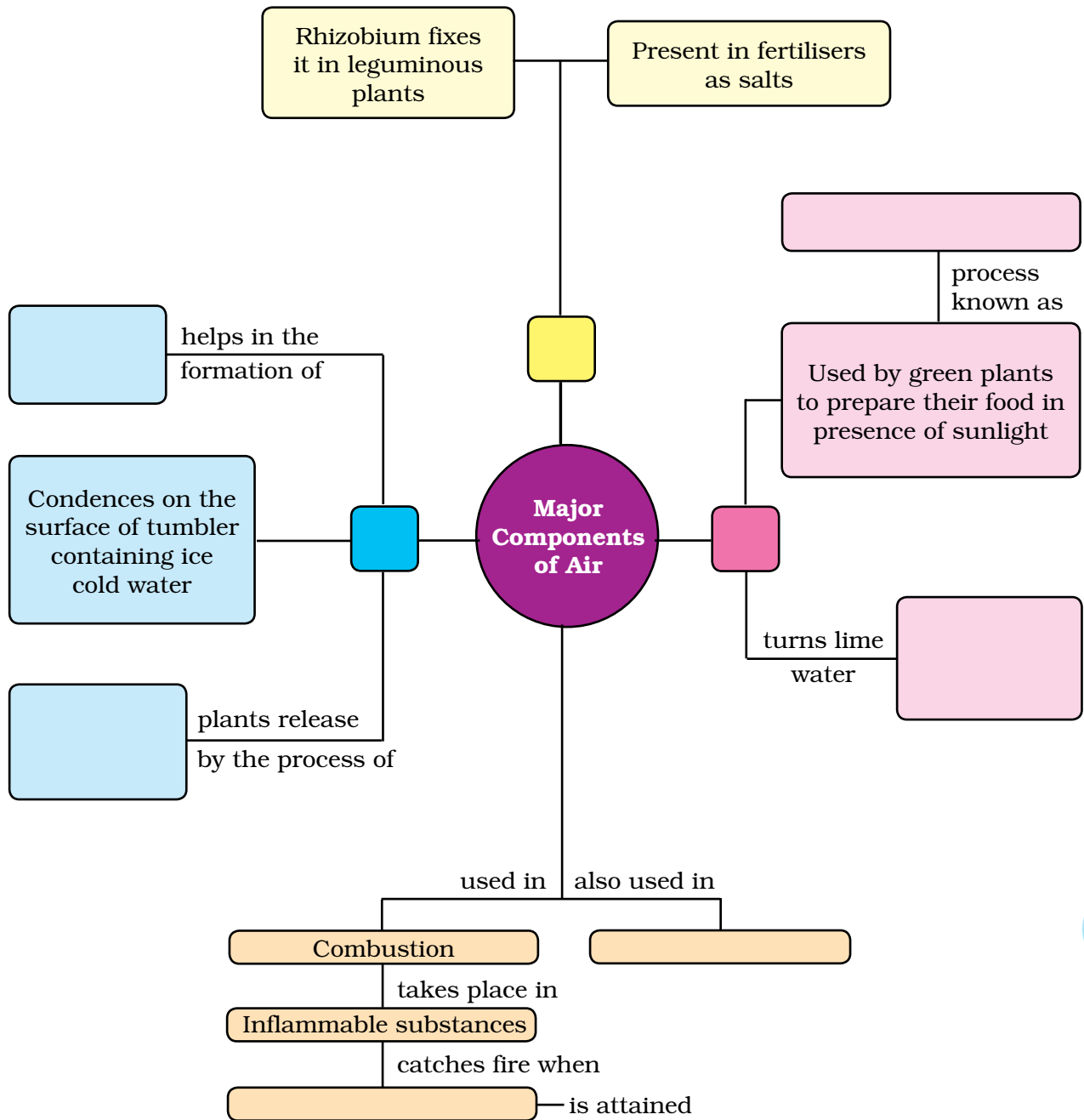

EDUCATIONAL GAME 3

BEAWARE!

- Look at these pictures carefully and find out if there is anything undesirable.
- Write your comments to make the things desirable.



A. Throwing garbage in a water body



B. Burning waste paper



C. Washing bicycle with running water



D. Loud music in a party



E. Using same needle for more than one patient



F. Working in a group

Discuss your comments/ideas in your class.

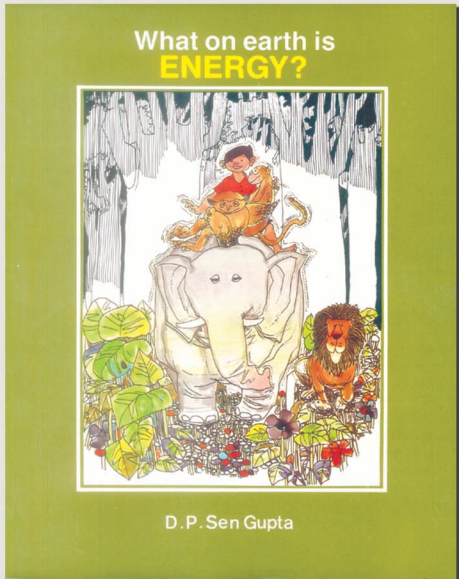

What on earth is ENERGY?

D.P. Sen Gupta

Rs. 40.00 / Paperback / 90pp/

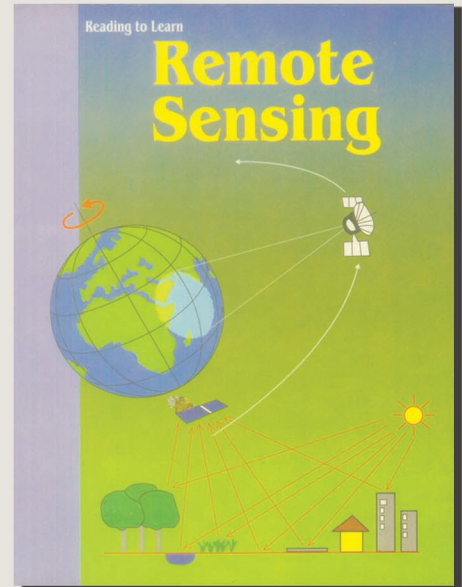

Remote Sensing

Meenakshi Kumar

Rs. 53.00 / Paperback / 74 pp

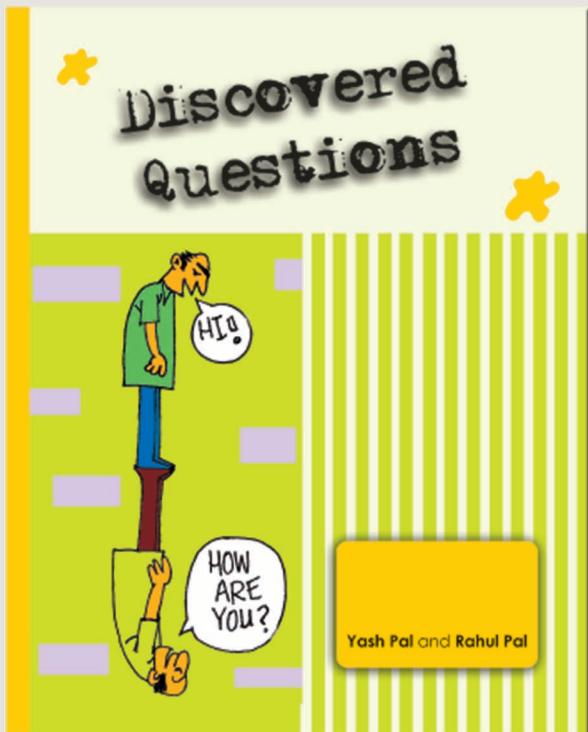

Discovered Questions

Yash Pal and Rahul Pal

Rs. 65.00 / Paperback / 142 pp

For further enquiries, please visit www.ncert.nic.in or contact the Business Managers at the addresses of the regional centres given on the copyright page.

